

## IK1512

The IK1512 camera is a highly sensitive infrared camera (SWIR, NIR). The sensitivity interval reaches from 900 nm to 1700 nm. A sophisticated, thermal optimized housing allows sensor operation without active cooling. The optional available M42 to C-mount adapter extends the number of lenses which can be used with this camera. Via standard USB2.0 interface can be controlled by each PC or notebook. The 14-bit A/D converter provides high dynamics of captured image data. Correction procedures specially adapted to properties of InGaAs sensors assure very high image quality.

### Sensor Properties

- InGaAs
- 320 × 256 pixel
- 30 μm × 30 μm pixel size
- percentage of good pixels > 99,5 %
- quantum efficiency > 70 %
- progressive scan
- global shutter

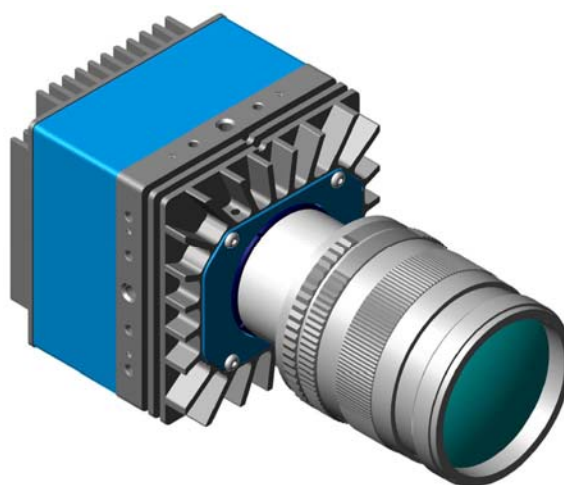

### Application Examples

- laser beam profiling
- NIR (SWIR) – image processing
- spatially resolved NIR spectroscopy
- imaging improvement, (undercover) surveillance
- quality insurance in semiconductor industry, e.g. solar cell inspection
- scientific applications (medicine [e.g. OCT], biology, astronomy)
- material analysis (plastics, textiles, glass, metal, wood)
- industrial thermal image processing for temperatures > 200°C
- process surveillance
- 2D humidity analysis, water detection
- biometry (artificial hair appears black and natural hair white)
- analysis of paintings (art history, falsification detection)

### Spectral Sensor Sensitivity

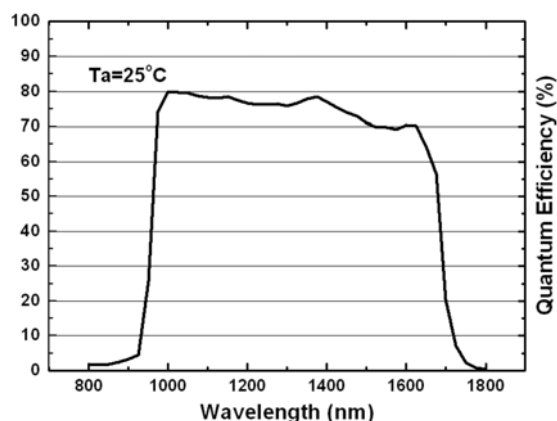

## Technical Specifications

Sensor	InGaAs matrix sensor
Resolution	320 (H) × 256 (V)
Pixel size	30 × 30 μm <sup>2</sup>
Spectral range	0.9 μm – 1.7 μm
Active Sensor size	9.6 mm (H) × 7.68mm (V)
A/D resolution	14 bit
Frame rate	100 fps
Exposure time	10 μs - 5 s
Gain	Two modes (low gain and high gain) Gain factor: 21
Digital interface	USB2.0 (HighSpeed)
Trigger	opto-decoupled
Power supply	12-24 V (DC)
Power loss	< 5 W
Temperature range (operational)	0 °C - + 55 °C
Temperature range (storage)	- 40 °C - + 55 °C
Housing	anodized aluminum with integrated cooling fins
Dimensions without lens	73.5 × 91 × 91 mm <sup>3</sup>
Weight (without lens)	ca. 1300 g
Lens mount	M42 or C – Mount; adjustable

### Frontal View

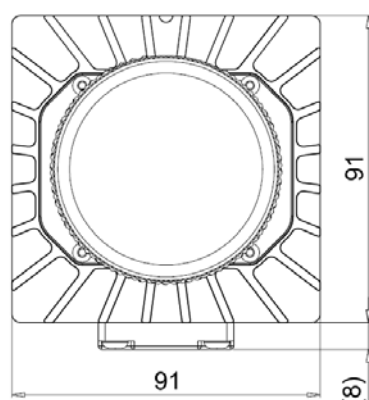

### Lateral View

