

DPA Digital Current Controller

(DPA1024E will be discontinued in October 2019 and replaced with DPA2024E)

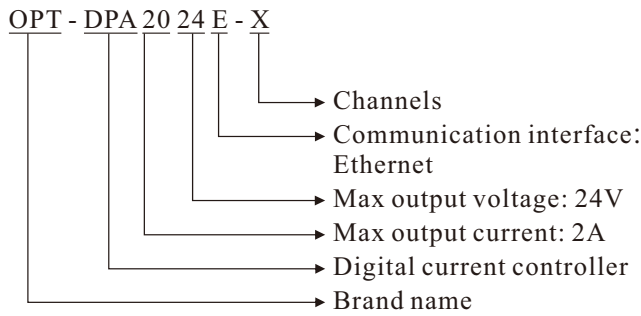

Selection Guide



Model	Channels	Compatible LED Light
OPT-DPA1024E-4	4	10mA~1A 24V light
OPT-DPA2024E-4		10mA~2A 24V light
OPT-DPA1024E-8	8	10mA~1A 24V light
OPT-DPA2024E-8		10mA~2A 24V light
OPT-DPA1024E-16	16	10mA~1A 24V light
OPT-DPA2024E-16		10mA~2A 24V light

Product Features

- 1 Programmable trigger mode available, 32 steps at max; the trigger source, intensity and trigger pulse width of each step can be set
- 2 Autosense of rated current for LED light
- 3 Trigger response time $\leq 15 \mu s$
- 4 Max trigger frequency up to 20KHz
- 5 Simultaneous communication of multiple channels available
- 6 Manual setting for max output current
- 7 256 light intensity levels
- 8 Trigger signal input: connect an external signal source (e.g. a camera trigger signal) to strobe the LED light, and extend life span of light
- 9 Support RS232 communication
- 10 Support 100M Ethernet communication

- 11 Temperature controlled fan, longer life span
- 12 Withstanding high voltage (AC1500V 1min, leak current $< 10mA$)
- 13 High insulation resistance (DC500V $> 20M\Omega$)
- 14 Easy to install: screw and DIN rail mounting available.

Device Overview

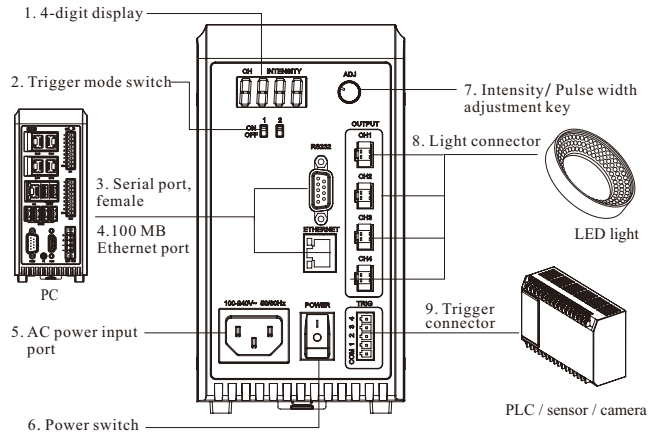

No.	Item	Description
1	4-digit display	1st number indicates the channel, other 3 numbers show the value
2	Trigger mode switch	To change the trigger mode
3	Serial port, female	RS232 communication interface with the PC
4	100 MB Ethernet port	Ethernet communication interface with the PC
5	AC power input	100 - 240 V AC, 50/60 Hz
6	Power switch	To turn the controller on/off
7	Intensity/ pulse width adjustment key	To adjust intensity or trigger pulse width. Press it, the chosen channel number twinkle on digit display; press it again will chose next channel. Rotate it in clockwise, the value increased; rotate it in anti-clockwise, the value decreased
8	Light connector	In total, four lights can be controlled individually
9	Trigger connector	For connection with an external trigger source

Trigger Mode Setting

Mode	Trigger mode switch 1	Trigger mode switch 2
Continuous on	ON	ON
Autosense for current once	ON	OFF
Normal trigger mode	OFF	ON
High power trigger mode	OFF	OFF

Parameters

Model	DPA1024E	DPA2024E	Descriptions
Voltage input	AC100~240V		50/60Hz
Lighting mode	Continuous on / Strobe		Set via trigger mode switch or DEMO software
Auto sense of rated current	for 10mA-1A 24V LED light	for 10mA-2A 24V LED light	Autosense of rated current for LED light available via the DEMO software
Manual set for max output current	10mA - 1A	10mA - 2A	Choose manual set via DEMO software
Intensity control	256 levels		Set via adjustment key or DEMO software
Short circuit protection	Yes		The related channel shuts down and "ER2" appears on the display

Model	DPA1024E	DPA2024E	Descriptions
Over current protection	Yes		Once the current over 10% of set value the related channel shuts down and "ER1" appears on the display
Normal trigger	256 intensity levels		
High intensity trigger	1A output for single channel	2A output for single channel	
Unit of time	1ms	1 μ s/10 μ s 1ms/100ms	Set via DEMO software
Normal trigger pulse width	1ms~999ms	1 μ s~30s	Set via adjustment key or DEMO software
High intensity trigger pulse width	0.01~5.00ms		Set via adjustment key or DEMO software
Programmable trigger mode	No	Yes	Intensity, trigger pulse width, trigger source of each step can be set
Response time	\leq 80 μ s	\leq 15 μ s	
Trigger response frequency	4KHz	20KHz	
Control of fan	constant voltage/temperature		
Power output	24W/CH	48W/CH	4/8CH total output \leq 48W; 16CH total output \leq 180W
Communication	RS232 / Ethernet		
Standby power consumption	4CH: 8W	4CH: 9.6W	Input: 220V
	8CH: 9.2W	8CH: 11.8W	
	16CH: 13.7W	16CH: 16.1W	
Hi-Pot test	AC1500V 1Min		Leak current <10mA
Insulation resistance	DC500V		>20M Ω
Working temperature	-5 $^{\circ}$ C~50 $^{\circ}$ C		
Dimension (L×W×H)	4CH	91x132x171mm	
	8CH	108x132.5x172.1mm	
	16CH	140x132.5x172.1mm	
Weight (kg)	4CH	1	1.1
	8CH	1.3	1.2
	16CH	1.7	1.6

ERR Code Description

Code	ERR Reason	Display	Solution
Er0	No LED light connected	"Er0" on digit display	Connect LED light
Er1	Over current protection	"Er1" on digit display	Remove ERR and reboot
Er2	Short circuit protection	"Er2" on digit display	Remove ERR and reboot
Er3	Over voltage protection	"Er3" on digit display	Remove ERR and reboot
Er4	Hardware communication ERR	"Er4" on digit display	Return to OPT for repair
Er5	Hardware communication ERR	"Er5" on digit display	Return to OPT for repair

Remark: "----" appears on the digit display during controller startup. And value will appear after startup finished

Trigger

DPA2024 has three kind trigger modes: normal trigger, high intensity trigger, programmable trigger;
Four kind trigger polarities: rising edge trigger, falling edge trigger, real time positive trigger, real time negative trigger.
Default set is rising edge trigger

Trigger Mode	Trigger Polarity	Compatible Controller
Normal trigger	Rising edge trigger	DPA2024E DPA1024E
	Real time positive trigger	
	Real time negative trigger	
	Falling edge trigger	
High intensity trigger	Rising edge trigger	DPA2024E DPA1024E
	Real time positive trigger	
	Real time negative trigger	
	Real anegative trigger	
Programmable trigger	Rising edge trigger	DPA2024E
	Falling edge trigger	

Trigger Sequence Chart

Rising edge trigger

Illuminating time is equal to the set trigger pulse width.
Trigger pulse width set via DEMO or adjustment key.
Refer to Chart 1.1

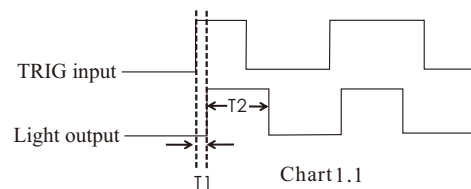

Falling edge trigger

Illuminating time is equal to the set trigger pulse width.
Trigger pulse width set via DEMO or adjustment key.
Refer to Chart 1.2

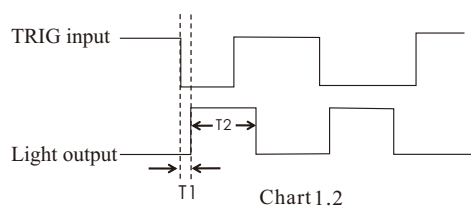

Real time positive trigger

When the trigger signal is high level, illuminating time is equal to pulse width of high level. Refer to Chart 1.3

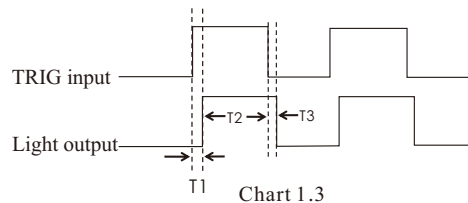

Real time negative trigger

When trigger signal is low level voltage, illuminating time is equal to low level pulse width. Refer to Chart 1.4

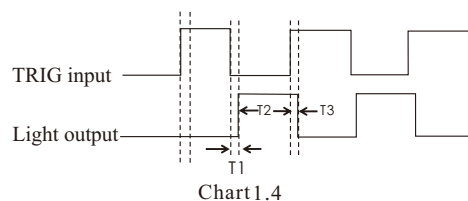

Remarks:

- (1) T1: OFF to ON time; T2: Trigger pulse width; T3: ON to OFF time
- (2) Normal trigger: DPA1024E $T1 \leq 80\mu s$, $T3 \leq 10\mu s$, T2 can set 1ms~999ms; DPA2024E $T1 \leq 15\mu s$, $T3 \leq 10\mu s$, T2 can set 1 μs ~30s;
- (3) High intensity trigger: DPA1024E $T1 \leq 80\mu s$, $T3 \leq 10\mu s$, T2 can set 0.01-5.00ms; DPA2024E $T1 \leq 15\mu s$, $T3 \leq 10\mu s$, T2 can set 0.01-5.00ms.

Trigger Wiring Diagram

4 trigger channels. "COM" is the common interface. Two -way optocoupler is inside. Input 0-2V is low level. Input 5-24V is high level. Default set is rising edge trigger. Wiring diagram as below

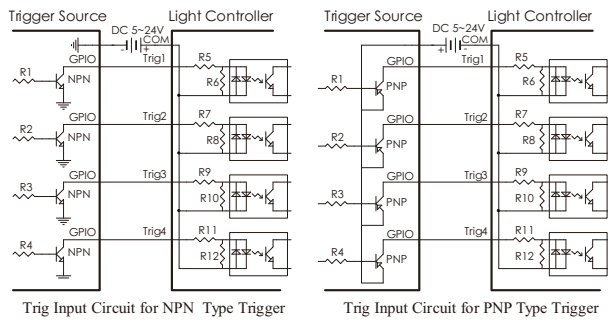

Dimensional Drawings [mm]

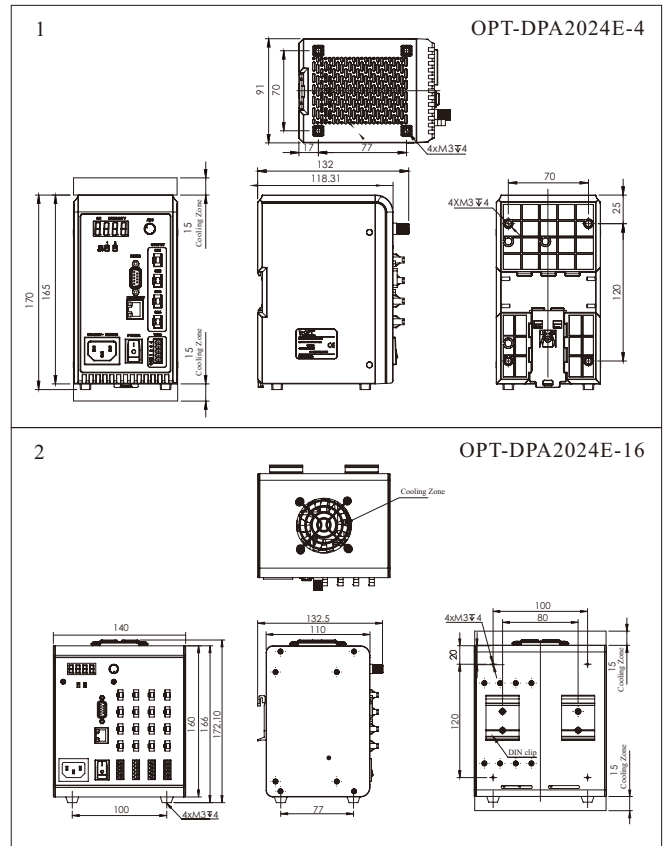

EHD imaging GmbH
 Zum Rennplatz 15
 D-49401 Damme
 Tel: +49-5491-2090
 email: info@ehdimaging.de
 web: www.ehd.de