

2024

EHD SC-ITR Series Cooled Cameras Manual



1.1 SC-ITR Series TE-Cooling USB3.0 CMOS Camera

1.1.1 The Basic Characteristic of the SC-ITR Series

SC-ITR series camera adopts SONY Exmor CMOS and GPIXEL GSENSE and GLUX sCMOS sensor as the image-picking device and USB3.0 is used as the transfer interface to increase the frame rate.

With the two-stage peltier cooling sensor chip to 40 degree below ambient temperature. This will greatly increase the signal to noise ratio and decrease the image noise. Smart structure is designed to assure the heat radiation efficiency and avoid the moisture problem. Electric fan is used to increase the heat radiation speed.

SC-ITR series comes with advanced video & image processing application EHDView / EHDLite; Providing Windows/Linux/OSX multiple platform SDK; Native C/C++, C#/VB.NET, DirectShow, Twain Control API;

The SC-ITR can be widely used in low light environment and microscope fluorescence image capture and analysis, as well as the astronomy deep sky application.



SC-ITR Series (Square Housing)

The basic characteristic of SC-ITR series can be summarized as follows:

- Standard camera with SONY Exmor CMOS and GPIXEL GSENSE sensors;
- 8 Bit /12 Bit or 16 Bit switchable (depends on sensor)
- TE-cooling with controllable electric fan;
- Sensor chip cooling up to 40°C below ambient temperature;
- Working temperature can be regulated to specified temperature in 5 minutes;
- Smart structure to assure the heat radiation efficiency and avoid the moisture problem;
- IR-CUT/AR coated windows (Optional);
- C-Mount
- USB3.0 5Gbit/second interface ensuring high speed data transmission;
- Up to 3600 seconds long time exposure;
- Ultra-Fine color engine with perfect color reproduction capability;
- Support the capture of video and image in software / hardware trigger mode
- With advanced video & image processing application EHDView/EHDLite;
- Support both video and trigger modes;
- Providing Windows/Linux/Mac OS multiple platforms SDK;
- Native C/C++, C#/VB.NET, DirectShow, Twain control API;

1.3 SC-ITR Series Camera Specifications(23)

1.3.1 SC-ITR Series USB3 Camera (17)

Model Number	Image Sensor	Pixel Size(μm)	G Sensitivity Dark Signal	FPS/Resolution Bit depth	Binning	Exposure Time
SC492M-ITR ITRM145000A	45M/IMX492(M,RS) 1.4"(18.93x13.00)	2.315x2.315	175mV with 1/30s 0.03mV with 1/30s	8.1@8176x5616 30.0@4080x2808 8.1@7408x5556 33.0@3696x2778 10.4@8176x4320 34.7@4096x2160 62.5@2048x1080 86.5@1360x720 8 Bit / 12 Bit	1x1(3:2) 2x2(3:2) 1x1(4:3) 2x2(4:3) 1x1(17:9) 2x2(17:9) 3x3(17:9) 4x4(17:9)	100us~15s
SC571C-ITR ITRP126000A	26M/IMX571(C, RS) 1.8"(23.48x15.67) APS-C	3.76x3.76	485mv with 1/30s 0.07mv with 1/30s	14@6224x4168 37@3104x2084 110@2064x1386 8 Bit / 16 Bit	1x1 2x2 3x3	150us~15s
SC571M-ITR ITRM126000A	26M/IMX571(M, RS) 1.8 "(23.48x15.67) APS-C	3.76x3.76	871mv with 1/30s 0.07mv with 1/30s	14@6224x4168 37@3104x2084 110@2064x1386 8 Bit / 16 Bit	1x1 2x2 3x3	150us~15s
SC269C-ITR ITRP121000A	21M/IMX269(C) 4/3"(17.4x13.1)	3.3x3.3	400mv with 1/30s 0.1mv with 1/30s	17@5280x3954 17@3952x3952 56@2640x1976 67@1760x1316 192@584x438 8 Bit / 12 Bit	1x1 1x1 2x2 3x3 9x9	100us~15s
SC183C-ITR ITRP120000A	20M/IMX183(C,RS) 1 "(13.056x8.755)	2.4x2.4	462mv with 1/30s 0.21mv with 1/30s	19.0@5440x3648 48.8@2736x1824 59.4@1824x1216 8 Bit / 12 Bit	1x1 2x2 3x3	53us~15s
SC183M-ITR ITRM120000A	20M/IMX183(M,RS) 1 "(13.056x8.755)	2.4x2.4	777mv with 1/30s 0.21mv with 1/30s (F8.0)	19.0@5440x3648 48.8@2736x1824 59.4@1824x1216 8 Bit / 12 Bit	1x1 2x2 3x3	53us~15s
SC294C-ITR ITRP110300A	10.3M/IMX294(C,RS) 4/3 "(9.56x6.5)	2.315x2.315	419mv with 1/30s 0.12mv with 1/30s	30.0@4128x2808 38.5 @4096x2160 59.8@2048x1080 87.2@1360x720 8 Bit / 14 Bit	1x1 1x1 2x2 3x3	150us~15s
SC492M-ITR ITRM110300A	10.3M/IMX492(M,RS) 1.4 "(9.56x6.5)	2.315x2.315	175mv with 1/30s 0.12mv with 1/30s	30.0@4128*2808 38.5@4096*2160 59.8@2048*1080 87.2@1360*720 8 Bit / 14 Bit	1x1 1x1 2x2 3x3	150us~15s
SC533C-ITR ITRP109000A	9M/IMX533(C,RS) 1"(11.28x11.28)	3.76x3.76	534mv with 1/30s 0.04mv with 1/30s	40@2992x3000 62@1488x1500 186@992x998 8 Bit / 14 Bit	1x1 2x2 3x3	100us~15s
SC533M-ITR ITRM109000A	9M/IMX533(M,RS) 1"(11.28x11.28)	3.76x3.76	877mv with 1/30s 0.04mv with 1/30s	40@2992x3000 62@1488x1500 186@992x998 8 Bit / 14 Bit	1x1 2x2 3x3	100us~15s
SC585C-ITR ITRP108300A	8.3M/IMX585(C,RS) 1/1.2"(11.14x6.26)	2.9x2.9	5970mv with 1/30s 0.13mv with 1/30s	45@3840x2160 70@1920x1080 8 Bit / 12 Bit	1x1 2x2	30us~15s
SC428C-ITR ITRP107100A	7.0M/IMX428(C,GS) 1.1 "(14.4x9.9)	4.5x4.5	2058mv with 1/30s 0.15mv with 1/30s	51.3@3200x2200 133.8@1584x1100 8 Bit / 12 Bit	1x1 1x1	6us~15s
SC428M-ITR ITRM107100A	7.0M/IMX428(M,GS) 1.1 "(14.4x9.9)	4.5x4.5	3354mv with 1/30s 0.15mv with 1/30s	51.3@3200x2200 133.8@1584x1100 8 Bit / 12 Bit	1x1 1x1	6us~15s
SC432C-ITR ITRP101700A	1.7M/IMX432(C,GS) 1.1 "(14.4x9.9)	9.0x9.0	4910mv with 1/30s 0.3mv with 1/30s	98.6@1600x1100 8 Bit / 12 Bit	1x1	6us~15s
SC432M-ITR ITRM101700A	1.7M/IMX432(M,GS) 1.1 "(14.4x9.9)	9.0x9.0	8100mv with 1/30s 0.3mv with 1/30s	98.6@1600x1100 8 Bit / 12 Bit	1x1	6us~15s
SC9701UV-ITR ITRM101300A	1.3M/GLUX9701BSI (M,UV,RS) 1 "(12.493x9.994)	9.76x9.76	2.57x10 ⁸ (e- /(W/m ² ,s)) QE89%@610nm 0.08(e-/s/pix) @-	30fps@1280×1024 30fps@640×512 8 Bit / HDR 16 Bit	1x1 2x2	63us~60s

			28C			
SC1605UV-ITR ITRM100500A	0.5M/GLUX1605BSI (M,UV,RS) 1“(12.8x9.6)	16.0x16.0	6.4x10 ⁸ e- /((W/m ²).s) QE95%@560nm 50(e-/s/pix)	60.0@800x600 60.0@400x300 8 Bit / HDR 16 Bit	1x1 2x2	27us~60s

*C: Color; M: Mono; UV: Ultraviolet; RS: Rolling shutter; GS: Global shutter.

1.3.2 SC-ITR Series GigE Camera (6)

Model Number	Image Sensor	Pixel Size(μm)	G Sensitivity Dark Signal	FPS/Resolution Bit depth	Binning	Exposure Time
SC183M-ITR-G	20M/IMX183(M,RS) 1“(13.056x8.755)	2.4x2.4	777mv with 1/30s 0.21mv with 1/30s	4.5@5440x3648 18.5@2736x1824 41.7@1824x1216 8 Bit / 12 Bit	1x1 2x2 3x3	53us~15s
SC183C-ITR-G	20M/IMX183(C,RS) 1“(13.056x8.755)	2.4x2.4	462mv with 1/30s 0.21mv with 1/30s	4.5@5440x3648 18.5@2736x1824 41.7@1824x1216 8 Bit / 12 Bit	1x1 2x2 3x3	53us~15s
SC428M-ITR-G	7.0M/IMX428(M,GS) 1.1“(14.4x9.9)	4.5x4.5	3354mv with 1/30s 0.15mv with 1/30s	16.4fps@3200×2200 66fps@1600×1100 8 Bit / 12 Bit	1x1 1x1	6us~15s
SC428C-ITR-G	7.0M/IMX428(C,GS) 1.1“(14.4x9.9)	4.5x4.5	2058mv with 1/30s 0.15mv with 1/30s	16.4fps@3200×2200 66fps@1600×1100 8 Bit / 12 Bit	1x1 1x1	6us~15s
SC432M-ITR-G	1.7M/IMX432(M,GS) 1.1“(14.4x9.9)	9.0x9.0	8100mv with 1/30s 0.3mv with 1/30s	66fps@1600×1100 8 Bit / 12 Bit	1x1	6us~15s
ISC432C-ITR-G	1.7M/IMX432(C,GS) 1.1“(14.4x9.9)	9.0x9.0	4910mv with 1/30s 0.3mv with 1/30s	66fps@1600×1100 8 Bit / 12 Bit	1x1	6us~15s

*C: Color; M: Mono; RS: Rolling shutter; GS: Global shutter; G: 1 Gigabit Ethernet port.

3 SC-ITR Series Camera Specification (22)

3.1 SC492M-ITR

Table 3-1 SC492M-ITR camera specifications

Model	ITR3CMOS4500KMA
Parameter	45M pixels 1.4" CMOS USB3.0 industrial camera
Camera	
Sensor model	Sony IMX492LLJ-C
Pixel size	2.315 μm x 2.315μm
Sensor size	1.4"
Frame rate	8.1@8176x5616 30.0@4080x2808 8.1@7408x5556 33.0@3696x2778 10.4@8176x4320 34.7@4096x2160 62.5@2048x1080 86.5@1360x720
Readout Noise	2.67e-(HCG) 2.74e-(LCG)
Full Well	14796.69e-(HCG) 14859.92e-(LCG)
Dynamic range	72dB (HCG) 72dB (LCG)
SNRmax	41.7dB(HCG) 41.72dB(LCG)
Sensitivity	175mV
Dark current	0.03mV
Gain range	1x-50x
Exposure time	100μs-15sec
Shutter	Rolling shutter
Binning	Software2x2, 3x3, 4x4, hardware2x2, 3x3, 4x4
Data interface	USB3.0 (USB3.1 GEN1)
Digital I/O	One optical-coupling isolated input, one optical-coupling isolated output, two non-isolated input and output
Data Format	8bit / 12bit
General specification	
Power supply	Power with USB3.0 or 12V Power adapter
Power consumption	24.12w
Temperature	Working temperature -10~50℃, storage temperature -30~70℃
Humidity	20%-80%, no condensation
Size	80mm x 80mm x 102mm
Weight	860g
Lens mount	C mount
Software	EHDView/ SDK
Platform and architecture	Win32/WinRT/Linux/macOS/Android; X86/X64/armhf/armel/arm64
Certification	CE, FCC

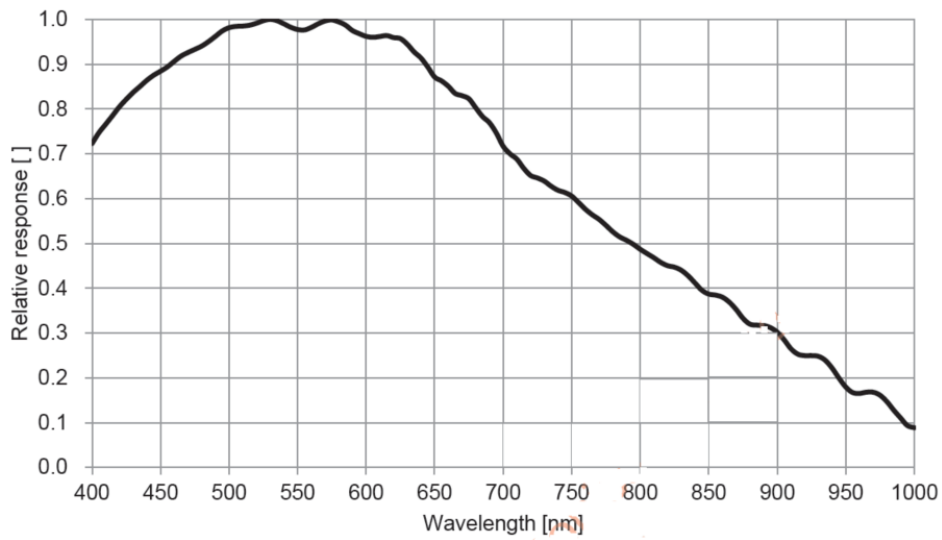

Figure 3-1 SC492M-ITR spectral response curve

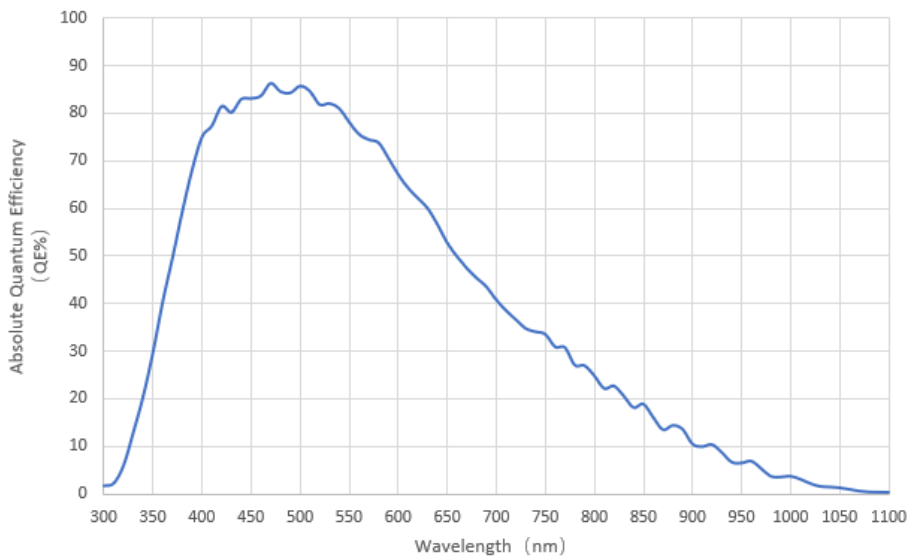

Figure 3-2 SC492M-ITR spectral absolute quantum efficiency

3.2 SC571C-ITR

Table 3-2 SC571C-ITR camera specifications

Model	ITR3CMOS26000KPA
Parameter	26M pixels 1.8" CMOS USB3.0 industrial camera
Camera	
Sensor model	Sony IMX571BQR-C
Pixel size	3.76 μm x 3.76 μm
Sensor size	1.8"
Frame rate	14fps@6224x4168 37fps@3104x2084 110fps@2064x1388
Readout Noise	1.31e-(HCG) 3.15e-(LCG)
Full Well	16569.55e-(HCG) 51591.91e-(LCG)
Dynamic range	81.78dB (HCG) 84dB (LCG)
SNRmax	42.19dB(HCG) 47.13dB(LCG)
Sensitivity	485mv
Dark current	0.07mv
Gain range	1x-50x
Exposure time	100 μs -15sec
Shutter	Rolling shutter
Binning	Software2x2, 3x3, 4x4, hardware2x2, 3x3, 4x4
Data interface	USB3.0 (USB3.1 GEN1)
Digital I/O	One optical-coupling isolated input, one optical-coupling isolated output, two non-isolated input and output
Data Format	8bit / 16bit
General specification	
Power supply	Power with USB3.0 or 12V Power adapter
Power consumption	28.32w
Temperature	Working temperature -10~50 $^{\circ}\text{C}$, storage temperature -30~70 $^{\circ}\text{C}$
Humidity	20%-80%, no condensation
Size	80mm x 80mm x 101.5mm
Weight	860g
Lens mount	C mount
Software	EHDView/ SDK
Platform and architecture	Win32/WinRT/Linux/macOS/Android; X86/X64/armhf/armel/arm64
Certification	CE, FCC

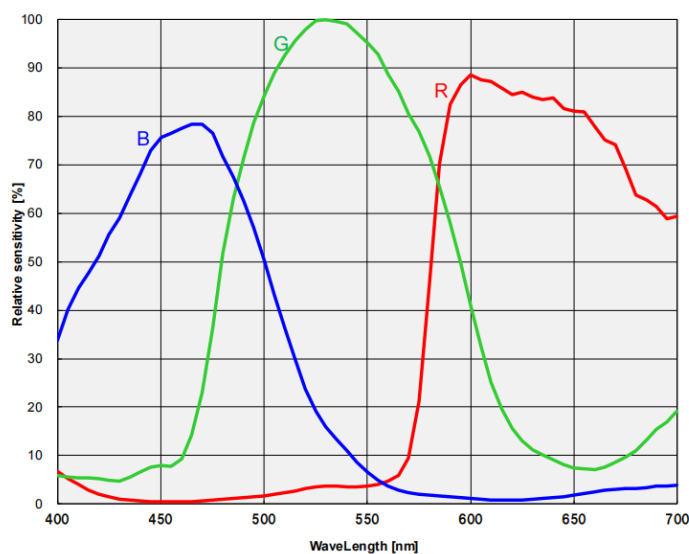

Figure 3-3 SC571C-ITR spectral response curve

3.3 SC571M-ITR

Table 3-3 SC571M-ITR camera specifications

Model	ITR3CMOS26000KMA
Parameter	26M pixels 1.8" CMOS USB3.0 industrial camera
Camera	
Sensor model	Sony IMX571BLR-J
Pixel size	3.76 μm x 3.76 μm
Sensor size	1.8"
Frame rate	14fps@6224x4168 37fps@3104x2084 110fps@2064x1388
Readout Noise	0.94e-(HCG) 2.23e-(LCG)
Full Well	16770.94e-(HCG) 51081.55e-(LCG)
Dynamic range	84.72dB (HCG) 86.88dB (LCG)
SNRmax	42.25dB(HCG) 47.08dB(LCG)
Sensitivity	871mv
Dark current	0.07mv
Gain range	1x-50x
Exposure time	100 μs -15sec
Shutter	Rolling shutter
Binning	Software2x2, 3x3, 4x4, hardware2x2, 3x3, 4x4
Data interface	USB3.0 (USB3.1 GEN1)
Digital I/O	One optical-coupling isolated input, one optical-coupling isolated output, two non-isolated input and output
Data Format	8bit / 16bit
General specification	
Power supply	Power with USB3.0 or 12V Power adapter
Power consumption	25.08w
Temperature	Working temperature -10~50 $^{\circ}\text{C}$, storage temperature -30~70 $^{\circ}\text{C}$
Humidity	20%-80%, no condensation
Size	80mm x 80mm x 101.5mm
Weight	860g
Lens mount	C mount
Software	EHDView/ SDK
Platform and architecture	Win32/WinRT/Linux/macOS/Android; X86/X64/armhf/armel/arm64
Certification	CE, FCC

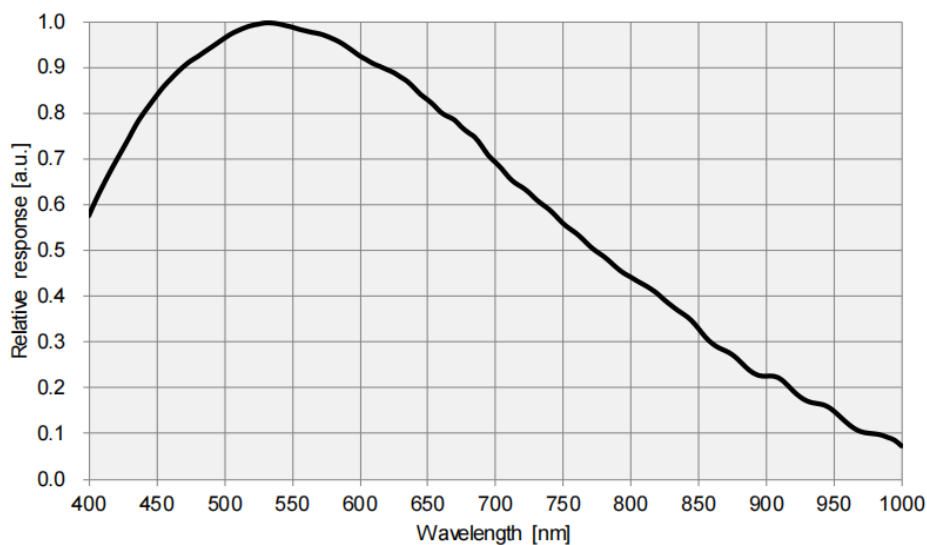

Figure 3-4 SC571M-ITR spectral response curve

3.4 SC571C-ITR

Table 3-4 SC571C-ITR camera specifications

Model	ITR3CMOS21000KPA
Parameter	21M pixels 4/3" CMOS USB3.0 industrial camera
Camera	
Sensor model	Sony IMX269AQR
Pixel size	3.3 μm x 3.3 μm
Sensor size	4/3"
Frame rate	17@5280x3954 17@3952x3952 56@2640x1976 67@1760x1316 192@584x438
Readout Noise	0.91e-(HCG) 0.61e-(LCG)
Full Well	11356.85e-(HCG) 23015.4e-(LCG)
Dynamic range	72dB (HCG) 72dB (LCG)
SNRmax	40.55dB(HCG) 43.62dB(LCG)
Sensitivity	400mv
Dark current	0.1mv
Gain range	1x-50x
Exposure time	100 μs -15sec
Shutter	Rolling shutter
Binning	Software2x2, 3x3, hardware2x2, 3x3, 4x4
Data interface	USB3.0 (USB3.1 GEN1)
Digital I/O	One optical-coupling isolated input, one optical-coupling isolated output, two non-isolated input and output
Data Format	8bit / 12bit
General specification	
Power supply	Power with USB3.0 or 12V Power adapter
Power consumption	Cooled 24.4W / Uncooled 5.81W
Temperature	Working temperature -10~50 $^{\circ}\text{C}$, storage temperature -30~70 $^{\circ}\text{C}$
Humidity	20%-80%, no condensation
Size	80mm x 80mm x 101.5mm
Weight	860g
Lens mount	C mount
Software	EHDView/ SDK
Platform and architecture	Win32/WinRT/Linux/macOS/Android; X86/X64/armhf/armel/arm64
Certification	CE, FCC

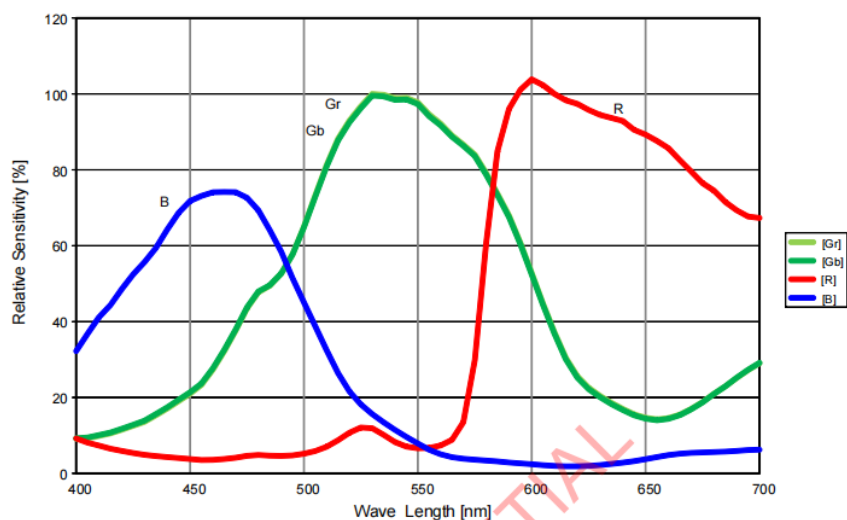

Figure 3-5 SC571C-ITR spectral response curve

3.5 SC183C-ITR

Table 3-5 SC183C-ITR camera specifications

Model Parameter	ITR3CMOS20000KPA	ITR3CMOS20000KPA-G
	20M pixels 1" CMOS USB3.0 / GigE industrial camera	
Camera		
Data interface	USB3.0	GigE
Sensor model	Sony IMX183CQK	
Pixel size	2.4 μm x 2.4 μm	
Sensor size	1"	
Frame rate	19.0fps@5440 x 3684 48.8fps@2736 x 1824 59.4fps@1824 x 1216	4.5fps@5440 x 3684 18.5fps@2736 x 1824 41.7fps@1824 x 1216
Readout Noise	3.38e-	
Full Well	15929.69e-	
Dynamic range	72dB	
SNRmax	42.02dB	
Sensitivity	462mV	
Dark current	0.21mV	
Gain range	1x-50x	
Exposure time	53 μs -15sec	
Shutter	Rolling shutter	
Binning	Software2x2, 3x3, hardware2x2, 3x3, 4x4	
Digital I/O	One optical-coupling isolated input, one optical-coupling isolated output, two non-isolated input and output	
Data Format	8bit / 12bit	
General specification		
Power supply	Power with USB3.0 or 12V Power adapter	12V Power adapter
Power consumption	14.64W	TBD
Temperature	Working temperature -10~50 $^{\circ}\text{C}$, storage temperature -30~70 $^{\circ}\text{C}$	
Humidity	20%-80%, no condensation	
Size	80mm x 80mm x 101.5mm	
Weight	860g	
Lens mount	C mount	
Software	EHDView/ SDK	
Platform and architecture	Win32/WinRT/Linux/macOS/Android; X86/X64/armhf/armel/arm64	
Certification	CE, FCC	

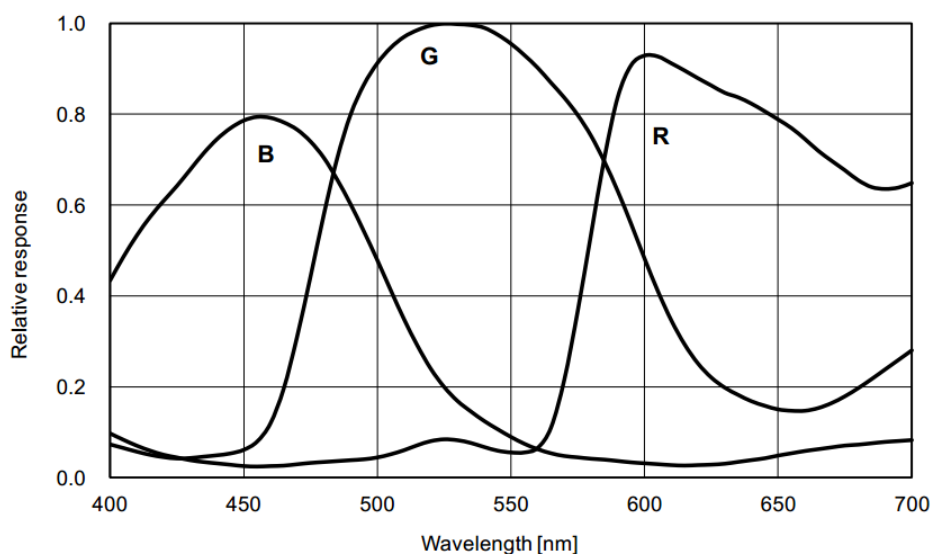

Figure 3-6 SC183C-ITR spectral response curve

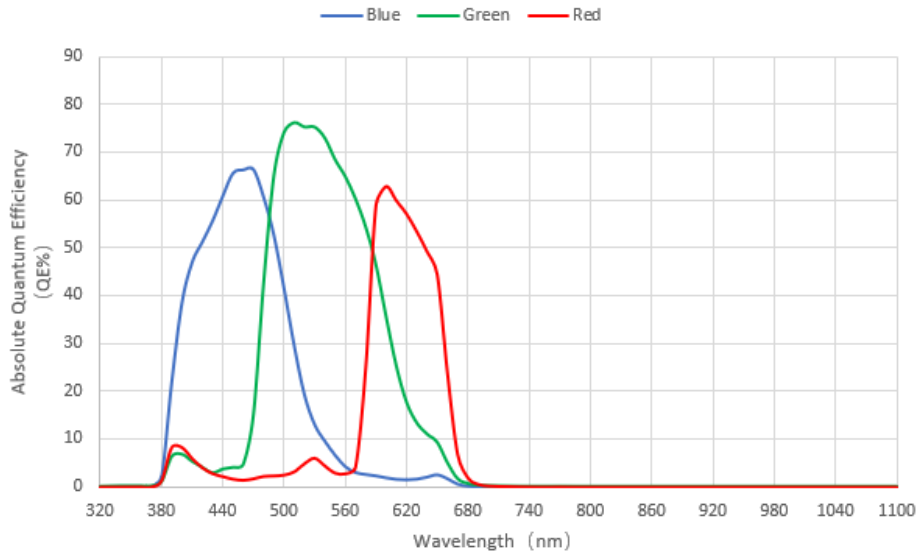

Figure 3-7 SC183C-ITR spectral absolute quantum efficiency

3.6 SC183M-ITR

Table 3-6 ISC183M-ITR camera specifications

Model Parameter	ITR3CMOS2000KMA	ITR3CMOS2000KMA -G
	20M pixels 1" CMOS USB3.0 / GigE industrial camera	
Camera		
Data interface	USB3.0	GigE
Sensor model	Sony IMX183CQK	
Pixel size	2.4 μm x 2.4 μm	
Sensor size	1"	
Frame rate	19.0fps@5440 x 3684 48.8fps@2736 x 1824 59.4fps@1824 x 1216	4.5fps@5440 x 3684 18.5fps@2736 x 1824 41.7fps@1824 x 1216
Readout Noise	3.38e-	
Full Well	15929.69e-	
Dynamic range	72dB	
SNRmax	42.02dB	
Sensitivity	462mV	
Dark current	0.21mV	
Gain range	1x-50x	
Exposure time	53 μs -15sec	
Shutter	Rolling shutter	
Binning	Software2x2, 3x3, hardware2x2, 3x3, 4x4	
Digital I/O	One optical-coupling isolated input, one optical-coupling isolated output, two non-isolated input and output	
Data Format	8bit / 12bit	
General specification		
Power supply	Power with USB3.0 or 12V Power adapter	12V Power adapter
Power consumption	14.64W	TBD
Temperature	Working temperature -10~50 $^{\circ}\text{C}$, storage temperature -30~70 $^{\circ}\text{C}$	
Humidity	20%-80%, no condensation	
Size	80mm x 80mm x 101.5mm	
Weight	860g	
Lens mount	C mount	
Software	EHDView/ SDK	
Platform and architecture	Win32/WinRT/Linux/macOS/Android; X86/X64/armhf/armel/arm64	
Certification	CE, FCC	

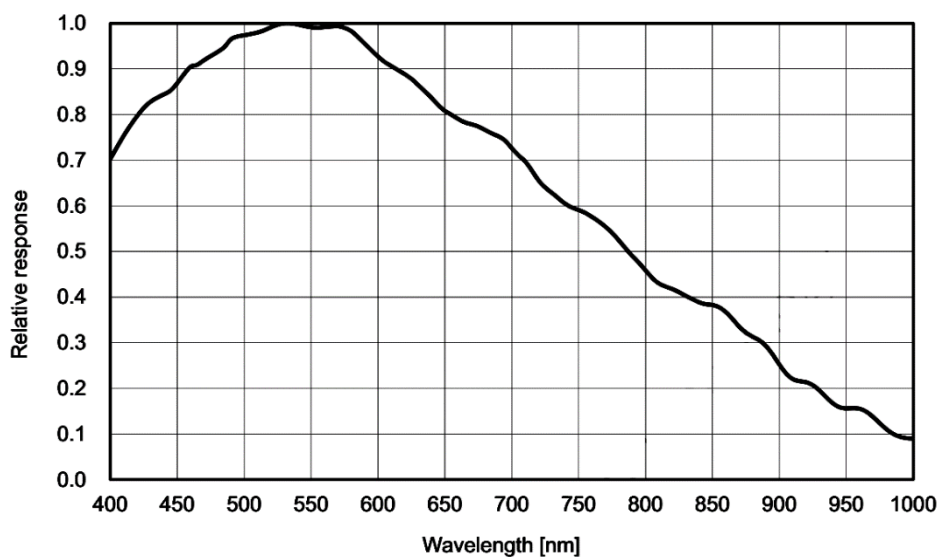

Figure 3-8 SC183M-ITR spectral response curve

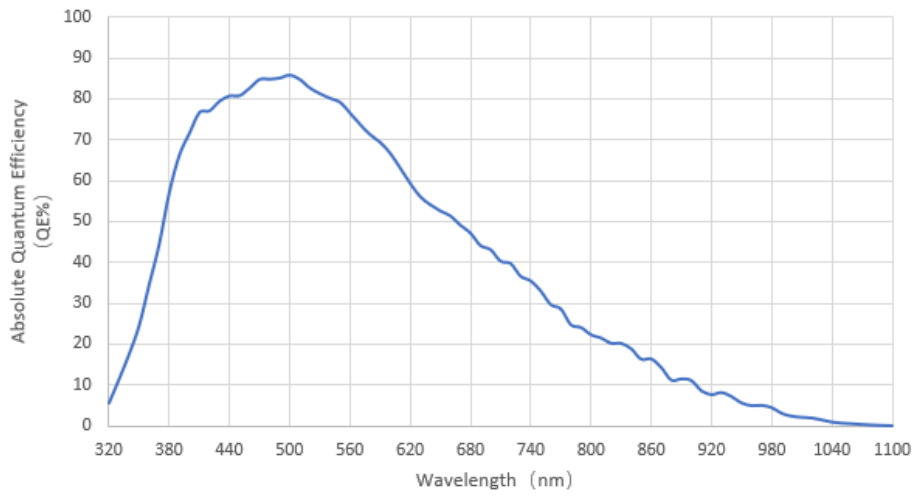

Figure 3-9 SC183M-ITR spectral absolute quantum efficiency

3.7 SC294C-ITR

Table 3-7 SC294C-ITR camera specifications

Model	ITR3CMOS10300KPA
Parameter	10.3M pixels 1.4" CMOS USB3.0 industrial camera
Camera	
Sensor model	Sony IMX294CJK
Pixel size	2.315 μm x 2.315 μm
Sensor size	4/3"
Frame rate	30.0@4128x2808 38.5 @4096x2160 59.8@2048x1080 87.2@1360x720
Readout Noise	0.26e-(HCG) 2.51e-(LCG)
Full Well	15017.21e-(HCG) 64919.86e-(LCG)
Dynamic range	84dB (HCG) 84dB (LCG)
SNRmax	41.77dB(HCG) 48.12dB(LCG)
Sensitivity	419mv
Dark current	0.12mV
Gain range	1x-50x
Exposure time	150 μs -15sec
Shutter	Rolling shutter
Binning	Software2x2, 3x3, hardware2x2, 3x3, 4x4
Data interface	USB3.0 (USB3.1 GEN1)
Digital I/O	One optical-coupling isolated input, one optical-coupling isolated output, two non-isolated input and output
Data Format	8bit / 14bit
General specification	
Power supply	Power with USB3.0 or 12V Power adapter
Power consumption	Cooled 30.9W / Uncooled 11.82W
Temperature	Working temperature -10~50°C, storage temperature -30~70°C
Humidity	20%-80%, no condensation
Size	80mm x 80mm x 102mm
Weight	860g
Lens mount	C mount
Software	EHDView/ SDK
Platform and architecture	Win32/WinRT/Linux/macOS/Android; X86/X64/armhf/armel/arm64
Certification	CE, FCC

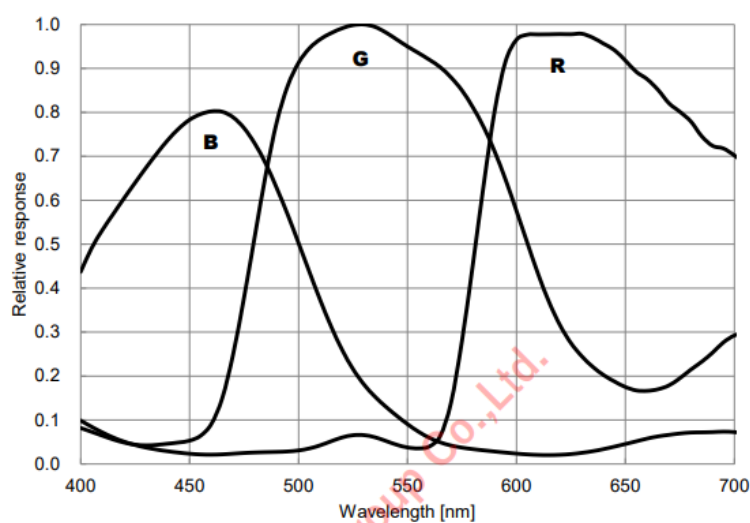

Figure 3-10 SC294C-ITR spectral response curve

3.8 SC492M-ITR

Table 3-8 SC492M-ITR camera specifications

Model	ITR3CMOS10300KMA
Parameter	10.3M pixels 1.4" CMOS USB3.0 industrial camera
Camera	
Sensor model	Sony IMX492LLJ-C
Pixel size	2.315 μm x 2.315 μm
Sensor size	1.4"
Frame rate	30.0@4128x2808 38.5 @4096x2160 59.8@2048x1080 87.2@1360x720
Readout Noise	0.26e-(HCG) 2.51e-(LCG)
Full Well	15017.21e-(HCG) 64919.86e-(LCG)
Dynamic range	84dB (HCG) 84dB (LCG)
SNRmax	41.77dB(HCG) 48.12dB(LCG)
Sensitivity	175mv
Dark current	0.03mV
Gain range	1x-50x
Exposure time	150 μs -15sec
Shutter	Rolling shutter
Binning	Software2x2, 3x3, hardware2x2, 3x3, 4x4
Data interface	USB3.0 (USB3.1 GEN1)
Digital I/O	One optical-coupling isolated input, one optical-coupling isolated output, two non-isolated input and output
Data Format	8bit / 14bit
General specification	
Power supply	Power with USB3.0 or 12V Power adapter
Power consumption	Cooled 30.9W / Uncooled 11.82W
Temperature	Working temperature -10~50 $^{\circ}\text{C}$, storage temperature -30~70 $^{\circ}\text{C}$
Humidity	20%-80%, no condensation
Size	80mm x 80mm x 102mm
Weight	860g
Lens mount	C mount
Software	EHDView/ SDK
Platform and architecture	Win32/WinRT/Linux/macOS/Android; X86/X64/armhf/armel/arm64
Certification	CE, FCC

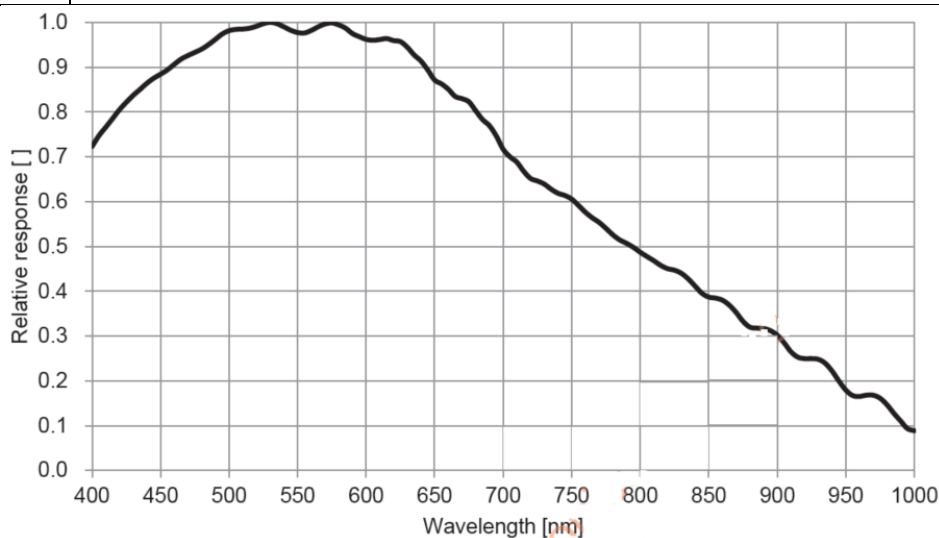

Figure 3-11 SC492M-ITR spectral response curve

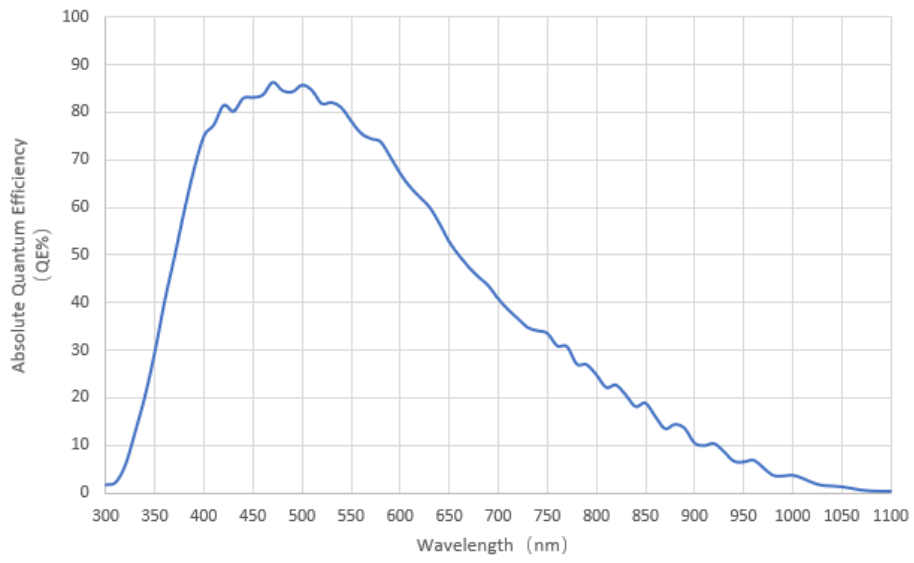

Figure 3-12 SC492M-ITR spectral absolute quantum efficiency

3.9 ISC533C-ITR

Table 3-9 SC533C-ITR camera specifications

Model	ITR3CMOS09000KPA
Parameter	9M pixels 1" CMOS USB3.0 industrial camera
Camera	
Sensor model	Sony IMX533CQK-C
Pixel size	3.76 μm x 3.76 μm
Sensor size	1"
Frame rate	40@2992x3000 62@1488x1500 186@992x998
Readout Noise	1.47e-(HCG) 3.8e-(LCG)
Full Well	16745.76e-(HCG) 51073.49e -(LCG)
Dynamic range	81.12dB (HCG) 82.56dB (LCG)
SNRmax	42.24dB(HCG) 47.08dB(LCG)
Sensitivity	534mv
Dark current	0.04mV
Gain range	1x-50x
Exposure time	100 μs -15sec
Shutter	Rolling shutter
Binning	Software2x2, 3x3, hardware2x2, 3x3, 4x4
Data interface	USB3.0 (USB3.1 GEN1)
Digital I/O	One optical-coupling isolated input, one optical-coupling isolated output, two non-isolated input and output
Data Format	8bit / 14bit
General specification	
Power supply	Power with USB3.0 or 12V Power adapter
Power consumption	Cooled 22.37W / Uncooled 7.27W
Temperature	Working temperature -10~50 $^{\circ}\text{C}$, storage temperature -30~70 $^{\circ}\text{C}$
Humidity	20%-80%, no condensation
Size	80mm x 80mm x 101.5mm
Weight	860g
Lens mount	C mount
Software	EHDView/ SDK
Platform and architecture	Win32/WinRT/Linux/macOS/Android; X86/X64/armhf/armel/arm64
Certification	CE, FCC

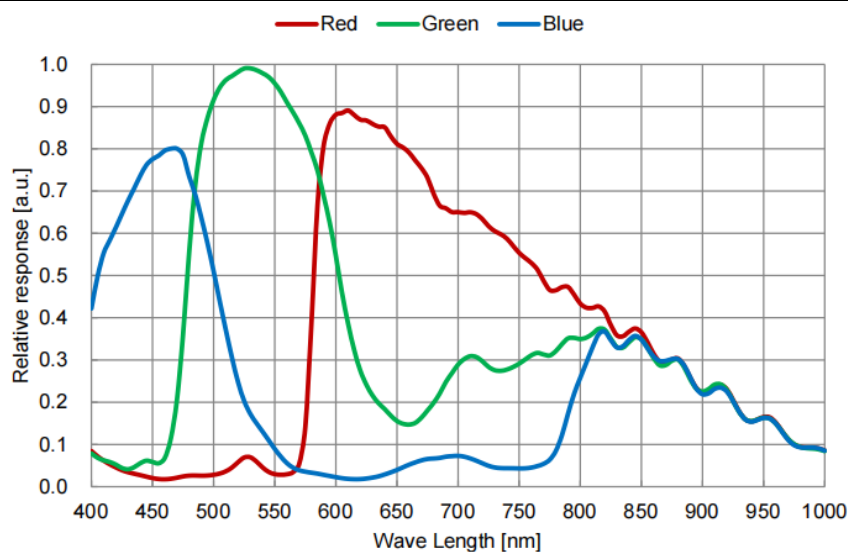

Figure 3-13 SC533C-ITR spectral response curve

3.10 SC533M-ITR

Table 3-10 SC533M-ITR camera specifications

Model	ITR3CMOS09000KMA
Parameter	9M pixels 1" CMOS USB3.0 industrial camera
Camera	
Sensor model	Sony IMX533CLK-D
Pixel size	3.76 μm x 3.76 μm
Sensor size	1"
Frame rate	40@2992x3000 62@1488x1500 186@992x998
Readout Noise	1.47e-(HCG) 3.8e-(LCG)
Full Well	16745.76e-(HCG) 51073.49e -(LCG)
Dynamic range	81.12dB (HCG) 82.56dB (LCG)
SNRmax	42.24dB(HCG) 47.08dB(LCG)
Sensitivity	877mv
Dark current	0.04mV
Gain range	1x-50x
Exposure time	100 μs -15sec
Shutter	Rolling shutter
Binning	Software2x2, 3x3, hardware2x2, 3x3, 4x4
Data interface	USB3.0 (USB3.1 GEN1)
Digital I/O	One optical-coupling isolated input, one optical-coupling isolated output, two non-isolated input and output
Data Format	8bit / 14bit
General specification	
Power supply	Power with USB3.0 or 12V Power adapter
Power consumption	Cooled 22.37W / Uncooled 7.27W
Temperature	Working temperature -10~50 $^{\circ}\text{C}$, storage temperature -30~70 $^{\circ}\text{C}$
Humidity	20%-80%, no condensation
Size	80mm x 80mm x 101.5mm
Weight	860g
Lens mount	C mount
Software	EHDView/ SDK
Platform and architecture	Win32/WinRT/Linux/macOS/Android; X86/X64/armhf/armel/arm64
Certification	CE, FCC

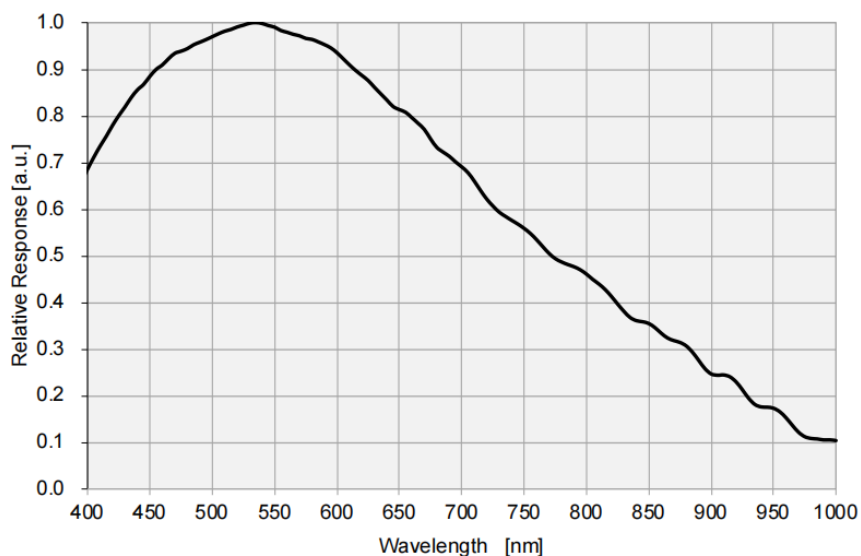

Figure 3-14 SC533M-ITR spectral response curve

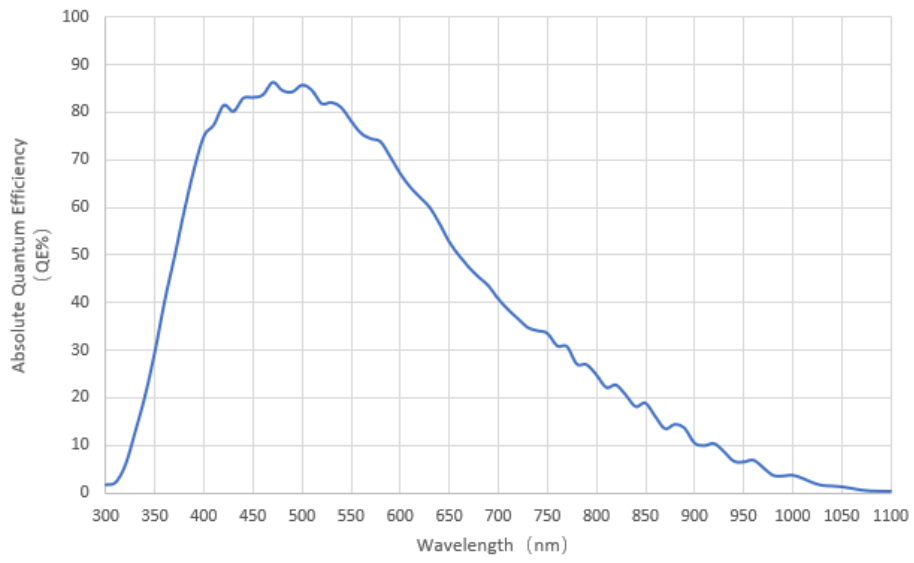

Figure 3-15 SC533M-ITR spectral absolute quantum efficiency

3.11 SC585C-ITR

Table 3-11 SC585C-ITR camera specifications

Model	ITR3CMOS08300KPA
Parameter	8.3M pixels 1/1.2" CMOS USB3.0 industrial camera
Camera	
Sensor model	Sony IMX585-AAQJ1-C
Pixel size	2.9 μm x 2.9 μm
Sensor size	1/1.2"
Frame rate	45fps@3840 x 2160 70fps@1920 x 1080
Readout Noise	2.81e-(LCG) 0.42e-(HCG)
Full Well	40029.57e-(LCG) 4152.75e-(HCG)
Dynamic range	72dB (LCG) 72dB (HCG)
SNRmax	46.02dB(LCG) 36.18dB(HCG)
Sensitivity	5970mV
Dark current	0.13mV
Gain range	1x-50x
Exposure time	30 μs -15sec
Shutter	Rolling shutter
Binning	Software2x2, 3x3
Data interface	USB3.0 (USB3.1 GEN1)
Digital I/O	One optical-coupling isolated input, one optical-coupling isolated output, two non-isolated input and output
Data Format	8bit / 12bit
General specification	
Power supply	Power with USB3.0 or 12V Power adapter
Power consumption	Cooled 26.88W / Uncooled 10.26W
Temperature	Working temperature -10~50 $^{\circ}\text{C}$, storage temperature -30~70 $^{\circ}\text{C}$
Humidity	20%-80%, no condensation
Size	80mm x 80mm x 101.5mm
Weight	860g
Lens mount	C mount
Software	EHDView/ SDK
Platform and architecture	Win32/WinRT/Linux/macOS/Android; X86/X64/armhf/armel/arm64
Certification	CE, FCC

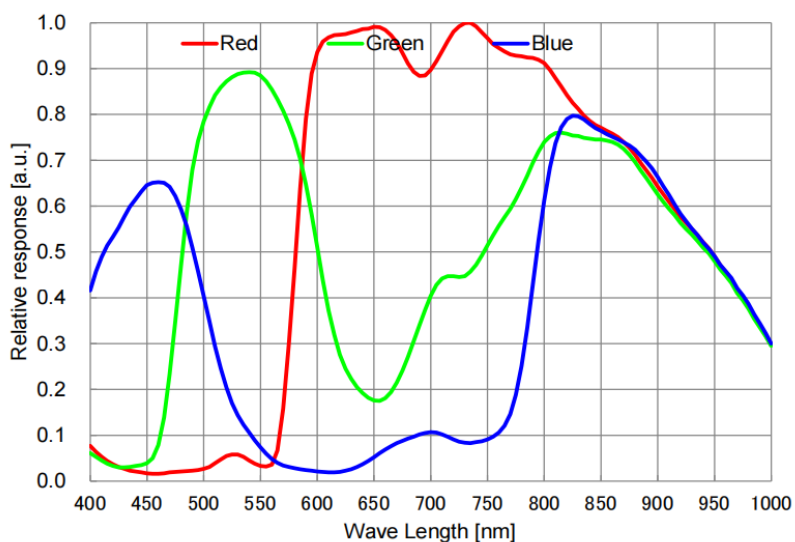

Figure 3-16 SC585C-ITR spectral response curve

3.12 SC428C-ITR

Table 3-12 SC428C-ITRA camera specifications

Model Parameter	ITR3CMOS07100KPA	ITR3CMOS07100KPA-G
	7.1M pixels 1.1" CMOS USB3.0 / GigE industrial camera	
	Camera	
Data interface	USB3.0	GigE
Sensor model	Sony IMX428LQJ	
Pixel size	4.5 μm x 4.5 μm	
Sensor size	1.1"	
Frame rate	51.4fps@3200 x 2200 133.8fps@1584 x 1100	16.4fps@3200 x 2200 66fps@1584 x 1100
Readout Noise	2.38e-	
Full Well	11154.09e-	
Dynamic range	72dB	
SNRmax	40.47dB	
Sensitivity	2058mV	
Dark current	0.15mV	
Gain range	1x-50x	
Exposure time	6 μs -15sec	
Shutter	Global shutter	
Binning	Software2x2, 3x3, 4x4	
Digital I/O	One optical-coupling isolated input, one optical-coupling isolated output, two non-isolated input and output	
Data Format	8bit / 12bit	
	General specification	
Power supply	Power with USB3.0 or 12V Power adapter	12V Power adapter
Power consumption	25.2W	TBD
Temperature	Working temperature -10~50°C, storage temperature -30~70°C	
Humidity	20%-80%, no condensation	
Size	80mm x 80mm x 101.5mm	
Weight	860g	
Lens mount	C-mount	
Software	EHDView/ SDK	
Platform and architecture	Win32/WinRT/Linux/macOS/Android; X86/X64/armhf/armel/arm64	
Certification	CE, FCC	

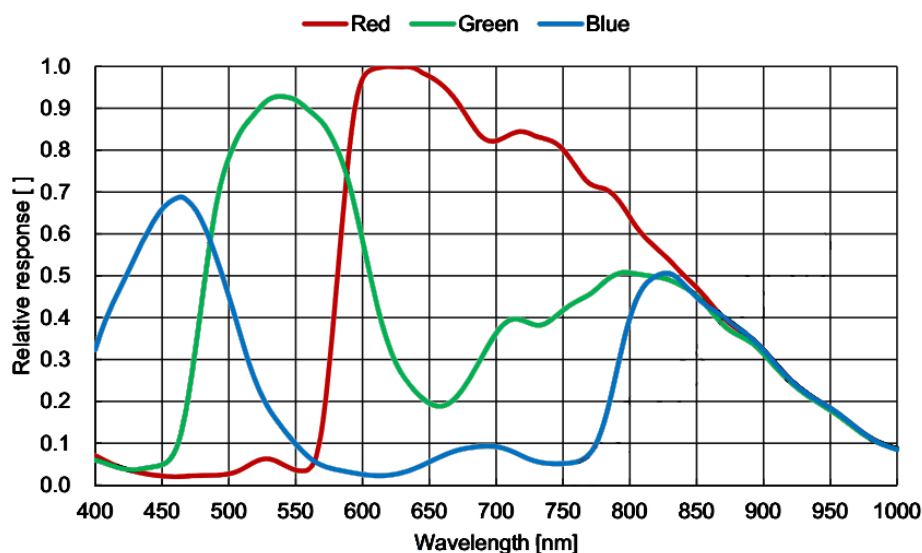

Figure 3-17 SC428C-ITR spectral response curve

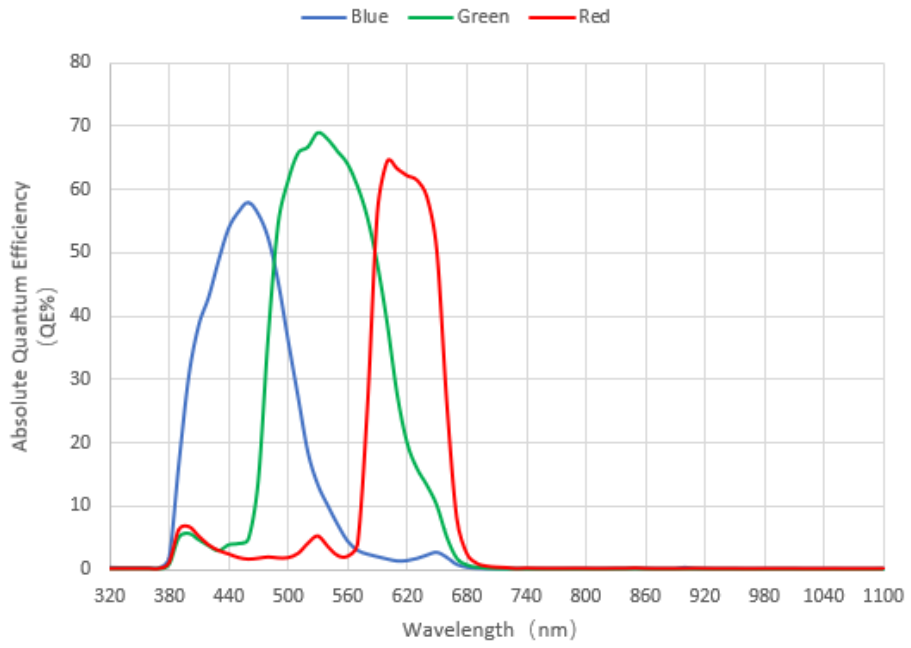

Figure 3-18 SC428C-ITR spectral absolute quantum efficiency

3.13 SC428-M-ITR

Table 3-13 SC428-M-ITR camera specifications

Model Parameter	ITR3CMOS07100KMA	ITR3CMOS07100KMA-G
	7.1M pixels 1.1" CMOS USB3.0 / GigE industrial camera	
Camera		
Data interface	USB3.0	GigE
Sensor model	Sony IMX428LLJ	
Pixel size	4.5 μm x 4.5 μm	
Sensor size	1.1"	
Frame rate	51.4fps@3200 x 2200 133.8fps@1584 x 1100	16.4fps@3200 x 2200 66fps@1584 x 1100
Readout Noise	2.38e-	
Full Well	11154.09e-	
Dynamic range	72dB	
SNRmax	40.47dB	
Sensitivity	3354mV	
Dark current	0.15mV	
Gain range	1x-50x	
Exposure time	6 μs -15sec	
Shutter	Global shutter	
Binning	Software2x2, 3x3, 4x4	
Digital I/O	One optical-coupling isolated input, one optical-coupling isolated output, two non-isolated input and output	
Data Format	8bit / 12bit	
General specification		
Power supply	Power with USB3.0 or 12V Power adapter	12V Power adapter
Power consumption	25.2W	TBD
Temperature	Working temperature -10~50 $^{\circ}\text{C}$, storage temperature -30~70 $^{\circ}\text{C}$	
Humidity	20%-80%, no condensation	
Size	80mm x 80mm x 101.5mm	
Weight	860g	
Lens mount	C-mount	
Software	EHDView/ SDK	
Platform and architecture	Win32/WinRT/Linux/macOS/Android; X86/X64/armhf/armel/arm64	
Certification	CE, FCC	

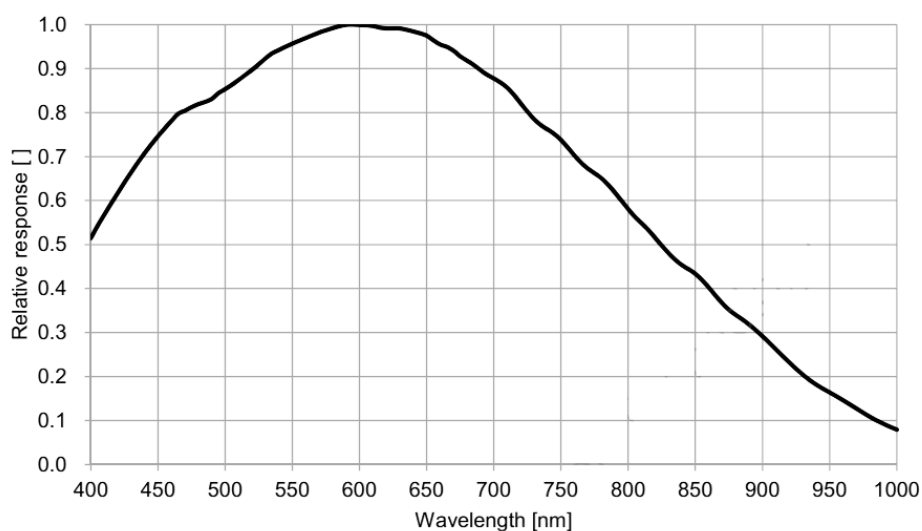

Figure 3-19 SC428-M-ITR spectral response curve

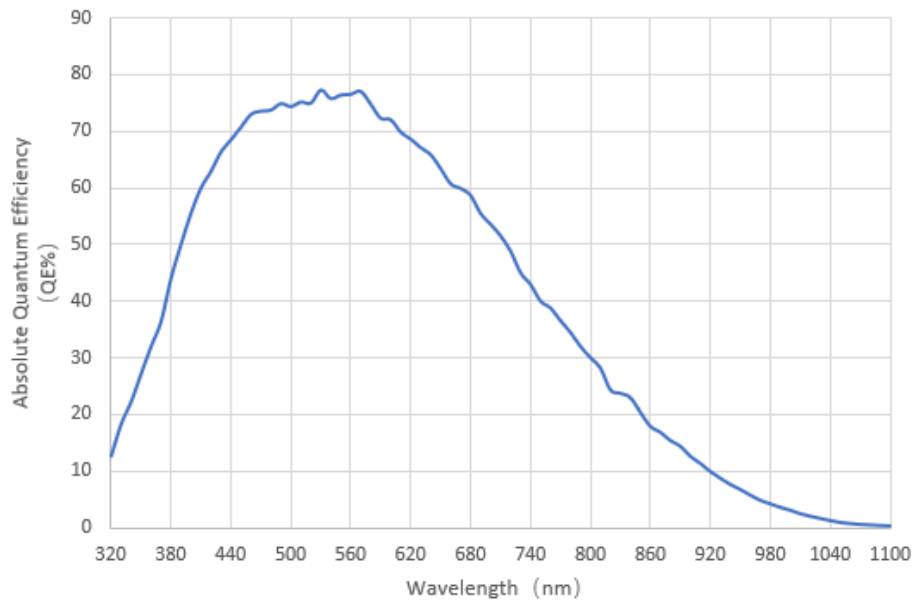

Figure 3-20 SC428M-ITR spectral absolute quantum efficiency

3.14 SC432C-ITR

Table 3-14 SC432C-ITR camera specifications

Model Parameter	ITR3CMOS01700KPA	ITR3CMOS01700KPA-G
	1.7M pixels 1.1" CMOS USB3.0 / GigE industrial camera	
	Camera	
Data interface	USB3.0	GigE
Sensor model	Sony IMX432LQJ	
Pixel size	9.0 μm x 9.0 μm	
Sensor size	1.1"	
Frame rate	98.6fps@1600 x 1100	66fps@1600 x 1100
Readout Noise	TBD	
Full Well	TBD	
Dynamic range	TBD	
SNRmax	TBD	
Sensitivity	4910mV	
Dark current	0.3mV	
Gain range	1x-50x	
Exposure time	6 μs -15sec	
Shutter	Global shutter	
Binning	Software 2x2, 3x3, 4x4	
Digital I/O	One optical-coupling isolated input, one optical-coupling isolated output, two non-isolated input and output	
Data Format	8bit / 12bit	
	General specification	
Power supply	Power with USB3.0 or 12V Power adapter	12V Power adapter
Power consumption	<25W	TBD
Temperature	Working temperature -10~50 $^{\circ}\text{C}$, storage temperature -30~70 $^{\circ}\text{C}$	
Humidity	20%-80%, no condensation	
Size	80mm x 80mm x 101.5mm	
Weight	860g	
Lens mount	C-mount	
Software	EHDView/ SDK	
Platform and architecture	Win32/WinRT/Linux/macOS/Android; X86/X64/armhf/armel/arm64	
Certification	CE, FCC	

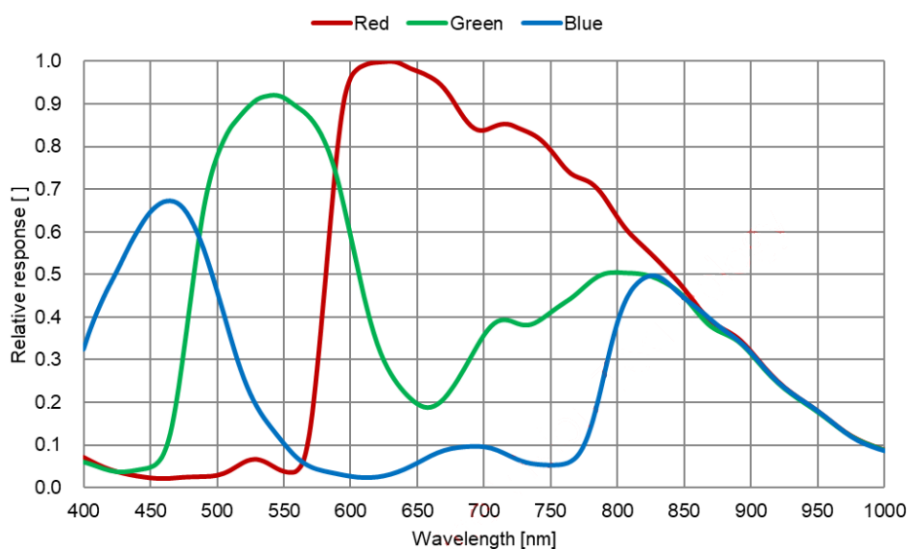

Figure 3-21 SC432C-ITR spectral response curve

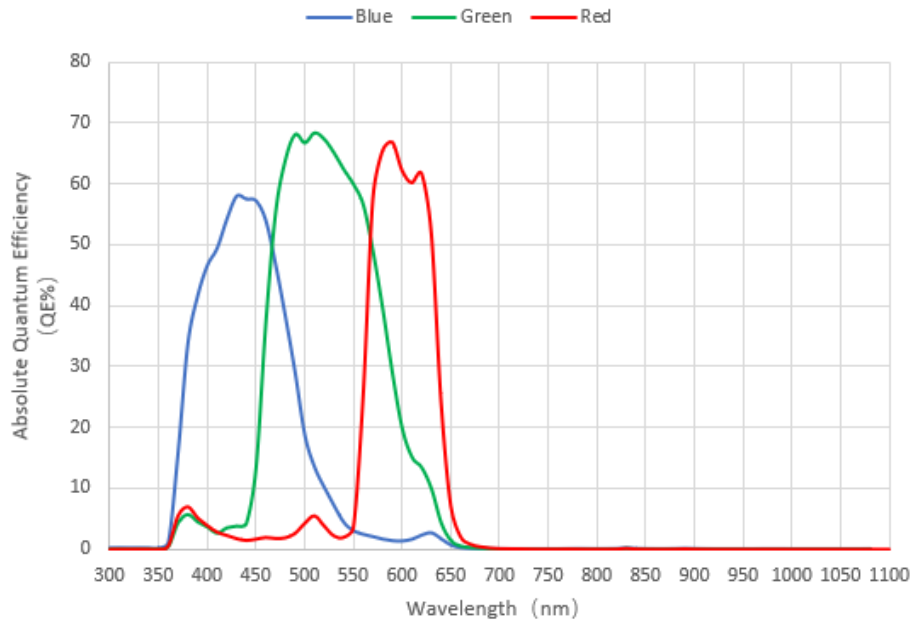

Figure 3-22 SC432C-ITR spectral absolute quantum efficiency

3.15 SC432M-ITR

Table 3-15 SC432M-ITR camera specifications

Parameter	Model	ITR3CMOS01700KMA	ITR3CMOS01700KMA-G
	1.7M pixels 1.1" CMOS USB3.0 / GigE industrial camera		
Camera			
Data interface		USB3.0	GigE
Sensor model	Sony IMX432LLJ		
Pixel size	9.0 μm x 9.0 μm		
Sensor size	1.1"		
Frame rate	98.6fps@1600 x 1100	66fps@1600 x 1100	
Readout Noise	TBD		
Full Well	TBD		
Dynamic range	TBD		
SNRmax	TBD		
Sensitivity	8100mV		
Dark current	0.3mV		
Gain range	1x-50x		
Exposure time	6 μs -15sec		
Shutter	Global shutter		
Binning	Software2x2, 3x3, 4x4		
Digital I/O	One optical-coupling isolated input, one optical-coupling isolated output, two non-isolated input and output		
Data Format	8bit / 12bit		
General specification			
Power supply	Power with USB3.0 or 12V Power adapter	12V Power adapter	
Power consumption	<25W	TBD	
Temperature	Working temperature -10~50 $^{\circ}\text{C}$, storage temperature -30~70 $^{\circ}\text{C}$		
Humidity	20%-80%, no condensation		
Size	80mm x 80mm x 101.5mm		
Weight	860g		
Lens mount	C-mount		
Software	EHDView/ SDK		
Platform and architecture	Win32/WinRT/Linux/macOS/Android; X86/X64/armhf/armel/arm64		
Certification	CE, FCC		

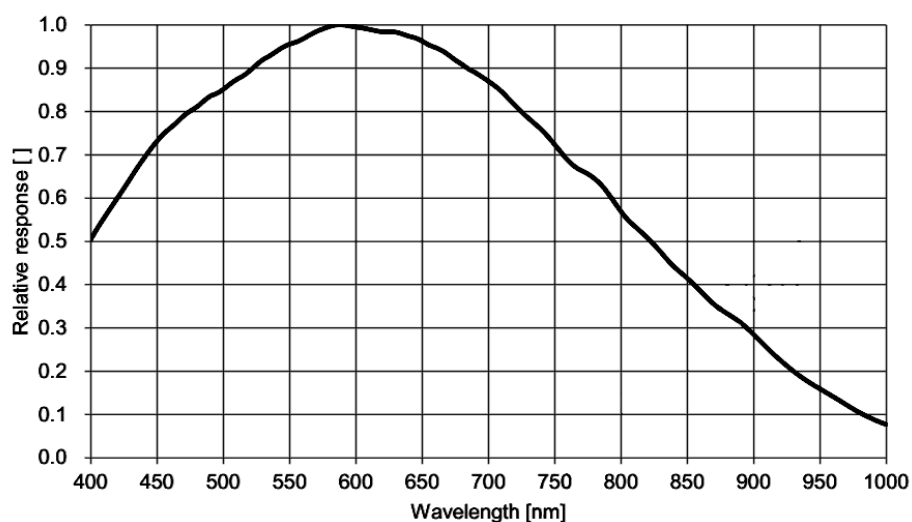

Figure 3-23 SC432M-ITR spectral response curve

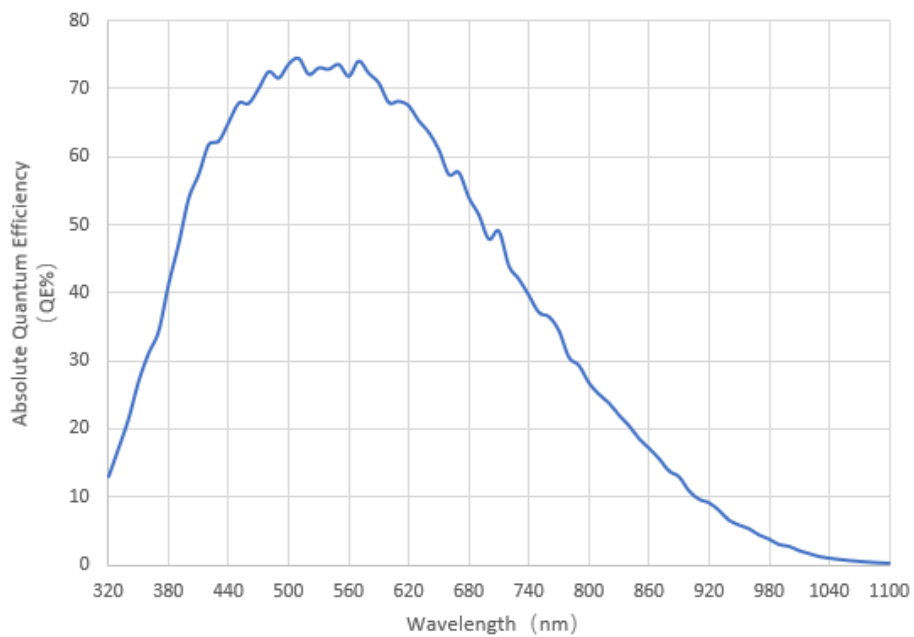

Figure 3-24 SC432M-ITR spectral absolute quantum efficiency

3.16 SC9701UV-ITR

Table 3-16 SC9701UV-ITR camera specifications

Model	ITR3CMOS01300KMA
Parameter	1.3M pixels 1" CMOS USB3.0 industrial camera
Camera	
Sensor model	GPixel GLUX9701BSI
Pixel size	9.76 μm x 9.76 μm
Sensor size	1"
Frame rate	30fps@1280 x 1024 30fps@640 x 512
Readout Noise	5.28e-(HCG) 35.19e-(LCG) 1.79e-(HDR)
Full Well	12927.7e-(HCG) 89855.19e-(LCG) 20205.74e-(HDR)
Dynamic range	67.78dB (HCG) 68.14dB (LCG) 81.08dB (HDR)
SNRmax	41.12dB(HCG) 49.54dB(LCG) 43.06dB(HDR)
Peak QE	89%@610nm
Sensitivity	$2.57 \times 10^8 \text{e}^- / ((\text{W}/\text{m}^2) \cdot \text{s}) @ 610\text{nm}$
Dark current	$2.07 \text{e}^- / \text{s}/\text{pix} @ -10^\circ\text{C}$ die temp
Gain range	1x-50x
Exposure time	63 μs -60sec
Shutter	Rolling shutter
Binning	Software 2x2, 3x3, 4x4, Hardware 2x2
Data interface	USB3.0 (USB3.1 GEN1)
Digital I/O	One optical-coupling isolated input, one optical-coupling isolated output, two non-isolated input and output
Data Format	8bit / HDR16bit
General specification	
Power supply	Power with USB3.0 or 12V Power adapter
Power consumption	<20W
Temperature	Working temperature $-10 \sim 50^\circ\text{C}$, storage temperature $-30 \sim 70^\circ\text{C}$
Humidity	20%-80%, no condensation
Size	80mm x 80mm x 101.5mm
Weight	860g
Lens mount	C-mount
Software	EHDView/ SDK
Platform and architecture	Win32/WinRT/Linux/macOS/Android; X86/X64/armhf/armel/arm64
Certification	CE, FCC

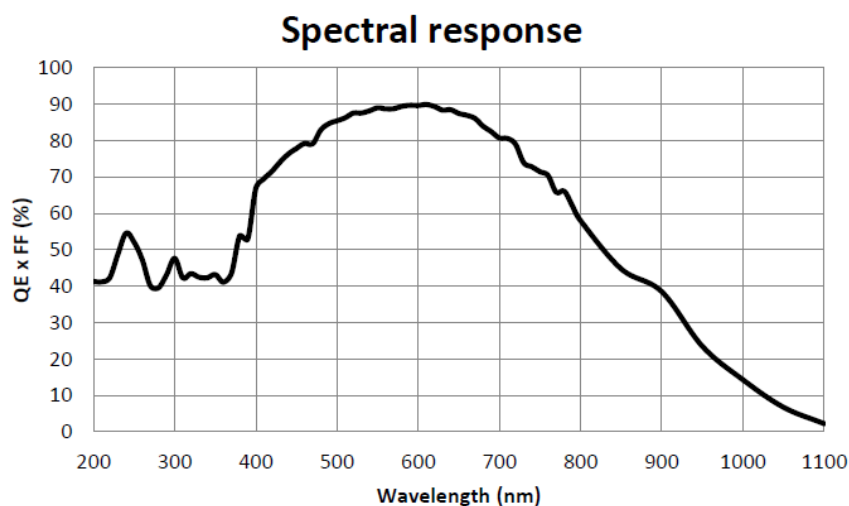

Figure 3-25 SC9701UV-ITR spectral response curve

3.17 SC1605UV-ITR

Table 3-17 SC1605UV-ITR camera specifications

Model	ITR3CMOS00500KMA
Parameter	0.5M pixels 1" CMOS USB3.0 industrial camera
Camera	
Sensor model	GPixel GLUX1605BSI
Pixel size	16 μm x 16 μm
Sensor size	1"
Frame rate	60fps@800 x 600 60fps@400 x 300
Readout Noise	5.88e-(HCG) 36.5e-(LCG) 2.71e-(HDR)
Full Well	13541.8e-(HCG) 89258.25e-(LCG) 46604.55e-(HDR)
Dynamic range	67.24dB (HCG) 67.77dB (LCG) 84.72dB (HDR)
SNRmax	41.32dB(HCG) 49.51dB(LCG) 46.68dB(HDR)
Peak QE	95%@560nm
Sensitivity	$6.4 \times 10^8 (e^- / ((W/m^2).s))$
Dark current	3.71e-/s/pix@ -10°C die temp
Gain range	1x-50x
Exposure time	27μs-60sec
Shutter	Rolling shutter
Binning	Software 2x2, 3x3, 4x4, Hardware 2x2
Data interface	USB3.0 (USB3.1 GEN1)
Digital I/O	One optical-coupling isolated input, one optical-coupling isolated output, two non-isolated input and output
Data Format	8bit / HDR16bit
General specification	
Power supply	Power with USB3.0 or 12V Power adapter
Power consumption	<20W
Temperature	Working temperature -10~50°C, storage temperature -30~70°C
Humidity	20%-80%, no condensation
Size	80mm x 80mm x 101.5mm
Weight	860g
Lens mount	C-mount
Software	EHDView/ SDK
Platform and architecture	Win32/WinRT/Linux/macOS/Android; X86/X64/armhf/armel/arm64
Certification	CE, FCC

Spectral response

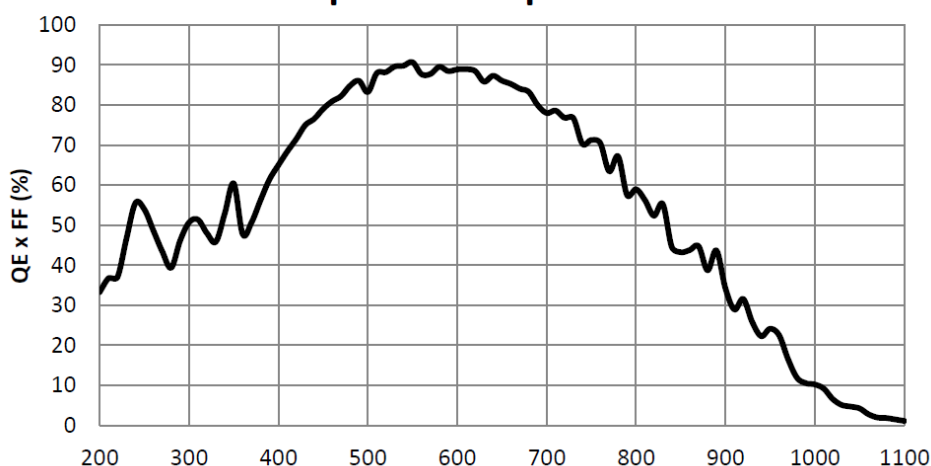

Figure 3-26 SC1605UV-ITR spectral response curve

12.3 SC-ITR Series USB3 Camera

12.3.1 Mechanical Housing Dimensions

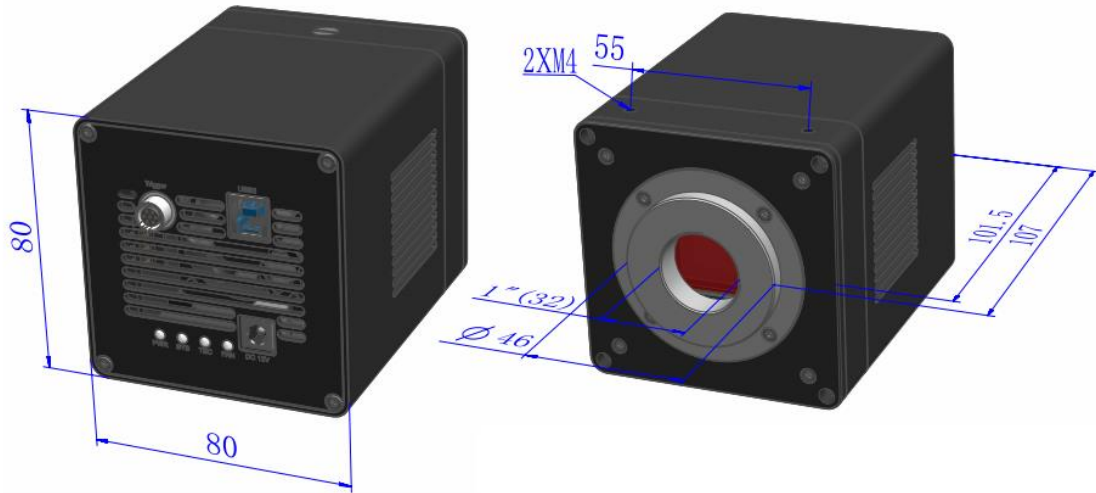

Figure 12-11 SC-ITR dimensions (mm)

12.3.2 Interface Description

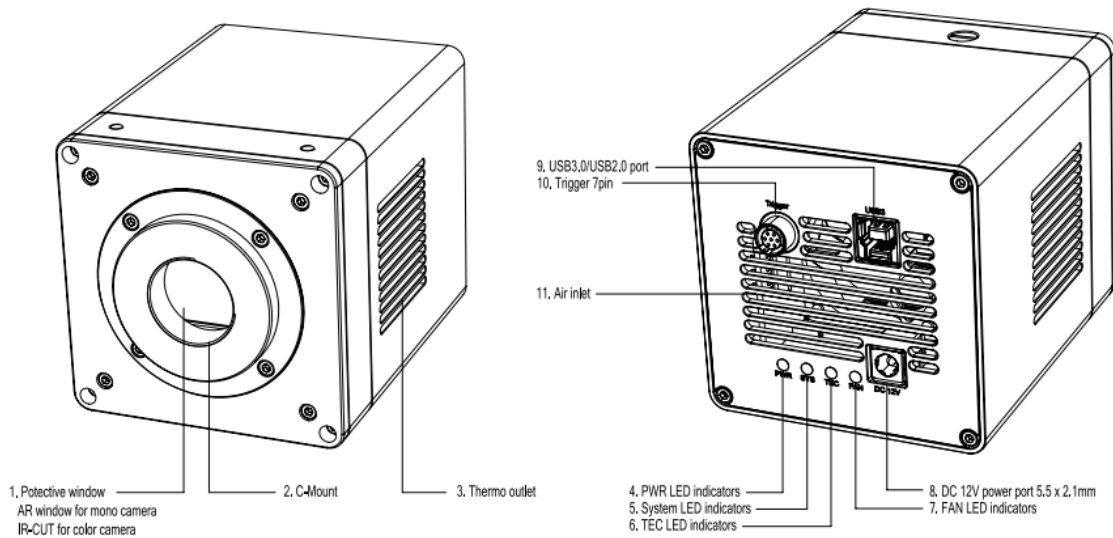

Figure 12-12 SC-ITR Camera interface diagram

Table 12-8 SC-ITR Camera interface definition

Item	Specification
1	Protective window: AR window for mono camera; IR-CUT for color camera
2	C mount
3	Thermo outlet
4	Power LED indicators
5	System LED indicators
6	TEC LED indicators
7	FAN LED indicators
8	DC 12V power port
9	USB 3.0/ USB 2.0 port
10	Trigger 7PIN

11	Air inlet
----	-----------

12.3.3 Power Supply and I/O Connector

Table 12-9 MaxCam series pin signal definition

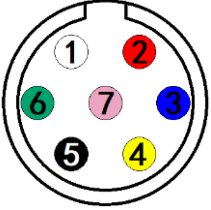
	Color	Pin	Signal	Signal description
	White	1	GND	Direct-coupled signal ground
Red	2	12V	12VDC power input or output	
Blue	3	OPTO GND	Opto-isolated signal ground	
Yellow	4	DIR_GPIO0	Direct-coupled General Purpose I/O (Software configurable input/output) (line2)	
Black	5	DIR_GPIO1	Direct-coupled General Purpose I/O (Software configurable input/output) (line3)	
Green	6	OPTO IN	Opto-isolated input signal (line0)	
Pink	7	OPTO OUT	Opto-isolated output signal (line1)	

12.3.4 Packing Information

Table 12-10 Recommended accessories

Order number	Accessories name	Quantity	Instruction
1	Camera	1	Camera referred in this manual
	Power adapter	1	Input: AC 100~240V 50Hz/60Hz,output: DC 12V 3A
2	I/O cable	1	7 Pin cable or extended cable
3	Cable	1	USB3.0 cable
4	Lens (optional)	1	C-mount lens

12.4 SC-ITR Series GigE Camera

12.4.1 Mechanical Housing Dimensions

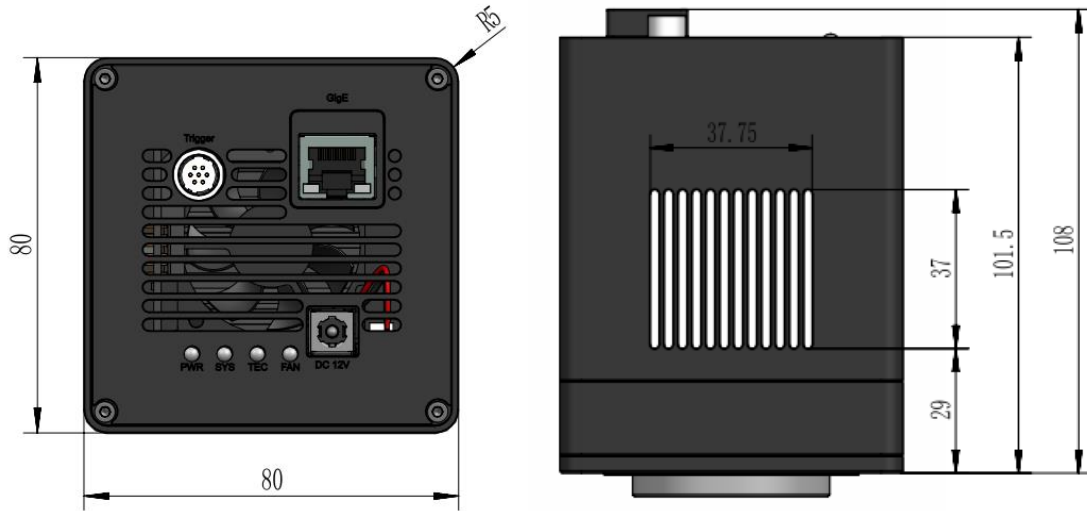

Figure 12-13 SC-ITR dimensions (mm)

12.4.2 Interface Description

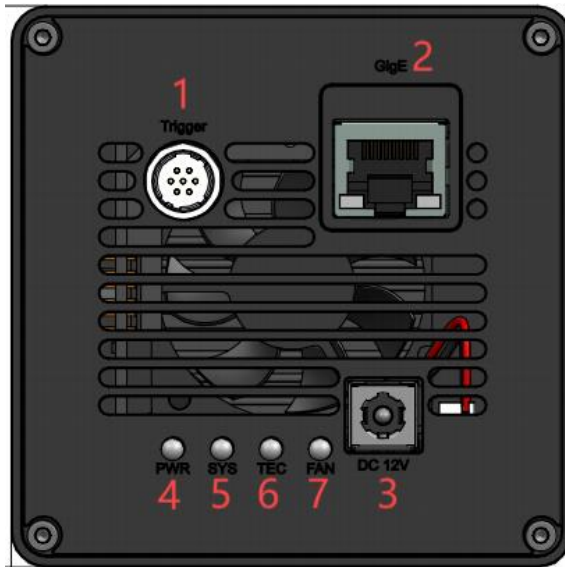

Figure 12-14 SC-ITR Camera interface diagram

Table 12-11 SC-ITR Camera interface definition

Item	Specification
1	Trigger 7PIN
2	GigE port
3	DC 12V power port
4	Power LED indicators
5	System LED indicators
6	TEC LED indicators
7	FAN LED indicators

12.4.3 Power Supply and I/O Connector

Table 12-12 SC-ITR series pin signal definition

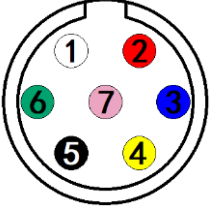
	Color	Pin	Signal	Signal description
	White	1	GND	Direct-coupled signal ground
	Red	2	12V	12VDC power input or output
	Blue	3	OPTO_GND	Opto-isolated signal ground
	Yellow	4	DIR_GPIO0	Direct-coupled General Purpose I/O (Software configurable input/output) (line2)
	Black	5	DIR_GPIO1	Direct-coupled General Purpose I/O (Software configurable input/output) (line3)
	Green	6	OPTO_IN	Opto-isolated input signal (line0)
	Pink	7	OPTO_OUT	Opto-isolated output signal (line1)

12.4.4 Packing Information

Table 12-13 Recommended accessories

Order number	Accessories name	Quantity	Instruction
1	Camera	1	Camera referred in this manual
	Power adapter	1	Input: AC 100~240V 50Hz/60Hz,output: DC 12V 3A
2	I/O cable	1	7 Pin cable or extended cable
3	Cable	1	GigE cable
4	Lens (optional)	1	C-mount lens

14 Description of Functions

14.1 Camera Capture Mode

Camera operation mode support: Video Mode or Trigger Mode.

Camera trigger mode supports: Soft Trigger Mode(Software) or External Trigger Mode(Isolated input, GPIO0, GPIO1, Counter or PWM).

14.2 ROI Control

Partial cameras supports hardware ROI. The smaller the ROI size, the faster the frame rate.

14.3 Bandwidth and Precise Frame Rate Control

14.3.1 Bandwidth

Partial cameras supports bandwidth adjustment from 1% to 100%. As shown in Figure 14-1, the camera is with 100% bandwidth by default, and you can drag the slider to set the desired bandwidth.

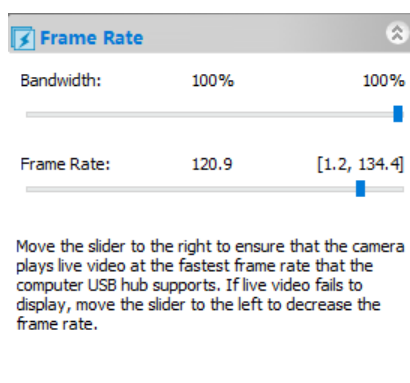

Figure 14-1 Bandwidth and precise frame rate settings

14.3.2 Precise Frame Rate Control

Partial cameras series supports precise frame rate control. The frame rate range will vary based on bandwidth, bit depth, resolution, ROI. As shown in Figure 14-1, the current frame rate can be set by dragging the Bandwidth or Frame Rate slider bar left or right.

14.4 DDR3 Buffer

Camera has a built-in 512MB (4Gb) DDR3 buffer, which can effectively improve the stability of USB3.0 data transmission and ensure that the camera does not lose frames when working.

14.5 Binning

Camera supports additive or averaged 1x1 to 8x8 digital binning, and averaged 1x1 to 2x2 hardware binning. Hardware binning can achieve higher frame rates than software binning.

14.6 Power Supply and Cooling System

MaxCam series adopts DC19V power supply, SC-ITR series and SC-CTR series adopts DC12V power supply. When DC19V or DC12V power supply is plugged in, both the camera cooling system and the imaging system use a unified 19V or 12V power supply.

When the power is disconnected, the camera cooling system stops working, and the imaging system will automatically switch to the USB 5V power supply and the camera can work normally in passive cooling mode.

The cooling system of the camera is TEC cooling, using an external cooling structure and fan assisted cooling, the operating temperature can be adjusted to a specific value, the effective cooling temperature can be lower than the ambient temperature 10-25°C, the efficient cooling system ensures a very low level of dark current.

TEC system adopts PID algorithm to control, so that the TEC can be accurately adjusted to the target temperature, and the temperature deviation is 0.1°C.

There is a Cooling group on the left sidebar in EHDView. To enable the Cooling function, an external 12V power supply is required. By default, the TEC is turned on. One can set the Target Temperature. After entering the value, click "Apply", and the sensor temperature will gradually approach to the Target time, EHDView can display the current temperature in real time, as shown in Figure 14-2.

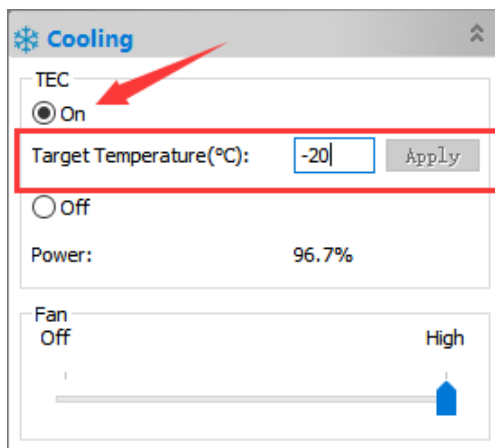

Figure 14-2 TEC settings

The Fan has two gears from Off to High. When High, the Fan speed reaches the highest. When Off, the Fan is turned off, the TEC is also turned off, and the power is 0, as shown in Figure 14-3.

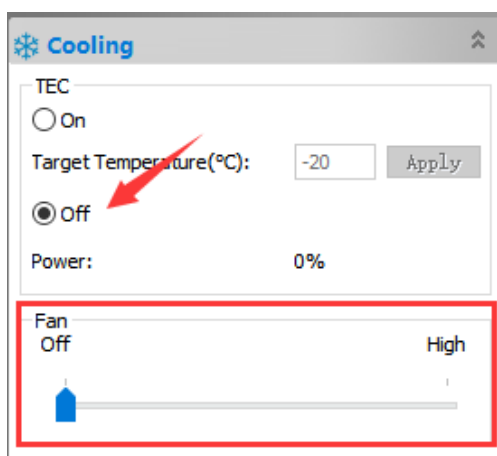

Figure 14-3 Fan settings

When the TEC is turned on, the Fan will automatically turn on preventing the abnormal situation such as the housing temperature is too high if the Fan stops running when the TEC is working; when the Fan is turned off, the TEC will automatically turn off.

15 Trigger Mode and its Configuration

15.1 Video Mode and Trigger Mode

The trigger function can be found on the **Capture & Resolution** group on the **Camera Sidebar** in EHDView. When the camera is opened, it is in **Video Mode** as shown in Figure 15-1 on the left. In **Video Mode**, **Auto Exposure**, **Exposure Target**, **Exposure Time** and **Gain** can be set. One can switch to **Trigger Mode** by checking the **Trigger Mode** check box.

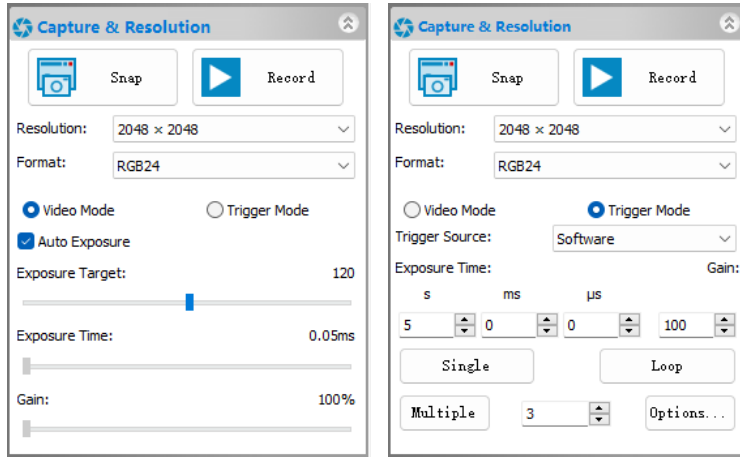

Figure 15-1 Video Mode and Trigger Mode on the Capture & Resolution group in EHDView

After the **Trigger Mode** is checked, the **Capture & Resolution** group will switch to **Trigger Mode** as shown in Figure 15-1 on the right. Where, the **Trigger Source**, **Exposure Time**, **Gain**, **Single**, **Loop**, **Multiple**, **Frame Box**, and **Options** can be set.

15.2 Trigger Sources and Their Capture Style

The **Trigger Source** can be any external input signal inputted into the camera which is called **Hardware (Trigger Source)**, it can also be a command from the application which is called **Software (Trigger Source)**. For the **Software Trigger Source**, it can be **Single**, **Loop**, **Multiple**, or **Sequence** style. Figure 15-2 shows the possible **Trigger Sources**. Table 15-1 shows the designed **Trigger Source** descriptions and possible capture styles for Touptek camera.

- Isolated input
- GPIO0
- GPIO1
- Counter
- PWM
- Software

Figure 15-2 Possible Trigger Sources

Table 15-1 Description of possible Trigger Sources and their capture styles

Trigger Source	Description
Isolated input	Logic 0 input level: 0~2.2VDC; Logic 1 input level: 3.3~24VDC; Maximum input current: 30mA;
GPIO0	Logic 0 input level: 0~0.6VDC (DIR_GPIO0/DIR_GPIO1 pins); Logic 1 input level: 2.0~24VDC (DIR_GPIO0/DIR_GPIO1 pins); Maximum input current: 25mA; If GPIO0 is chosen as Trigger Source , it should be configured as Input in the GPIO Mode 's combo box on the Options>IO Control page;
GPIO1	Logic 0 input level: 0~0.6VDC (DIR_GPIO0/DIR_GPIO1 pins); Logic 1 input level: 2.0~24VDC (DIR_GPIO0/DIR_GPIO1 pins); Maximum input current: 25mA; If GPIO1 is chosen as Trigger Source , it should be configured as Input in the GPIO Mode 's combo box on the Options>IO Control page;
Counter	Counter refers to the operation mode in which the camera can divide the frequency of the external input trigger signal through the preset Counter Value and perform image acquisition according to the customer's logic. For example, when the counter value (Counter Value: <input type="text" value="3"/> [1,1023]) is set to 3, the

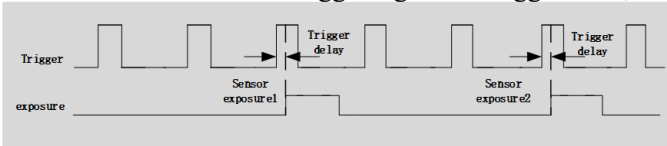
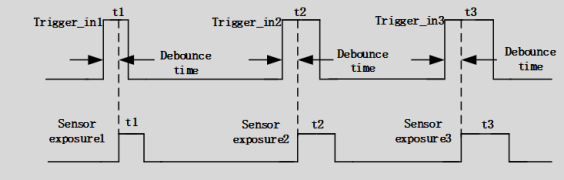
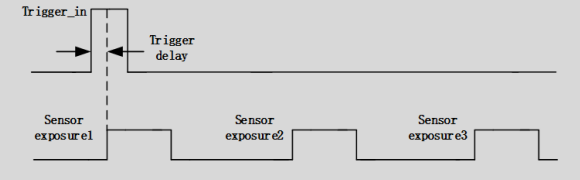
	<p>camera needs to receive 3 trigger signals to trigger once;</p>  <p>When Counter is chosen in Trigger Source combo box in the Capture & Resolution group, the Counter Source can be Isolated input, GPIO0 or GPIO1 which can be chosen on Options>IO Control page; If GPIO0 or GPIO1 is chosen in the Counter Source combo box on Options>IO Control page. It should be configured as Input in the GPIO Mode combo box; Check Options>IO Control page's Line Select related items and Counter related items for details;</p>
<p>PWM</p>	<p>PWM refers to the operation mode in which the camera exposure time is controlled by the input trigger signal's pulse width;</p>  <p>PWM Trigger Source can be Isolated input, GPIO0 or GPIO1. If GPIO0 or GPIO1 is chosen in the PWM Source combo box on the Options>IO Control page, it should be configured as Input in the GPIO Mode combo box; Check Options>IO Control page's Line Select related items and PWM related items for details;</p>
<p>Software</p>	<p>When Software trigger is chosen, the client software can send the command through USB3.0 to trigger, acquire and transfer images, In EHDView, Single, Loop, Multiple, or Sequence can be used to send the Software trigger command;</p> <p>If the Plan or Hardware is chosen in the Type combo box on the Options>Sequence page, the Multiple button will switch to Sequence button and the camera will use the Exposure Time and Gain in the Sequence table on this page one by one to capture the specified frames.</p> <p>Check Single, Loop, Multiple, or Sequence on Capture & Resolution group for the Software capture operations;</p> <p>Check Options>Sequence page and Options>Advanced page for the related Sequence and Software capture setup options;</p>
<p>Single</p>	<p>When Single is clicked, the camera will start to capture the image. At the same time the Single button will switch to Stop button. Clicking Stop button to stop the current Single capture operation, the Stop button will switch to Single button again for the next capture operation;</p> <p>Note:</p> <ol style="list-style-type: none"> 1) The captured frames will always Show in the video window to prevent too many captures; 2) Enabled when Software in the Trigger Source combo box is chosen or Always enable software trigger checkbox is checked on the Options>Advanced property page;
<p>Loop</p>	<p>When Loop is clicked, the camera will start to capture the image continuously and the Loop button will switch to Stop button. Clicking Stop button to stop Loop captures and the Stop button will switch to Loop button for the next Loop capture operation;</p> <p>Note:</p> <ol style="list-style-type: none"> 1)The captured frames will always Show in the video window to prevent too many captures; 2)Enabled to capture continually when Software in the Trigger Source combo box is chosen or Always enable software trigger checkbox is checked on the Options>Advanced property page;
<p>Multiple</p>	<p>Multiple refers to the operation mode in which the camera receives Software trigger signal or command and exports multiple frames of images. An edit box with spin(we call it Frames Box) is designed and affiliated to the Multiple button (Multiple <input type="text" value="3"/> Options...) for the setting of the frames to be captured;</p> <p>The Frames Box can be set in the range of 1~ 65535. If the Frames Box is 3, a three-frame image will be captured and exported;</p>  <p>Note:</p> <ol style="list-style-type: none"> 1)Multiple capture is enabled to capture continually when Software in the Trigger Source combo box is chosen; 2) Multiple capture is enabled when Always enable software trigger is checked on the Options>Advanced property page, no matter whether Trigger Source is Software or Hardware on the Capture & Resolution group; 3) If the Plan or Hardware is chosen in the Type combo box on the Options>Sequence page, the Multiple button will switch to Sequence button and the camera will use the Exposure Time and Gain in the Sequence table on this page. The captured frames will be displayed either in Show in the video window, or Show in a new window or Save to disk which can be specified on Options>Output page;
<p>Sequence</p>	<p>When Sequence is clicked, the camera will start to capture the image until the specified frames in the Frames Box are captured. At the same time the Sequence button will switch to Stop button. Clicking Stop button will stop the current Sequence capture and the Stop button will switch to Sequence again for the next Sequence capture operation;</p> <p>Note:</p> <ol style="list-style-type: none"> 1) Switched from Multiple to Sequence to capture the specified frames in the edit box with spin(Frames Box) when Plan or Hardware in the Type combo box is chosen on the Options>Sequence property page; 2)If the Plan or Hardware is chosen in the Type combo box on the Options>Sequence page, the Sequence button will be enabled and the capture will use the Exposure Time and Gain in the Sequence table list below one by one on the

Options>Sequence page;

3) If the **Plan** or **Hardware** is chosen in the **Type** combo box on the **Options>Sequence** page and **Always enable software trigger** is checked on the **Options>Advanced** property page, the **Sequence** button will not switch to **Multiple** button and will be enabled only when the still in Sequence enable

4) If the **Plan** is chosen in the **Type** combo box on the **Options>Sequence** page and the **Software** is chosen in the **Trigger Source** combo box, the **Sequence** button will be enabled.

5) If the **Hardware** is chosen in the **Trigger Source** combo box, the **Sequence** button will be disabled, but the **Frame Box** will still be enabled and the **Sequence** will switch to the **Hardware Sequence** capture. One **Hardware** trigger signal will capture the specified frames on the **Frame Box** using the **Exposure Time** and **Gain** in the **Sequence table** on **Options>Sequence** page;

6) Check **Options>Sequence** page for the related **Sequence** setup options;

15.3 The trigger capture and IO Control configurations

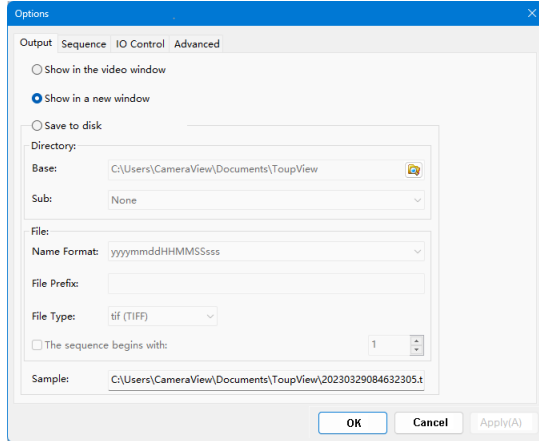

Figure 15-3 Options>Output page

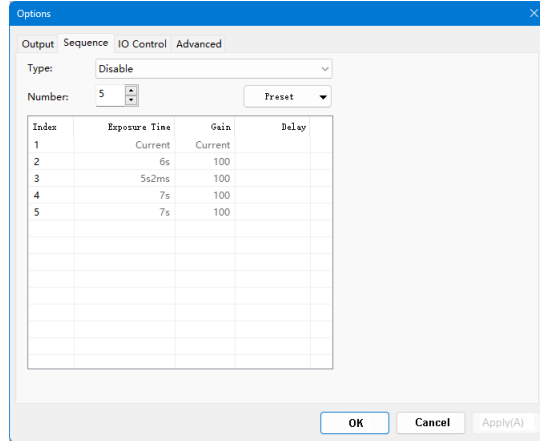

Figure 15-4 Options>Sequence page

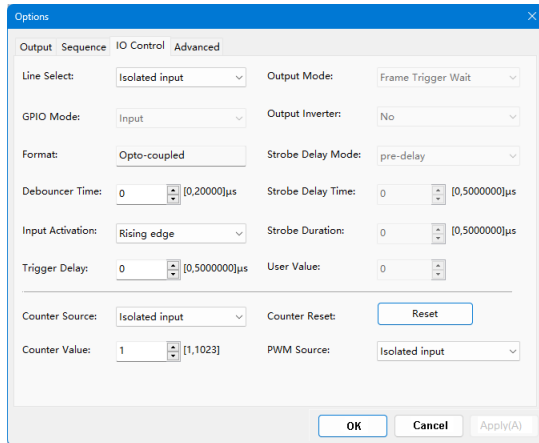

Figure 15-5 Options>IO Control page

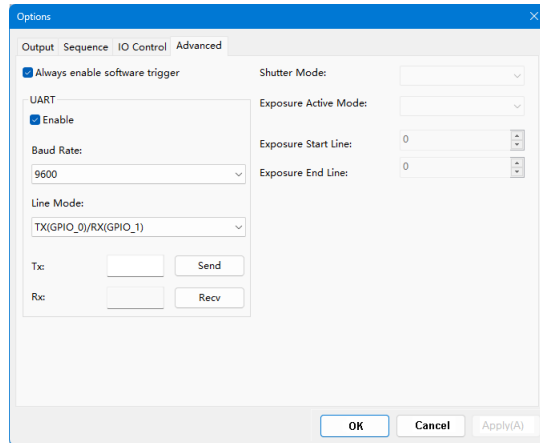

Figure 15-6 Options>Advanced page

The **Trigger Source** can be **Isolated input**, **GPIO0**, **GPIO1**(when configured as input), **Counter**, or **PWM** which can be configured on the **Options** property sheet. Also the camera's **Isolated output**, **GPIO0** or **GPIO1**(can be configured as **Output**) can be used as **Output** or **UART** (**GPIO0**, **GPIO1** only) applications. All of these configurations can be realized on the **Options** property sheet described in Table 15-2 below.

About the captured file operation style, one can find it on the **Option>Output** page;

About the **Sequence** setup, one can find it on the **Option>Sequence** page;

About the camera pin **IO Control** style, one can find it on the **Options>IO Control** page;

About the **Always enable software trigger** and **UART** setup, **Shutter Mode**, and **Exposure Active Mode**, one can find it on the **Options>Advance** page.

Table 15-2 Options property sheet for Trigger Source or camera pin configuration

Pages	Items	Descriptions
-------	-------	--------------

Output page	Output Destination	<p>Used to set the captured frame's Output destination, can be Show in the video window, Show in a new window or Save to disk;</p> <p>When Save to disk is checked, the  button will be enabled clicking it to choose the Base directory, clicking the Sub combo box's dropdown button to choose the Sub directory;</p> <p>The File Name Format, File Prefix, File Type, and even The sequence begin with can be chosen, set, or defined.</p> <p>Note:</p> <ol style="list-style-type: none"> 1)Valid only for Sequence or Multiple capture setup; 2)For Single or Loop capture, the captured image will be always displayed on the video window;
Sequence page	<p>Type</p> <p>Disable</p> <p>Plan</p> <p>Hardware</p>	<p>Disable: If the Disable button is chosen in the Type combo box on the Options>Sequence page, the Sequence button on the Capture & Resolution page will switch to Multiple button;</p> <p>Plan: 1)If Plan is chosen in the Type combo box on the Options>Sequence page, the Multiple button on the Capture & Resolution group will switch to Sequence button;</p> <p>2) If the Software Trigger Source is chosen in the Capture & Resolution group or the Always enable software trigger is checked on the Options>Advanced property page, the Sequence button will be enabled After the Software trigger signal is arrived(By clicking Single, Loop, or Sequence button), the camera will capture frames specified in the edit box with spin  3  (we call it Frames Box) affiliated to the Sequence button; The whole captures will use the Exposure Time, Gain and Delay in the Sequence table list under  3  one by one by the software;</p> <p>3) If the Disable button is chosen in the Type combo box on the Options>Sequence page, the Sequence button on the Capture & Resolution page will switch to Multiple button;</p> <p>4) The Sequence button will be enabled only when a) the Plan in the Type combo box is chosen on the Options>Sequence page and b) he Software Trigger Source is chosen in the Capture & Resolution group or c) Always enable software trigger is checked on the Options>Advanced property page;</p> <p>Hardware: 1) if Hardware is chosen in the Type combo box on the Options>Sequence page, the Multiple button on the Capture & Resolution group will switch to Sequence button and will be disabled for Hardware trigger. But users can still set the frames number in the Frame Box on the Capture & Resolution group;</p> <p>2) After the Hardware trigger signal arrives, the camera will capture frames specified in the edit box with spin  3  (we call it Frame Box) affiliated to the Sequence button; The whole capture will use the Exposure Time, Gain (Delay is not used) in the Sequence table list under  3  one by one but stored in the camera hardware for the quick operation;</p> <p>3) If the Disable button is chosen in the Type combo box on the Options>Sequence page, the Sequence button on the Capture & Resolution page will switch to Multiple button.</p> <p>4) The Sequence button is always disabled if a) The Hardware is chosen in the Type combo box on the Options>Sequence page and b)the Hardware Trigger Source is chosen in the Capture & Resolution group;</p> <p>5) The Sequence button will be enabled if a) the Software Trigger Source is chosen in the Capture & Resolution group or b) the Always enable software trigger checkbox is checked on the Options>Advanced property page, in this case, both the Plan and Hardware Sequence capture are supported;</p> <p>Number</p> <p>The possible Sequence(capture) frames to be captured. If the Number is larger than the Sequence Number in the Frames Box on the Capture & Resolution group, the other Indices will be executed at the next Sequence operation one by one recycled;</p> <p>Index</p> <p>The order of the Number group;</p> <p>Exposure Time</p> <p>The camera Exposure Time for the specified capture Index in the Sequence capture;</p> <p>Gain</p> <p>The camera Gain for the specified capture Index in the Sequence capture;</p> <p>Delay</p> <p>The Delay time for the specified capture Index in the Plan Sequence capture(Valid for Plan Sequence capture only);</p> <p>Preset</p> <p>Choosing Save to save the current Sequence table's settings;</p> <p>Clicking Management to Rename the saved Sequence table's setting files or Remove them from the Management list;</p>
IO Control page	<p>Line Select</p> <p>GPIO Mode</p> <p>Format</p> <p>Debouncer Time</p>	<p>Choosing which line to set. Can be Isolated input, Isolated output, GPIO0 or GPIO1 et al;</p> <p>To configure whether the line selected in Line Select is for Input or Output. Only GPIO0 or GPIO1 can be configured as either Input or Output;</p> <p>If Isolated input or Isolated output is chosen, the GPIO Mode will be specified as Input or Output (Not configurable) respectively;</p> <p>Specify the current selected signal's Format in the Line Select combo box, can be Opto-coupled(Isolated input, Isolated output)or TTL (GPIO0 or GPIO1)for clarity(Unconfigurable);</p> <p>Since there may be a glitch in the external trigger input signal if it directly enters into the internal logic circuit of the camera, it will cause false triggering, so the input trigger signal should be debounced. In addition, the effective pulse width of the trigger signal input by the user should be greater than the Debouncer Time, otherwise, the trigger signal will be ignored;</p> <p>When Isolated input, GPIO0 or GPIO1 is chosen in the Line Select combo box and GPIO0 or GPIO1 is configured as Input in the GPIO Mode combo box, the Debouncer Time will be enabled for the user to input the Debouncer Time between 0 to 20000us;</p>

	<p>Input Activation</p>	<p>When Isolated input, GPIO0 or GPIO1 is chosen in the Line Select combo box and GPIO0 or GPIO1 is configured as Input in the GPIO Mode combo box; The Input Activation combo box will be enabled to configure the Input Activation as either Rising Edge or Falling Edge;</p> <p>Also can be configure as high level or low level. When high level is selectd, the camera keeps triggering the frame when the input signal is high; When low level is selectd, the camera keeps triggering the frame when the input signal is low;</p>												
	<p>Trigger Delay</p>	<p>When Isolated input, GPIO0 or GPIO1 is chosen in the Line Select combo box and GPIO0 or GPIO1 is configured as Input in the GPIO Mode combo box, the Trigger Delay will be enabled for the user to input the Trigger Delay time between 0 to 5000000us; If the Trigger Delay time is set to 1000000us, the camera will wait for 1s to capture the image after receiving the trigger signal;</p>												
	<p>Output Mode</p> <ul style="list-style-type: none"> Frame Trigger Wait Exposure Active Strobe User Output Counter Output Timer Output 	<p>When Isolated output, GPIO0 or GPIO1 is selected in the Line Select combo box and GPIO0 or GPIO1 is configured as Output in the GPIO Mode combo box, the Output Mode will be enabled. It can be Frame Trigger Wait, Exposure Active, Strobe, User Output, Counter Output or Timer Output. The chosen mode can be used for diversified applications;</p> <p>The Frame Trigger Wait signal is pulled low at the start of exposure and pulled high when the last frame of data is read out. The trigger signal input by the user should be in the valid period. If the user inputs a trigger signal when the signal is low, the trigger signal input at this time will be ignored. The following example is the case when Burst Count = 2, as shown below;</p> <p>Exposure Active: when this signal is high, it means the sensor is exposing. This signal can be used to control an external mobile device to remain stationary or move at low speed while the camera is at exposure. The timing diagram of the exposure valid signal is shown below;</p> <p>When the relative position of the camera and the object to be photographed changes, you can refer to Exposure Active signal to prevent the captured image from being affected by movement and focus adjustment during the exposure process;</p> <p>When Strobe is chosen, Strobe Delay Mode, Strobe Delay Time, Strobe Duration will be enabled;</p> <p>When User Output is chosen, User Value will be enabled. lines3, line2, line1 are the combination of GPIO1, GPIO0 and Isolated output respectively. If User Value is 001, then line GPIO1 and GPIO0 will be disabled and Isolated output will be enabled;</p> <table border="1" style="margin-left: auto; margin-right: auto;"> <tr> <td></td> <td colspan="3" style="text-align: center;">LSB</td> </tr> <tr> <td>UserOutput Value:</td> <td style="text-align: center;">1</td> <td style="text-align: center;">0</td> <td style="text-align: center;">0</td> </tr> <tr> <td>Line:</td> <td style="text-align: center;">line3</td> <td style="text-align: center;">line2</td> <td style="text-align: center;">line1</td> </tr> </table> <p>When the CounterOutput is selectd, when the counter value is “m”, the camera triggers “m” times to output a signal.</p> <p>When the Timer Output is selectd, the camera keeps output signals. When the Strobe Delay Time is delay, the pulse width of the high level is determined by the Strobe Duration. The pulse width of low level is determined by the Strobe Delay Time.</p>		LSB			UserOutput Value:	1	0	0	Line:	line3	line2	line1
	LSB													
UserOutput Value:	1	0	0											
Line:	line3	line2	line1											

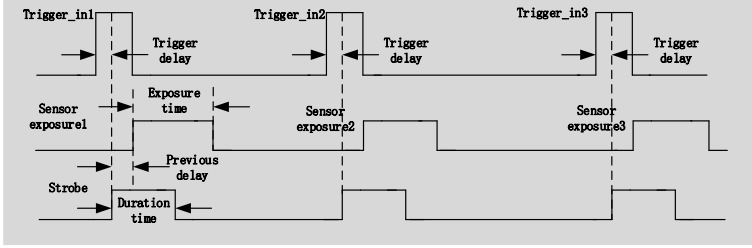
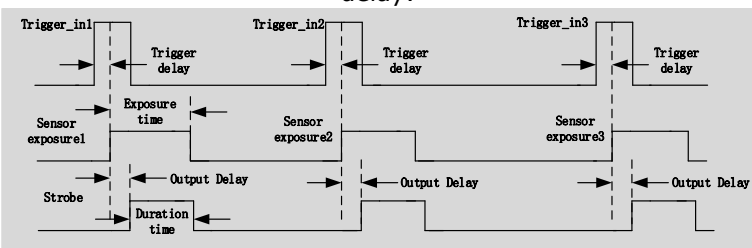
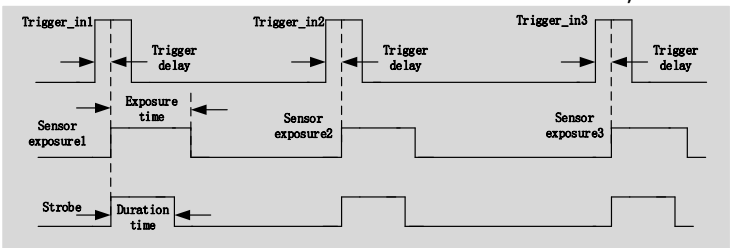
	Output Inverter	When Isolated output , GPIO0 or GPIO1 is selected in the Line Select combo box and Output is chosen for GPIO0 or GPIO1 in the GPIO Mode combo box, the Output Inverter will be enabled to configure the current selected line's output as either inverted or not(Yes or No).								
	Strobe Delay Mode	Strobe can be used to control external devices such as the strobe, and the effective level duration, delay time, and pre-delay time of the strobe signal can be set; When the Output Mode is Strobe , Strobe Delay Mode will be enabled. It can be pre-delay or delay ;								
	Strobe Delay Time	<p>When exposure starts, the strobe does not take effect immediately, and the output is delayed according to the value set by Strobe Delay Time which is between 0 to 5000000us. The Strobe Delay Mode can be pre-delay or delay; It is described below;</p> <p>pre-delay:</p>  <p>delay:</p> 								
	Strobe Duration	<p>The high level duration of the strobe is determined by the Strobe Duration which is between 0 to 5000000us as shown below;</p> 								
	User Value	<p>Users can input a value at User Value edit box with spin to control the line as disable or enable. Enabled when User Output is chosen in the Output Mode combo box. The logical value 0 or 1's combination of GPIO1(line3), GPIO0(line2) and Isolated output(line1);</p> <p>When the output mode is selected as User Output, the user can input a value at User Value edit box to control the corresponding line output with 0 or 1; The value here is only valid for the lower three bits of a binary. For example, when line 1 and line 3 are set to User Output mode, and its User Value is set to 4 ('b100'), then line 3 outputs 1, and line 1 outputs 0, as shown below.</p> <div style="border: 1px solid black; padding: 5px; width: fit-content; margin: 10px auto;"> <table style="border-collapse: collapse;"> <tr> <td style="padding: 2px;">UserOutput Value:</td> <td style="padding: 2px; text-align: center;">1</td> <td style="padding: 2px; text-align: center;">0</td> <td style="padding: 2px; text-align: center;">0</td> </tr> <tr> <td style="padding: 2px;">Line:</td> <td style="padding: 2px; text-align: center;">line3</td> <td style="padding: 2px; text-align: center;">line2</td> <td style="padding: 2px; text-align: center;">line1</td> </tr> </table> <p style="text-align: right; margin: 0;">LSB ↓</p> </div>	UserOutput Value:	1	0	0	Line:	line3	line2	line1
UserOutput Value:	1	0	0							
Line:	line3	line2	line1							
	Counter Source	When Counter is chosen in the Trigger Source combo box in the Capture & Resolution group, the Counter Source can be chosen from Isolated input , GPIO0 or GPIO1 in this combo box on the Option>IO Control page;								
	Counter Value	The Counter Value is used to divide the frequency of the external input trigger signal when the Counter Trigger Source is chosen in the Capture & Resolution group; See Counter in Table 15-1 for detail;								
	Counter Reset	Click Reset button can clear the current counting process and begin a new one;								
	PWM Source	When PWM is chosen in the Trigger Source combo box in the Capture & Resolution group, the PWM Source can be from Isolated input , GPIO0 , or GPIO1 in this combo box et al. ;								
Advanced page	Always enable software trigger	When this button is checked, no matter whether Trigger Source is Software or Hardware , the software trigger buttons(Single , Loop , Multiple) are always enabled; If the Plan or Hardware is chosen in the Type combo box on the Options>Sequence page, the Multiple button will switch to Sequence button; The Sequence button will be enabled if a)the Software Trigger Source is chosen								

		in the Capture & Resolution group or b) the Always enable software trigger checkbox is checked on the Options>Advanced property page, in this case, both the Plan and Hardware Sequence captures are supported;
	UART	There is a serial port function on the Advanced page, which can be used to communicate with external devices via serial port. Check Enable to enable this function. When enabled, GPIO0 and GPIO1 can only be used as UART transfers; The Baud Rate supports 9600-115200. Cable Select can configure GPIO0 and GPIO1 , which can be configured as TX or RX respectively. Setting a value at TX , clicking Send to send the set value out; click Accept at RX to receive the value from the external device;
	Shutter Mode	Enabled if the camera supports. Users can select Rolling Shutter or Global Reset ;
	Exposure Active Mode	Enabled if the camera supports. Users can select Specified lines or Common exposure time ;
	Exposure Start Line	Enabled when Specified lines in the Exposure Active Mode combo box is selected. To configure when the Exposure Active signal is valid;
	Exposure End Line	Enabled when Specified lines in the Exposure Active Mode combo box is selected. To configure when the Exposure Active signal is invalid;

16 Application

16.1 Application installation

In terms of software, customers are welcome to visit our website: <https://www.ehd.de/> to download the latest EHDView, also be used with ASCOM, DirectShow interface. If the third-party software is compatible with these interfaces, customers can also download software drivers from our website and install them into the third-party software.

16.2 Introduction to EHDView

EHDView is a professional software that integrates camera control, image acquisition and processing, image browsing and analysis functions. EHDView has the following characteristics:

- x86: XP SP3 and above ; CPU supports SSE2 and above
- x64: Win7 and above
- Support video mode and Trigger Mode (Raw format or RGB format)
- Automatic capture and quick recording capabilities
- Supports multiple languages
- Hardware ROI and digital binning capabilities
- Rich image processing functions, such as image stitching, real-time overlay, flat field correction, dark field correction, etc.
- Supports all ToupTek cameras

16.2.1 User interface design

- The menus and toolbars are properly set to ensure quick operation
- Professionally integrated with 5 sidebars - Camera, Folders, Undo/Redo, Layers, Measure
- Comfortable operation method (double-click or right-click context menu)
- Detailed help manual

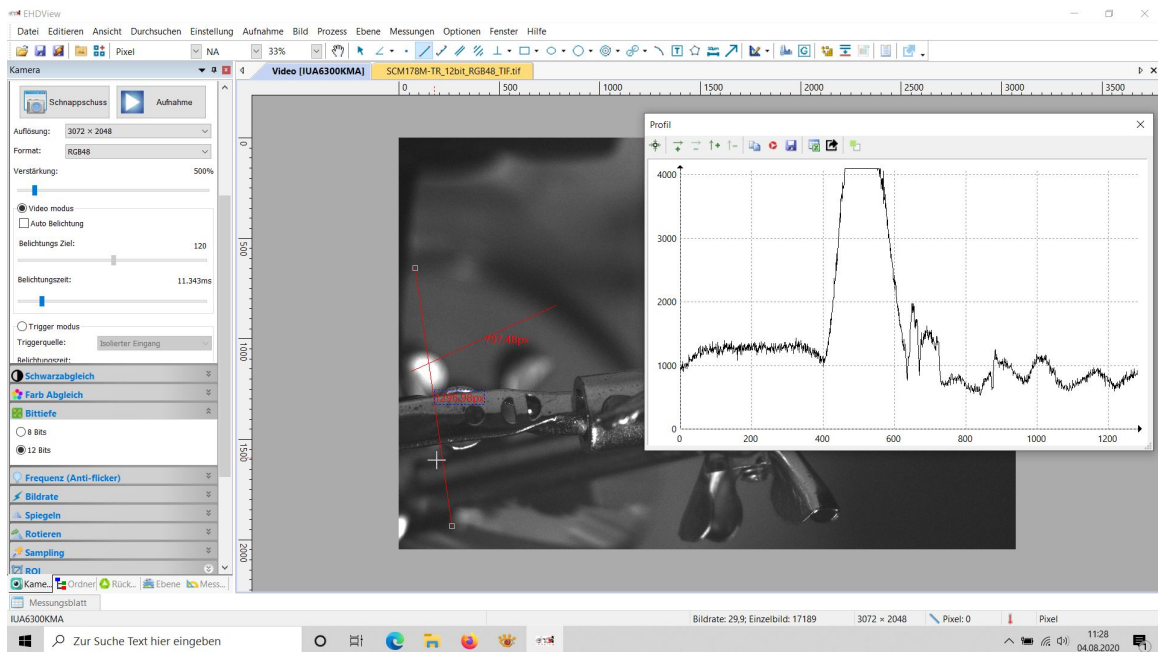

Figure 16-1 EHDView video window

16.2.2 Professional Camera Control Sidebar

Capture & Resolution	Set up live and still capture, snap images, or record video
Exposure & Gain	Auto exposure (preset exposure target value), manual exposure (exposure time can be manually entered and set by slider); gain up to 5 times
White Balance	Advanced one-click smart white balance settings, and you can adjust white balance by manually setting

	color temperature and color
Color Adjustment	Color, saturation, brightness, contrast, gamma initial high-speed adjustment function
Frame Rate Control	For different computer and USB performance, the camera can be super compatible by adjusting the frame rate
Flip	Select "Horizontal" or "Vertical" to adjust the sample orientation to ensure the same orientation as the visual system
Sampling	Neighborhood averaging can improve the signal-to-noise ratio of the video stream; while the sampling extraction mode can ensure the sharpness of the video stream. Supports histogram expansion of video stream, image negative and positive switching, grayscale calibration, and sharpness factor calculation to facilitate video focusing
Bit Depth	8, 12-bit switching, 8-bit is the basic Windows image format. 12-bit has higher image quality but reduces frame rate
Roi	ROI, Region of interest. This function can set the ROI value of the video window. After the ROI group is expanded, a rectangular box will appear in the middle of the video window, and the ROI can be changed. The mouse can adjust the size of the ROI. If there is no problem with the ROI, click "Apply" to set the video to the size of the ROI, and the default value will be restored to the original size.
Dark Field Correction	To enable darkfield correction, you should first capture a field image, then click Enable. Check Enable to enable darkfield correction. Uncheck it to disable darkfield correction
Cooling	Set TEC Target Temperature, fan on/off
Parameter Save	Load, save, overwrite, load, export custom camera panel controls (including calibration information, exposure parameters and color settings information, etc.)

16.2.3 Professional and practical image processing functions

Video Function	Various video professional processing functions: video broadcasting, timing capture, video recording, video watermarking, watermark mobile alignment, watermark rotation alignment, video grid overlay, video measurement, video scaling, gray scale calibration, video high dynamic (HDR), video depth of field extension, video image stitching, video scale, date, etc.
Image Processing and Enhancement	Image contrast control and adjustment, image denoising, various image filtering algorithms, image mathematical morphology algorithms, image rotation, image scaling and image printing, etc.
Image Overlay	The EHDView image overlay denoising function introduces advanced image matching technology. Users only need to record a short video of the image to be superimposed, and they can superimpose and output high fidelity in the case of displacement, rotation and magnification change between multiple frames of the video. images, easy to use

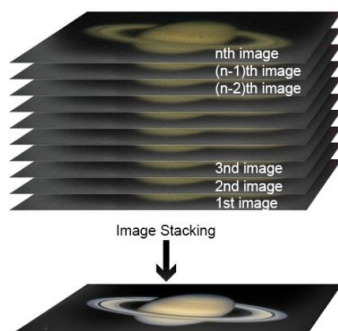

Figure 16-2 Image overlay denoising

16.2.4 Super compatibility

Camera Video Interface	Provide Twain, DirectShow, Labview, SDK installation package (native C++, C#)
Supported Platform and architectures	Compatible with Microsoft® Windows® XP / Vista / 7 / 8 /10 /11(32 & 64 bit), Mac OSX, Linux
Language Support	Language support can be added manually, currently supports English, Simplified Chinese, Traditional Chinese, German, Japanese, Russian, French, Italian, Polish, Turkish

16.2.5 Basic hardware requirements

PC Basic Configuration Requirements	CPU: Intel Core 2 2.8GHz or higher
	RAM: 2GB or more
	USB Port: USB3.0 / USB 2.0
	Monitor: 17" or higher
	CD-ROM

17 Software development instructions

17.1 SDK description

The download link of the SDK is as follows:

www.ehd.de/driver

17.1.1 SDK support platform

- Win32:
 - x86: XP SP3 and above; the CPU needs to support at least the SSE2 instruction set.
 - x64: Win7 and above.
 - arm: Win10 and above.
 - arm64: Win10 and above.
- WinRT: x86, x64, arm, arm64; Windows 10 and above.
- macOS: x86 and x64 bundle; macOS 10.10 and above.
- Linux: core 2.6.27 and above.
 - x86: The CPU needs to support at least the SSE3 instruction set; GLIBC 2.8 and above.
 - x64: GLIBC 2.14 and above.
 - armel: GLIBC 2.17 and above; compiled by toolchain arm-linux-gnueabi (version 4.9.2).
 - armhf: GLIBC 2.17 and above; compiled by toolchain arm-linux-gnueabi (version 4.9.2).
 - arm64: GLIBC 2.17 and above; compiled by toolchain aarch64-linux-gnu (version 4.9.2).
- Android: arm, arm64, x86, x64; compiled by android-ndk-r18b.

17.1.2 Introduction to SDK content

nncam series cameras support a variety of APIs, including: Native C/C++, .NET/C#/VB.NET, Python, Java, DirectShow, Twain, LabView, Matlab, etc. Compared with other APIs, Native C/C++ API as a low-level API is characterized by using pure C/C++ development without relying on other runtime libraries. The interface is simple and the control is flexible. This SDK zip package contains all the resources and information needed. The directory is as follows:

- inc:
 - nncam.h, the C/C++ header file.
- win: Microsoft Windows platform
 - file
 - ◆ dotnet:
 - nncam.cs, supports C#. nncam.cs uses P/Invoke to call nncam.dll. Please copy nncam.cs to your C# project for use.
 - nncam.vb, supports VB.NET. nncam.vb uses P/Invoke to call nncam.dll. Please copy nncam.vb to your VB.NET project for use.
 - ◆ x86:
 - nncam.lib, x86 lib file.
 - nncam.dll, x86 dynamic library file.
 - democpp.exe, x86 C++ demo execute the procedure.
 - x64:
 - nncam.lib, x64 lib file.
 - nncam.dll, x64 dynamic library file.
 - democpp.exe, x64 C++ demo execute the procedure.
- arm:
 - nncam.lib, arm lib file.

nncam.dll, arm dynamic library file.

- arm64:
nncam.lib, arm64 lib file.
nncam.dll, arm64 dynamic library file.
- winrt:
They can be applied for Dynamic library files of WinRT/ UWP (Universal Windows Platform)/ Windows Store App. They are compatible with Windows Runtime and can be referenced by Universal Windows Platform apps. If you use C# to develop UWP, you can use the nncam.cs wrapper class. Please pay attention to the Device Capability of uwp. Refer to how to add USB device capabilities to the app manifest. (Microsoft seems to limit the Device entry under DeviceCapability to no more than 100) demouwip.zip is a simple example of uwp. Please modify vid and pid. under DeviceCapability in the file Package.appxmanifest before compiling the run example.
- Drivers: (Cameras produced after 2017.1.1 support WinUSB, and drivers no longer need to be installed on Windows 8 and above)
The x86 folder contains the x86 kernel-mode driver files, including nncam.cat, nncam.inf and nncam.sys.
The x64 folder contains the x64 kernel-mode driver files, including nncam.cat, nncam.inf and nncam.sys.
- samples:
 1. democpp, C++ example. This example demonstrates enumerating devices, opening devices, previewing videos, capturing images, setting resolution, triggering, saving images to files in various image formats (.bmp, .jpg, .png, etc.), wmv format video recording, Trigger Mode, IO control and so on. This example uses the Pull Mode mechanism. To keep the code clean, the WTL library used by the examples can be downloaded from this link <http://sourceforge.net/projects/wtl/>.
 2. demopush, C++ example, using the Push Mode mechanism, StartPushModeV3.
 3. demomfc, a simple C++ example, uses MFC as a GUI library, supports opening devices, previewing videos, capturing images, setting resolution, saving images to files in various image formats (.bmp, .jpg, .png, etc.), etc. This example uses the Pull Mode mechanism.
 4. demowinformcs1, take C# winform for example, it supports opening devices, previewing videos, capturing images, saving images to files, and setting white balance. This example uses the Pull Mode mechanism, StartPullModeWithWndMsg.
 5. demowinformcs2, take C# winform for example, it supports opening devices, previewing videos, capturing images, saving images to files, and setting white balance. This example uses the Pull Mode mechanism, StartPullModeWithCallback.
 6. demowinformcs3, take C# winform for example, it supports opening devices, previewing videos, capturing images, saving images to files, and setting white balance. This example uses the Push Mode mechanism, StartPushMode.
 7. demowinformvb, take VB.NET winform for example, it supports opening devices, previewing videos, capturing images, saving images to files, and setting white balance. This example uses the Pull Mode mechanism.
- linux: Linux platform files
Udev: 99-nncam.rules, udev rule file.
Please refer to: http://reactivated.net/writing_udev_rules.html.
- #: nncam.cs, Support. Net Core C#. nncam.cs uses P/Invoke to call libnncam.so. Please copy nncam.cs to your C# project for use.
- x86: libnncam.so, x86 version so file.
- x64: libnncam.so, x64 version so file.
- armel: libnncam.so, armel version so file, toolchain is arm-linux-gnueabi.
- armhf: libnncam.so, armhf version so file, toolchain is arm-linux-gnueabi.

- arm64: libnncam.so, arm64 version so file, toolchain is aarch64-linux-gnu.
- android: libnncam.so for four architectures of Android platform arm, arm64, x86, x64.
- mac: macOS platform files.
- python: nncam.py and example code.
- java: nncam.java and example code (console and Swing).
- doc: SDK usage documentation, Simplified Chinese, English.
- sample:
 - de emosimplest, the simplest example, is about 60 lines of code.
 - demoraw, RAW data and still shots, about 120 lines of code.
- extras:
 - directshow: DirectShow SDK and demo program.
 - twain: TWAIN SDK.
 - labview: Labview SDK and demo program.
 - matlab: MatLab demo program.

EHD imaging GmbH, Zum Rennplatz 15, D-49401 Damme (Germany)
Tel: +49-5491-2090
email: info@ehdimaging.de
web: www.ehd.de

