



2026

EHD Vis-SWIR Series Camera User Manual



EHD imaging GmbH
18.05.2026

content

SWIR SERIES CAMERA USER MANUAL	1
1 PRODUCT DESCRIPTION AND FEATURES	7
2 CAMERA LIST	8
2.1 SWIR 400-1700 CAMERA MODEL PARAMETERS(31).....	8
2.2 SWIR 900-1700 CAMERA MODEL PARAMETERS(25).....	10
2.3 SWIR 400-2500 CAMERA MODEL SPECIFICATIONS(5).....	12
2.4 CQD 300-1700 CAMERA MODEL SPECIFICATIONS(4).....	13
3 SWIR 400-1700 CAMERA MODEL SPECIFICATIONS	14
3.1 SWIR 400-1700 5MP 3.45UM IMX992(9).....	14
3.1.1 <i>MaxCam-992TE-TR</i>	14
3.1.2 <i>MaxCam-992TE-TR-10G</i>	15
3.1.3 <i>MaxCam-992TE-TR-CXP</i>	16
3.1.4 <i>MaxCam-992TE-TR-CL100</i>	17
3.1.5 <i>MaxCam-992-TR-CXP</i>	18
3.1.6 <i>MaxCam-992-TR-10G</i>	19
3.1.7 <i>MaxCam-992-TR</i>	20
3.1.8 <i>SC992-TR-UMV</i>	21
3.1.9 <i>SC992-TR-GMV</i>	22
3.1.10 <i>IMX992 QE Curve</i>	23
3.1.11 <i>IMX992 Camera performance parameters</i>	23
3.2 SWIR 400-1700 3MP 3.45UM IMX993(7).....	24
3.2.1 <i>MaxCam-993TE-TR</i>	24
3.2.2 <i>MaxCam-993TE-TR-10G</i>	25
3.2.3 <i>MaxCam-993TE-TR</i>	26
3.2.4 <i>MaxCam-993TE-TR-CL150</i>	27
3.2.5 <i>MaxCam-993-TR</i>	29
3.2.6 <i>SC993-TR-UMV</i>	30
3.2.7 <i>SC993-TR-GMV</i>	31
3.2.8 <i>IMX993 QE Curve</i>	32
3.2.9 <i>IMX993 Camera performance parameters</i>	32
3.3 SWIR 400-1700 1.3MP 5UM IMX990(8).....	33
3.3.1 <i>MaxCam-990TE-TR</i>	33
3.3.2 <i>MaxCam-990TE-TR-G</i>	34
3.3.3 <i>MaxCam-990TE-TR-CXP</i>	35
3.3.4 <i>MaxCam-990TE-TR-CL180</i>	36
3.3.5 <i>MaxCam-990-TR</i>	37
3.3.6 <i>MaxCam-990-TR-G</i>	38
3.3.7 <i>SC990-TR-UMV</i>	39
3.3.8 <i>SC990-TR-GMV</i>	40
3.3.9 <i>IMX990 QE Curve</i>	41
3.3.10 <i>IMX990 Camera performance parameters</i>	41
3.4 SWIR 400-1700 0.33MP 5UM IMX991(8).....	42
3.4.1 <i>MaxCam-991TE-TR</i>	42
3.4.2 <i>MaxCam-991TE-TR-G</i>	43
3.4.3 <i>MaxCam-991TE-TR-CXP</i>	44
3.4.4 <i>MaxCam991-TE-TR-CL350</i>	45
3.4.5 <i>MaxCam991-TR</i>	46
3.4.6 <i>SC991-TR-WUH</i>	47

3.4.7	MaxCam-991-TR-G.....	48
3.4.8	SC991-TR-UMV.....	49
3.4.9	SC991-TR-GMV.....	50
3.4.10	IMX991 QE Curve.....	51
3.4.11	IMX991 Camera performance parameters.....	51
4	SWIR 900-1700 CAMERA MODEL SPECIFICATIONS.....	52
4.1	SWIR 900-1700 1.3MP 15um(6).....	52
4.1.1	EHD1302KMB-CXP.....	52
4.1.2	EHD1303KMB-G.....	53
4.1.3	EHD1303KMB-10G.....	54
4.1.4	EHD1302KMB-U200.....	55
4.1.5	EHD1302KMB-10G.....	56
4.1.6	EHD1302KMA-CL200 InGaAs sensor.....	57
4.1.7	EHD1302KMB-CL200.....	58
4.1.8	EHD1302 QE Curve.....	59
4.1.9	EHD1302 Frame rate and ROI frame rate.....	59
4.2	SWIR 900-1700 0.33MP 15UM INGAAS SENSOR (17).....	60
4.2.1	EHD339KMB-CL700.....	60
4.2.2	EHD339KMB-CL700-H.....	61
4.2.3	EHD331KMA-CL1000.....	62
4.2.4	EHD331KMA-CL700.....	63
4.2.5	EHD331KMA-CL500.....	64
4.2.6	EHD331KMB-CL1000.....	65
4.2.7	EHD331KMB-CL700.....	66
4.2.8	EHD331KMB-CL500.....	67
4.2.9	EHD331KMB-G125.....	68
4.2.10	EHD331KMB-G125-C0.....	69
4.2.11	EHD331KMB-G350.....	70
4.2.12	EHD331KMB-G700.....	71
4.2.13	EHD331KMB-10G.....	72
4.2.14	EHD331KMB-U700.....	73
4.2.15	EHD331KMB-U700-C0.....	74
4.2.16	EHD331KMB-UMV.....	75
4.2.17	EHD331KMB-GMV.....	76
4.2.18	EHD331 QE Curve.....	77
4.2.19	EHD331 Frame rate and ROI frame rate.....	77
4.3	SWIR 900-1700 LINE SCAN CAMERAS.....	79
4.3.1	EHD2048L3A-CL80K.....	79
4.3.2	EHD2048L3A-CL80K QE Curve.....	80
5	SWIR 400-2500 CAMERA MODEL SPECIFICATIONS.....	81
5.1	SWIR 400-1700 1.3MP 15um (1)	81
5.1.1	EHD1302KMB-E0417-U200.....	81
5.1.2	EHD1302KMB QE Curve.....	82
5.2	SWIR 400-1700 0.33MP 15um(2).....	83
5.2.1	EHD339KMB-E0417-CL700.....	83
5.2.2	EHD339KMB-E0417-U700.....	84
5.2.3	EHD339KMB-E0417 QE Curve.....	85
5.2.4	SWIR 1000-1900 0.33MP 15um(1).....	86
5.2.5	EHD333KMB-E1019-U240.....	86
5.2.6	EHD333KMB-E1019 QE Curve.....	87
5.3	SWIR 1200-2200 0.33MP 15um(1).....	88

5.3.1	EHD333KMB-E1222-U270.....	88
5.3.2	EHD333KMB-E1222-U270 QE Curve.....	89
6	CQD 300-1700 CAMERA MODEL SPECIFICATIONS.....	90
6.1	CQD 800-1700 0.33MP 15um(1).....	90
6.1.1	EHD334KMB-U110.....	90
6.2	CQD 400-1700 0.33MP 15um(2).....	91
6.2.1	EHD335KMB-U200.....	91
6.2.2	EHD334 QE Curve.....	92
6.2.3	EHD335KMB-UMV-U200 QE Curve.....	93
6.2.4	EHD335KMB-UMV.....	94
6.2.5	EHD335KMB-UMV QE Curve.....	95
6.3	CQD 300-1400 0.33MP 15um(1).....	96
6.3.1	EHD336KMB-UMV.....	96
6.3.2	EHD336KMB-UMV QE Curve.....	97
7	CAMERA FUNCTIONS AND FEATURES.....	98
7.1	10GIGE / 5GIGE / 2.5GIGE / GIGE CAMERA SPECIFICATION.....	98
7.2	CAMERALINK CAMERA SPECIFICATION.....	98
7.3	CAMERA OPERATION MODE.....	98
7.4	BIT DEPTH AND ROI CONTROL.....	98
7.5	BANDWIDTH AND PRECISE FRAME RATE CONTROL.....	98
7.5.1	Bandwidth.....	98
7.5.2	Precise frame rate control.....	98
7.6	DDR3 BUFFER.....	98
7.7	BINNING.....	98
7.8	DC12V POWER SUPPLY AND COOLING SYSTEM.....	99
7.9	CAMERA PERFORMANCE ANALYSIS.....	99
7.10	LENS DESIGN GUIDELINES.....	99
7.11	CRA CHARACTERISTICS.....	101
7.11.1	Measurement Method.....	101
7.12	FILTER.....	104
7.13	RG VERSION DESCRIPTION.....	104
8	CAMERA DIMENSIONS AND PORT.....	106
8.1	SWIR 400-1700CAMERA DIMENSIONS AND PORT.....	106
8.1.1	SWIR 400-1700 Camera dimensions.....	106
8.1.2	SWIR 400-1700 Camera port.....	110
8.2	SWIR 900-1700 CAMERA DIMENSIONS AND PORT.....	113
8.2.1	SWIR331 GigE/USB Camera dimensions.....	113
8.2.2	SWIR1302 Camera dimensions.....	114
8.2.3	SWIR 900-1700 Camera port.....	117
8.3	SWIR 400-2500 CAMERA DIMENSIONS AND PORT.....	120
8.3.1	SWIR 400-2500 Camera dimensions.....	120
8.3.2	SWIR 400-2500 Camera port.....	121
8.4	CQD 300-1700 CAMERA DIMENSIONS AND PORT.....	122
8.4.1	CQD 300-1700 Camera dimensions.....	122
8.4.2	CQD 300-1700 Camera port.....	123
9	PACKING LIST.....	124
9.1	SWIR 400-1700 CAMERA PACKING LIST.....	124
9.2	SWIR 900-1700 CAMERA PACKING LIST.....	129
9.3	SWIR 400-2500 CAMERA PACKING LIST.....	131

9.4	CQD 300-1700 CAMERA PACKING LIST.....	133
10	EXTERNAL IO CONNECTOR AND ELECTRICAL CHARACTERISTICS.....	135
10.1	SWIR 400-1700 CAMERA PIN SIGNAL.....	135
10.2	SWIR 900-1700 CAMERA PIN SIGNAL.....	135
10.3	SWIR 400-2500 CAMERA PIN SIGNAL.....	136
10.4	I/O ELECTRICAL CHARACTERISTICS.....	136
10.4.1	<i>Opto-isolated input circuit (line0).....</i>	<i>136</i>
10.4.2	<i>Opto-isolated output circuit (line1).....</i>	<i>137</i>
10.4.3	<i>Input and output I/O circuit (line2/line3).....</i>	<i>138</i>
11	EHDview APPLICATION.....	140
11.1	APPLICATION INSTALLATION.....	140
11.2	INTRODUCTION TO EHDview.....	140
11.2.1	<i>User interface design.....</i>	<i>140</i>
11.2.2	<i>Professional Camera Control Sidebar.....</i>	<i>141</i>
11.2.3	<i>Professional and practical image processing functions.....</i>	<i>141</i>
11.2.4	<i>Super compatibility.....</i>	<i>141</i>
11.2.5	<i>Basic hardware requirements.....</i>	<i>141</i>
11.3	TRIGGER MODE AND ITS CONFIGURATION.....	142
11.3.1	<i>Video mode and Trigger mode.....</i>	<i>142</i>
11.3.2	<i>Trigger Sources and their capture style.....</i>	<i>142</i>
11.3.3	<i>The trigger capture and IO Control configurations.....</i>	<i>144</i>
11.4	COOLING.....	148
11.5	SOFTWARE DEVELOPMENT INSTRUCTIONS.....	149
11.5.1	<i>SDK description.....</i>	<i>149</i>
11.5.2	<i>SDK support platform.....</i>	<i>149</i>
11.5.3	<i>Introduction to SDK content.....</i>	<i>149</i>
11.5.4	<i>Third-party interface software.....</i>	<i>151</i>
12	CAMERALINK CAMERA APPLICATION.....	152
12.1	CONNECTION TO THE CAMERALINK.....	152
12.2	SOFTWARE INSTALLATION.....	152
12.2.1	<i>Install SDK.....</i>	<i>152</i>
12.2.2	<i>Install options.....</i>	<i>152</i>
12.2.3	<i>Install the driver.....</i>	<i>153</i>
12.3	CONFIGURE THE DALSA CAPTURE CARD.....	153
12.3.1	<i>Serial port configuration.....</i>	<i>153</i>
12.3.2	<i>CameraLink mode configured.....</i>	<i>154</i>
12.3.3	<i>Configuring CameraLink Receiving.....</i>	<i>155</i>
12.3.4	<i>CameraLink Receiving the configuration content.....</i>	<i>156</i>
12.4	USING GENICAM.....	158
12.4.1	<i>Communication Settings.....</i>	<i>158</i>
12.5	DESCRIPTION OF GENICAM.....	159
12.5.1	<i>Device Information and control.....</i>	<i>160</i>
12.5.2	<i>Image Format Controls.....</i>	<i>160</i>
12.5.3	<i>TEC Ctrl.....</i>	<i>160</i>
12.5.4	<i>Trigger ctrl.....</i>	<i>161</i>
12.6	THE MAIN FEATURES OF CAMERA.....	161
12.7	CAMERA COMMANDS.....	162
12.7.1	<i>Basic Formats.....</i>	<i>162</i>
12.7.2	<i>Dedicated Part Format.....</i>	<i>163</i>
12.7.3	<i>Definition of each register.....</i>	<i>163</i>

12.7.4	<i>Camera instruction example</i>	165
12.8	CL SDK & CLVIEW APPLICATION.....	165
12.8.1	<i>CL SDK</i>	166
12.8.2	<i>CLView application</i>	166
12.8.3	<i>CLCtrl software</i>	167
13	EHD imaging GmbH INFORMATION	168

1 Product description and features

SWIR series is a USB3 / GigE / 10GigE / CameraLink interface short-wave infrared camera which adopts SONY or nationally produced InGaAs sensor. This camera has high quantum efficiency and high sensitivity, suitable for many common SWIR applications in different industrial segments.

- Semiconductor industry: Solar cell and chip inspection
- Agriculture: Spectral remote sensing applications by multi-rotor aircraft
- Recycling industry: Material sorting of plastics, waste and other materials
- Medical Imaging and Research: Hyperspectral and multispectral imaging
- Food industry: Quality inspection and classification
- Beverage industry: Liquid level detection in opaque containers
- Packing: Sealed inspection
- Glass industry: High temperature glass fluoroscopy defect detection
- Printing: Insight into hidden features
- Video surveillance: Visual enhancement (e.g. smoke perspective)
- Security: Detection of counterfeit goods, such as currency, wigs or skin

The basic features of SWIR series are as follows:

- The 400-1700nm version uses the SONY SenSWIR InGaAs sensor
- The 900-1700nm version uses the nationally produced InGaAs sensor
- The 400-2500nm version utilizes a domestically produced indium gallium arsenide (InGaAs) chip with wavelength extension.
- The 300-1700nm version employs a colloidal quantum dot (CQD) chip.
- The resolution covers 5MP-0.33MP
- Provide cooling version or uncooled version
- Precise temperature control, the temperature difference can reach 10-25 degrees Celsius
- Spectral response range: 400nm-1700nm/ 900-1700nm
- 15um /5um / 3.45um pixel size
- Global shutter
- USB3 / GigE / 10GigE / CameraLink / analog AV and other data interfaces
- Higher 14-bit ADC
- 4Gb memory
- Support external IO trigger control
- High framerate exceeding official parameters
- Support field update firmware
- Accept OEM custom development

2 Camera List

2.1 SWIR 400-1700 camera model parameters(31)

Model Number	Image Sensor	Pixel Size(μm)	Dynamic Range SNR	Data Interface	FPS/Resolution-8bit	Binning	Exposure Time Dimensions
5.0MPIMX992							
MaxCam-992TE-TR-CXP	5.0M/IMX992(M,GS) 1/1.4" (8.94x7.09) Built-in TEC	3.45x3.4 5	51.36dB 51.47dB	CoaXPress	131@2560x2048 252@1280x1024	1x1 1x1	15μs~60s
MaxCam-992TE-TR-10G	5.0M/IMX992(M,GS) 1/1.4" (8.94x7.09) Built-in TEC	3.45x3.4 5	51.5dB 48.5dB	10G	145@2560x2048 278@1280x1024	1x1 1x1	15μs~60s 80mm
MaxCam-992TE-TR-CL100	5.0M/IMX992(M,GS) 1/1.4" (8.94x7.09) Built-in TEC	3.45x3.4 5	51.5dB 48.5dB	CameraLink	100@2560x2048 322@1280x1024	1x1 1x1	15μs~60s 80mm
MaxCam-992TE-TR	5.0M/IMX992(M,GS) 1/1.4" (8.94x7.09) Built-in TEC	3.45x3.4 5	51.5dB 48.5dB	USB3	61.9@2560x2048 135.7@1280x1024	1x1 1x1	15μs~60s 80mm
MaxCam-992-TR-CXP	5.0M/IMX992(M,GS) 1/1.4" (8.94 × 7.09) Built-in TEC	3.45x3.4 5	51.36dB 48.45dB	CoaXPress	131@ 560×2048 252@1280×1024	1×1 1×1	15μs~60s 80mm
MaxCam-992-TR-10G	5.0M/IMX992(M,GS) 1/1.4" (8.94x7.09) External TEC	3.45x3.4 5	51.5dB 48.5dB	10G	145@2560x2048 278@1280x1024	1x1 1x1	8us~60s 80mm
MaxCam-992-TR	5.0M/IMX992(M,GS) 1/1.4" (8.94x7.09) External TEC	3.45x3.4 5	51.5dB 48.5dB	USB3	61.9@2560x2048 135.7@1280x1024	1x1 1x1	15us~60s 80mm
SC992-TR-UMV	5.0M/IMX992(M,GS) 1/1.4" (8.94x7.09) Without TEC	3.45x3.4 5	51.5dB 48.5dB	USB3	61.9@2560x2048 135.7@1280x1024	1x1 1x1	15μs~60s 33mm
SC992-TR-GMV	5.0M/IMX992-AABJ-C(M,GS) 1/1.4"(8.94x7.09) Without TEC	3.45x3.4 5	51.36dB 48.45dB	GigE	22fps@2560x2048(8bit) 11fps@2560x2048(12bit)	1x1 1x1	15μs~60s 58mm
3.0MPIMX993							
MaxCam-993TE-TR	3.0M/IMX993(M,GS) 1/1.8"(7.07×5.3) Built-in TEC	3.45×3.4 5	51.5dB 48.5dB	USB3	93@2048×1536 176@1024×768	1×1 1×1	15μs~60s 80mm
MaxCam-993TE-TR-10G	3.0M/IMX993(M,GS) 1/1.8"(7.07×5.3) Built-in TEC	3.45×3.4 5	51.5dB 48.5dB	10GigE	150@2048×1536 300@1024×768	1×1 1×1	15μs~60s 80mm
MaxCam-993TE-TR-CXP	3.0M/IMX993(M,GS) 1/1.8"(7.07×5.3) Built-in TEC	3.45×3.4 5	51.36dB 51.47dB	CoaXPress	173@2048×1536 328@1024×768	1×1 1×1	15μs~60s
MaxCam-993TE-TR-CL150	3.0M/IMX993(M,GS) 1/1.8"(7.07×5.3) Built-in TEC	3.45×3.4 5	51.5dB 48.5dB	CameraLink	150@2048×1536 300@1024×768	1×1 1×1	15μs~60s 80mm
MaxCam-993-TR	3.0M/IMX993(M,GS) 1/1.8"(7.07×5.3) External TEC	3.45×3.4 5	51.5dB 48.5dB	USB3	93@2048×1536 176@1024×768	1×1 1×1	15μs~60s 80mm
SC993-TR-UMV	3.0M/IMX993(M,GS) 1/1.8"(7.07×5.3) Without TEC	3.45×3.4 5	51.5dB 48.5dB	USB3	93@2048×1536 176@1024×768	1×1 1×1	15μs~60s 33mm
SC993-TR-GMV	3.0M/IMX993-AABJ-C(M,GS) 1/1.8"(7.07×5.30) Without TEC	3.45×3.4 5	51.36dB 48.45dB	GigE	37fps@2048×1536(8bit) 18.5fps@2048×1536(12bit)	1×1 1×1	15μs~60s 58mm
1.3MPIMX990							

SWIR 400-1700 camera model parameters

MaxCam-990TE-TR	1.3M/IMX990(M,GS) 1/2"(6.40×5.12) Built-in TEC	5×5	58.7dB 52.6dB	USB3	200@1280×1024 392@640×512	1×1 1×1	15μs~60s 80mm
MaxCam-990TE-TR -G	1.3M/IMX990(M,GS) 1/2"(6.40×5.12) Built-in TEC	5×5	58.7dB 52.6dB	GigE	90@1280×1024 253@640×512	1×1 1×1	15μs~60s 80mm
MaxCam-990TE-TR -CXP	0.33M/IMX991(M,G S) 1/4"(3.20×2.56) Built-in TEC	5×5	58.7dB	CoaXPress	200@1280×1024 392@640×512	1×1 1×1	15μs~60s
MaxCam-990TE-TR -CL180	1.3M/IMX990(M,GS) 1/2"(6.40×5.12) Built-in TEC	5×5	58.7dB 52.6dB	CameraLink	200@1280×1024 392@640×512	1×1 1×1	15μs~60s 80mm
MaxCam-990-TR	1.3M/IMX990(M,GS) 1/2"(6.40×5.12) External TEC	5×5	58.7dB 52.6dB	USB3	200@1280×1024 392@640×512	1×1 1×1	15μs~60s 80mm
MaxCam-990-TR -G	1.3M/IMX990(M,GS) 1/2"(6.40×5.12) External TEC	5×5	58.7dB 52.6dB	GigE	90@1280×1024 253@640×512	1×1 1×1	15μs~60s 80mm
SC990-TR-UMV	1.3M/IMX990(M,GS) 1/2"(6.40×5.12) Without TEC	5×5	58.7dB 52.6dB	USB3	223@1280×1024 428@640×512	1×1 1×1	15μs~60s 33mm
SC990-TR-GMV	1.3M/IMX990-AABJ- C(M,GS) 1/2"(6.40×5.12) Without TEC	5×5	58.7dB 52.4dB	GigE	90fps@1280×1024(8bit) 45fps@1280×1024(12bit)	1×1 1×1	15μs~60s 58mm
0.33MPIMX991							
MaxCam-991TE-TR	0.33M/IMX991(M,G S) 1/4"(3.20×2.56) Built-in TEC	5×5	58.7dB 52.6dB	USB3	400@640×512 753@320×256	1×1 1×1	15μs~60s 80mm
MaxCam-991TE-TR -G	0.33M/IMX991(M,G S) 1/4"(3.20×2.56) Built-in TEC	5×5	58.7dB 52.6dB	GigE	258.8@640×512 486.1@320×256	1×1 1×1	15μs~60s 80mm
MaxCam-991TE-TR -CXP	0.33M/IMX991 (InGaAs) 1/4"	5×5	59.7dB	CoaXPress	400@640×512 753@320×256	1×1 1×1	15μs~60s
MaxCam-991TE-TR -CL350	0.33M/IMX991(M,G S) 1/4"(3.20×2.56) Built-in TEC	5×5	58.7dB 52.6dB	CameraLink	350@640×512 753@320×256	1×1 1×1	15μs~60s 80mm
MaxCam-991-TR	0.33M/IMX991(M,G S) 1/4"(3.20×2.56) External TEC	5×5	58.7dB 52.6dB	USB3	400@640×512 753@320×256	1×1 1×1	15μs~60s 80mm
SC991-TR-WUH	0.33M/IMX991(M,G S) 1/4"(3.20×2.56)	5.0x5.0	59.6dB 52.5dB	HDMI1.4/WiFi/USB 2	137@640x512	1x1	0.04ms~1000m s 71.5mm
MaxCam-991-TR -G	0.33M/IMX991(M,G S) 1/4"(3.20×2.56) External TEC	5×5	58.7dB 52.6dB	GigE	258.8@640×512 486.1@320×256	1×1 1×1	15μs~60s 80mm
SC991-TR-UMV	0.33M/IMX991(M,G S) 1/4"(3.20×2.56) Without TEC	5×5	58.7dB 52.6dB	USB3	428.1@640×512 807@320×256	1×1 1×1	15μs~60s 33mm
SC991-TR-GMV	0.33M/IMX991- AABJ-C(M,GS) 1/4"(3.20×2.56) Without TEC	5×5	59.6dB 52.5dB	GigE	257.8fps@640×512(8bit) 137.1fps@640×512(12bit)	1×1 1×1	15μs~60s 58mm

* EHD1300KMB-UMV and EHD330KMB-UMV can provide RG (Removed Glass) versions, Please refer specifically to 7.13

2.2 SWIR 900-1700 camera model parameters(25)

Model Number	Image Sensor	Pixel Size(μm)	Dynamic Range SNR	Data Interface	FPS/Resolution-8bit	ADC Type	Exposure Time Dimensions
2048×1 Line Scan							
EHD2048L3A-CL80K	2048×1 25.6mm Built-in TEC	12.5×12.5	64.1dB 49.8dB	Camralink Full	79K@2048×1	ADC-B	1 μs ~1s 90.3mm
1.3MP1280×1024							
EHD1302KMA-CL200	1.3M/1280×1024 1.5" (19.2×15.36) Built-in TEC	15×15	69.2dB 65.4dB	CameraLink	200@1280×1024	ADC-A	16 μs ~1s 68mm
EHD1302KMB-CXP	1.3M/1280×1024 1.5" (19.2×15.36) Built-in TEC	15×15	69.2dB 65.4dB	CoaXPress	100@1280×1024	ADC-B	16 μs ~5s 68mm
EHD1302KMB-U200	1.3M/1280×1024 1.5" (19.2×15.36) Built-in TEC	15×15	69.2dB 65.4dB	USB3	200@1280×1024	ADC-B	16 μs ~1s 68mm
EHD1302KMB-10G	1.3M/1280×1024 1.5" (19.2×15.36) Built-in TEC	15×15	69.2dB 65.4dB	10GigE	200@1280×1024	ADC-B	16 μs ~1s 68mm
EHD1302KMB-CL200	1.3M/1280×1024 1.5" (19.2×15.36) Built-in TEC	15×15	69.2dB 65.4dB	CameraLink	200@1280×1024	ADC-B	16 μs ~1s 68mm
EHD1303KMB-10G	1.3M/1280×1024 1.5" InGaAs Built-in TEC	15×15	71.5dB 63.1dB	10Gig E	100@1280×1024	ADC-B	16 μs ~ 5 s 68 mm
EHD1303KMB-G	1.3M/1280×1024 1.5" (19.2×15.36) Built-in TEC	15×15	71.5dB 63.1dB	GigE	87@1280×1024	ADC-B	16 μs ~5s 68mm
0.33MP640×512							
EHD331KMA-CL500	0.33M/640×512 3/4" (9.60×7.68) Built-in TEC	15×15	70.6dB 63.0dB	CameraLink	517@640×512	ADC-A	16 μs ~1s 68mm
EHD331KMA-CL700	0.33M/640×512 3/4" (9.60×7.68) Built-in TEC	15×15	70.6dB 63.0dB	CameraLink	724@640×512	ADC-A	16 μs ~1s 68mm
EHD331KMA-CL1000	0.33M/640×512 3/4" (9.60×7.68) Built-in TEC	15×15	70.6dB 63.0dB	CameraLink	1000@640×512	ADC-A	16 μs ~1s 68mm
EHD331KMB-U700	0.33M/640×512 3/4" (9.60×7.68) Built-in TEC	15×15	70.6dB 63.0dB	USB3	724@640×512	ADC-B	16 μs ~5s 68mm
EHD331KMB-U700-C0	0.33M/640×512 3/4" (9.60×7.68) Built-in TEC	15×15	70.6dB 63.0dB	USB3	724@640×512	ADC-B	16 μs ~5s 68mm
EHD331KMB-G125	0.33M/640×512 3/4" (9.60×7.68) Built-in TEC	15×15	70.6dB 63.0dB	GigE	125@640×512	ADC-B	25 μs ~5s 68mm
EHD331KMB-G125-C0	0.33M/640×512 3/4" (9.60×7.68) Built-in TEC	15×15	70.6dB 63.0dB	GigE	125@640×512	ADC-B	25 μs ~5s 68mm
EHD331KMB-G350	0.33M/640×512 3/4" (9.60×7.68) Built-in TEC	15×15	70.6dB 63.0dB	GigE	360@640×512	ADC-B	25 μs ~5s 68mm
EHD331KMB-G700	0.33M/640×512 3/4" (9.60×7.68) Built-in TEC	15×15	70.6dB 63.0dB	GigE	360@640×512 700@320×256	ADC-B	25 μs ~5s 68mm

SWIR 400-2500 camera model specifications

EHD331KMB-10G	0.33M/640×512 3/4" (9.60×7.68) Built-in TEC	15×15	70.6dB 63.0dB	10GigE	724@640×512	ADC-B	25μs~5s 68mm
EHD331KMB-CL500	0.33M/640×512 3/4" (9.60×7.68) Built-in TEC	15×15	70.6dB 63.0dB	CameraLink	517@640×512	ADC-B	16μs~1s 68mm
EHD331KMB-CL700	0.33M/640×512 3/4" (9.60×7.68) Built-in TEC	15×15	70.6dB 63.0dB	CameraLink	724@640×512	ADC-B	16μs~1s 68mm
EHD331KMB-UMV	0.33M/640×512 3/4" (9.60×7.68) Built-in TEC	15×15	70.6dB 63.0dB	USB3	400@640×512	ADC-B	16μs~5s 45mm
EHD331KMB-GMV	0.33M/(640×512) 3/4"(9.60×7.68) Built-in TEC	15×15	70.59dB 62.98dB	GigE	350fps@640x512(8bit) 180fps@640x512(14bit)	ADC-B	16μs~5s 46.7mm
EHD339KMB-CL700	0.33M/640×512 3/4" (9.60×7.68) Built-in TEC	15×15	70.6dB 63.0dB	CameraLink	724@640×512	ADC-B	16μs~1s 68mm
EHD339KMB-CL700-H	0.33M/640×512 3/4" (9.60×7.68) Built-in TEC	15×15	78.4dB 70.0dB	CameraLink	724@640×512(16bit)	ADC-B	16μs~1s 68mm

* -H: 16-bit ADC.

* Frame rate of EHD331KMB-G700 is limited by network interface and can only reach 360fps at full resolution. Frame rate can be improved through ROI.

* Note: ADC-A/ADC-B indicate approved hardware variants. Imaging performance specifications remain the same unless otherwise stated.

2.3 SWIR 400-2500 camera model specifications(5)

Model Number	Image Sensor	Pixel Size(μm)	Dynamic Range SNR	Data Interface	FPS/Resolution-8bit	Wavelength (nm)
15μm, 1280\times1024, 400-1700nm						
EHD1302KMB-E0417-U200	1.3M/1280x1024 1.5" (19.2x15.36) Built-in TEC	15 \times 15	70.59dB 62.98dB	USB3	200@1280x1024	400-1700
15μm, 640\times512, 400-1700nm						
EHD339KMB-E0417-CL700	0.33 M / 640 \times 512 3/4" (9.60 \times 7.68) Built-in TEC	15 \times 15	72.9 dB 63.3 dB	CameraLink	724@640 \times 512	400-1700
EHD339KMB-E0417-U700	0.33 M / 640 \times 512 3/4" (9.60 \times 7.68) Built-in TEC	15 \times 15	72.9 dB 63.3 dB	USB3	724@640 \times 512	400-1700
15μm, 640\times512, 1000-1900nm						
EHD333KMB-E1019-U240	0.33 M / 640 \times 512 3/4" (9.60 \times 7.68) Built-in TEC	15 \times 15	TBD	USB3	240 @ 640 \times 512	1000-1900
15μm, 640\times512, 1200-2200nm						
EHD333KMB-E1222-U240	0.33 M / 640 \times 512 3/4" (9.60 \times 7.68) Built-in TEC	15 \times 15	71.4 dB 60.8 dB	USB3	270 @ 640 \times 512	1200-2200

2.4 CQD 300-1700 camera model specifications(4)

Model Number	Image Sensor	Pixel Size(μm)	Dynamic Range SNR	Data Interface	FPS/Resolution-8bit	Wavelength (nm)
15μm, 640\times512, 800-1700nm						
EHD334KMB-U110	0.33 M / 640 \times 512 3/4" (9.60 \times 7.68) Built-in TEC	15 \times 15	75dB 60dB	USB3	110 @ 640 \times 512	800-1700
15μm, 640\times512, 400-1700nm						
EHD335KMB-U200	0.33 M / 640 \times 512 3/4" (9.60 \times 7.68) Built-in TEC	15 \times 15	TBD	USB3	200 @ 640 \times 512	400-1700
EHD335KMB-UMV	0.33 M / 640 \times 512 3/4" (9.60 \times 7.68) Built-in TEC	15 \times 15	TBD	USB3	200 @ 640 \times 512	400-1700
15μm, 640\times512, 300-1400nm						
EHD336KMB-UMV	0.33 M / 640 \times 512 3/4" (9.60 \times 7.68)	15 \times 15	66dB 61.4dB	USB3	400 @ 640 \times 512	300-1400

3 SWIR 400-1700 camera model specifications

3.1 SWIR 400-1700 5MP 3.45um IMX992(9)

3.1.1 MaxCam-992TE-TR

Table 3-1 MaxCam-992TE-TR camera specifications

Parameter	Model
	SWIR5000KMA 5.0M pixels 1/1.4" CMOS USB3.0 industrial camera
Camera Parameters	
Sensor model	Sony IMX992-AABA-C
Sensor Type	InGaAs
Spectral Range	400nm-1700nm
Pixel size	3.45 μm x 3.45 μm
Sensor size	1/1.4"
ADC	12 Bit / 8 Bit
Frame rate	8 Bit:61.9fps@2560×2048 / 135.7fps@1280×1024 12 Bit:35.5fps@2560×2048 / 135.7fps@1280×1024
Image Buffer	512MByte
Conversion Gain	10.3e/ADU (HCG) 17.29e/ADU (LCG)
Dynamic range	51.36dB (HCG) 51.47dB (LCG)
Readout Noise	111.88e (HCG) 186.61e (LCG)
Full Well	41.39ke (HCG) 69.92ke (LCG)
SNRmax	46.17dB (HCG) 48.45dB (LCG)
Sensitivity	TBD
Dark current	TBD
Gain range	1x-15x
Exposure time	15μs-60sec
Shutter	Global shutter
Binning	Software 2×2, 3×3, 4×4
Data interface	USB3.0
Digital I/O	One optical-coupling isolated input, one optical-coupling isolated output, two non-isolated input and output
Data Format	8bit / 12bit
Cooling performance	25°C below ambient temperature
Optical filter	400-1800nm(default); 1030-1800nm(optional)
CRA	2.35 Deg
General specification	
Power supply	Power with USB3.0 or 12V Power adapter
Power consumption	<2.1W(without cooling) / <25W(cooling)
Temperature	Working temperature -20~60°C, storage temperature -40~85°C
Humidity	20%-80%, no condensation
Size	80mm×80mm×45.5mm
Weight	<390g
Lens mount	C-mount
Software	EHDview/ SDK
Operating system	Win32/WinRT/Linux/macOS/Android
Certification	CE, FCC

3.1.2 MaxCam-992TE-TR-10G

Table 3-2 MaxCam-992TE-TR-10G camera specifications

Parameter	Model
	SWIR5000KMA-10G 5.0Mpixels 1/1.4" CMOS10G Industrial camera
Camera Parameters	
Sensor model	Sony IMX992-AABA-C
Sensor Type	InGaAs
Spectral Range	400nm-1700nm
Pixel size	3.45 μm x 3.45 μm
Sensor size	1/1.4"
ADC	12 Bit / 10 Bit / 8 Bit
Frame rate	8 Bit:145fps@2560×2048 / 278fps@1280×1024 10 Bit:145fps@2560×2048 / 278fps@1280×1024 12 Bit:82.7fps@2560×2048 / 158.6fps@1280×1024
Image Buffer	512MByte
Conversion Gain	10.3e/ADU (HCG) 17.29e/ADU (LCG)
Dynamic range	51.36dB (HCG) 51.47dB (LCG)
Readout Noise	111.88e (HCG) 186.61e (LCG)
Full Well	41.39ke (HCG) 69.92ke (LCG)
SNRmax	46.17dB (HCG) 48.45dB (LCG)
Sensitivity	TBD
Dark current	TBD
Gain range	1x-15x
Exposure time	15μs-60sec
Shutter	Global shutter
Binning	Software 2×2, 3×3, 4×4
Data interface	10G
Digital I/O	One optical-coupling isolated input, one optical-coupling isolated output, two non-isolated input and output
Data Format	8bit / 12bit
Cooling performance	25°C below ambient temperature
Optical filter	400-1800nm(default); 1030-1800nm(optional)
CRA	2.35 Deg
General specification	
Power supply	12V Power adapter
Power consumption	TBD
Temperature	Working temperature -20~60°C, storage temperature -40~85°C
Humidity	20%-80%, no condensation
Size	80mm×80mm×45.5mm
Weight	<390g
Lens mount	C-mount
Software	EHDview/ SDK
Operating system	Win32/WinRT/Linux/macOS/Android
Certification	CE, FCC

3.1.3 MaxCam-992TE-TR-CXP

Table 3-3 MaxCam-992TE-TR-CXP camera specifications

Parameter	Model
	SWIR5000KMA-CXP 5.0M pixels 1/1.4" CMOS CoaXPress industrial camera
Camera Parameters	
Sensor model	Sony IMX992-AABA-C
Sensor Type	InGaAs
Spectral Range	400nm-1700nm
Pixel size	3.45 μm x 3.45 μm
Sensor size	1/1.4"
ADC	12 Bit / 10 Bit / 8 Bit
Frame rate	8 Bit:131fps@2560×2048 / 252fps@1280×1024 10 Bit:120fps@2560×2048 / 231fps@1280×1024 12 Bit:70fps@2560×2048 / 135fps@1280×1024
Image Buffer	512MByte
Conversion Gain	10.3e/ADU (HCG) 17.29e/ADU (LCG)
Dynamic range	51.3dB (HCG) 51.36dB (LCG)
Readout Noise	111.88e (HCG) 186.61e (LCG)
Full Well	41.39ke (HCG) 69.92ke (LCG)
SNRmax	46.17dB (HCG) 51.4dB (LCG)
Sensitivity	TBD
Dark current	TBD
Gain range	1x-15x
Exposure time	15 μs -60sec
Shutter	Global shutter
Binning	Software 2×2, 3×3, 4×4
Data interface	CoaXPress 2.0 (CXP-10 x 1)
Digital I/O	One optical-coupling isolated input, one optical-coupling isolated output, two non-isolated input and output
Data Format	8bit / 12bit
Cooling performance	25°C below ambient temperature
Optical filter	400-1800nm(default); 1030-1800nm(optional)
CRA	2.35 Deg
General specification	
Power supply	12V Power adapter
Power consumption	<2.1W(without cooling) / <25W(cooling)
Temperature	Working temperature -20~60°C, storage temperature -40~85°C
Humidity	20%-80%, no condensation
Size	80mm×80mm×45.5mm
Weight	<390g
Lens mount	C-mount
Software	EHDview/ SDK
Operating system	Win32/WinRT/Linux/macOS/Android
Certification	CE, FCC

3.1.4 MaxCam-992TE-TR-CL100

Table 3-4 MaxCam-992TE-TR-CL100 camera specifications

Parameter	Model	SWIR5000KMA-CL100
		5.0Mpixels 1/1.4" CMOS CameraLink industrial camera
Camera Parameters		
Sensor model		Sony IMX992-AABA-C
Sensor Type		InGaAs
Spectral Range		400nm-1700nm
Pixel size		3.45 μm x 3.45 μm
Sensor size		1/1.4"
ADC		12 Bit / 10 Bit
Frame rate		10 Bit:100fps@2560×2048 / 322fps@1280×1024 12 Bit:61fps@2560×2048 / 187fps@1280×1024
Image Buffer		512MByte
Conversion Gain		10.3e/ADU (HCG) 17.29e/ADU (LCG)
Dynamic range		51.36dB (HCG) 51.47dB (LCG)
Readout Noise		111.88e (HCG) 186.61e (LCG)
Full Well		41.39ke (HCG) 69.92ke (LCG)
SNRmax		46.17dB (HCG) 48.45dB (LCG)
Sensitivity		TBD
Dark current		TBD
Gain range		1x-15x
Exposure time		15μs-60sec
Shutter		Global shutter
Binning		Nonsupport
Data interface		CameraLink
Digital I/O		One optical-coupling isolated input, one optical-coupling isolated output, two non-isolated input and output
Data Format		10bit / 12bit
Cooling performance		25°C below ambient temperature
Optical filter		400-1800nm(default); 1030-1800nm(optional)
CRA		2.35 Deg
General specification		
Power supply		12V Power adapter
Power consumption		TBD
Temperature		Working temperature -20~60°C, storage temperature -40~85°C
Humidity		20%-80%, no condensation
Size		75mm×75mm×81.9mm
Weight		<390g
Lens mount		C-mount
Software		EHDview/ SDK
Operating system		Win32/WinRT/Linux/macOS/Android
Certification		CE, FCC

3.1.5 MaxCam-992TE-TR-CXP

Table 3-5 MaxCam-992TE-TR-CXP camera specifications

Parameter	Model	SWIR500KMA-CXP 5.0M pixels 1/1.4" CMOS CoaXPress industrial camera
Camera Parameters		
Sensor model	Sony IMX992-AABJ-C	
Sensor Type	InGaAs	
Spectral Range	400nm-1700nm	
Pixel size	3.45 μm x 3.45 μm	
Sensor size	1/1.4"	
ADC	12 Bit / 8 Bit	
Frame rate	8 Bit: 131fps@2560x2048 / 252fps@1280x1024 10 Bit: 120fps@2560x2048 / 231fps@1280x1024 12 Bit: 70fps@2560x2048 / 135fps@1280x1024	
Image Buffer	512MByte	
Conversion Gain	10.3e/ADU (HCG) 17.29e/ADU (LCG)	
Dynamic range	51.3dB (HCG) 51.36dB (LCG)	
Readout Noise	111.88e (HCG) 186.61e (LCG)	
Full Well	41.39ke (HCG) 69.92ke (LCG)	
SNRmax	46.17dB (HCG) 48.45dB (LCG)	
Sensitivity	TBD	
Dark current	TBD	
Gain range	1x-15x	
Exposure time	8 μs – 60 s	
Shutter	Global shutter	
Binning	Software 2 \times 2, 3 \times 3, 4 \times 4	
Data interface	CoaXPress 2.0 (CXP-10 x 1)	
Digital I/O	One optical-coupling isolated input, one optical-coupling isolated output, two non-isolated input/output	
Data Format	8 Bit / 12 Bit	
Cooling performance	10 $^{\circ}\text{C}$ below ambient temperature	
Optical filter	400–1800 nm (default); 1030–1800 nm (optional)	
CRA	2.35 Deg	
General specification		
Power supply	Power over CoaXPress (PoCXP) / 12V Power Adapter	
Power consumption	<2.1W(without cooling) / <25W(cooling)	
Temperature	Working temperature -20~60 $^{\circ}\text{C}$, storage temperature -40~85 $^{\circ}\text{C}$	
Humidity	20%-80%, no condensation	
Size	80mm \times 80mm \times 45.5mm	
Weight	<390g	
Lens mount	C-mount	
Software	EHDview/ SDK	
Operating system	Win32/WinRT/Linux/macOS/Android	
Certification	CE, FCC	

3.1.6 MaxCam-992-TR-10G

Table 3-6 MaxCam-992-TR-10G camera specifications

Parameter	Model	SWIR5000kMA-10G
		5.0M pixels 1/1.4" CMOS USB3.0 industrial camera
Camera Parameters		
Sensor model		Sony IMX992-AABJ-C
Sensor Type		InGaAs
Spectral Range		400 nm – 1700 nm
Pixel size		3.45 μm \times 3.45 μm
Sensor size		1/1.4"
ADC		12 Bit / 10 Bit / 8 Bit
Frame rate		8 Bit: 145 fps @ 2560 \times 2048, 278 fps @ 1280 \times 1024 10 Bit: 145 fps @ 2560 \times 2048, 278 fps @ 1280 \times 1024 12 Bit: 82.7 fps @ 2560 \times 2048, 158.6 fps @ 1280 \times 1024
Image Buffer		2048 MByte
Conversion Gain		10.3 e ⁻ /ADU (HCG), 17.29 e ⁻ /ADU (LCG)
Dynamic range		51.36 dB (HCG), 51.47 dB (LCG)
Readout Noise		111.88 e ⁻ (HCG), 186.61 e ⁻ (LCG)
Full Well		41.39 ke ⁻ (HCG), 69.92 ke ⁻ (LCG)
SNRmax		46.17 dB (HCG), 48.45 dB (LCG)
Sensitivity		TBD
Dark current		TBD
Gain range		1 \times – 15 \times
Exposure time		8 μs – 60 s
Shutter		Global shutter
Binning		Software 2 \times 2, 3 \times 3, 4 \times 4
Data interface		10 GigE
Digital I/O		One optical-coupling isolated input, one optical-coupling isolated output, two non-isolated input/output
Data Format		8 Bit / 10 Bit / 12 Bit
Cooling performance		10 $^{\circ}\text{C}$ below ambient temperature
Optical filter		400–1800 nm (default); 1030–1800 nm (optional)
CRA		2.35 Deg
General specification		
Power supply		Power with USB3.0 or 12V Power adapter
Power consumption		<2.1W(without cooling) / <25W(cooling)
Temperature		Working temperature -20~60 $^{\circ}\text{C}$, storage temperature -40~85 $^{\circ}\text{C}$
Humidity		20%-80%, no condensation
Size		80mm \times 80mm \times 45.5mm
Weight		<390g
Lens mount		C-mount
Software		EHDview/ SDK
Operating system		Win32/WinRT/Linux/macOS/Android
Certification		CE, FCC

3.1.7 MaxCam-992-TR

Table 3-7 MaxCam-992-TR camera specifications

Parameter	Model
	SWIR5000KMB
5.0M pixels 1/1.4" CMOS USB3.0 industrial camera	
Camera Parameters	
Sensor model	Sony IMX992-AABJ-C
Sensor Type	InGaAs
Spectral Range	400nm-1700nm
Pixel size	3.45 μm x 3.45 μm
Sensor size	1/1.4"
ADC	12 Bit / 8 Bit
Frame rate	8 Bit:61.9fps@2560×2048 / 135.7fps@1280×1024 12 Bit:35.5fps@2560×2048 / 135.7fps@1280×1024
Image Buffer	512MByte
Conversion Gain	10.3e/ADU (HCG) 17.29e/ADU (LCG)
Dynamic range	51.36dB (HCG) 51.47dB (LCG)
Readout Noise	111.88e (HCG) 186.61e (LCG)
Full Well	41.39ke (HCG) 69.92ke (LCG)
SNRmax	46.17dB (HCG) 48.45dB (LCG)
Sensitivity	TBD
Dark current	TBD
Gain range	1x-15x
Exposure time	15μs-60sec
Shutter	Global shutter
Binning	Software2×2, 3×3, 4×4
Data interface	USB3
Digital I/O	One optical-coupling isolated input, one optical-coupling isolated output, two non-isolated input and output
Data Format	8bit / 12bit
Cooling performance	10°C below ambient temperature
Optical filter	400-1800nm(default); 1030-1800nm(optional)
CRA	2.35 Deg
General specification	
Power supply	Power with USB3.0 or 12V Power adapter
Power consumption	<2.1W(without cooling) / <25W(cooling)
Temperature	Working temperature -20~60°C, storage temperature -40~85°C
Humidity	20%-80%, no condensation
Size	80mm×80mm×45.5mm
Weight	<390g
Lens mount	C-mount
Software	EHDview/ SDK
Operating system	Win32/WinRT/Linux/macOS/Android
Certification	CE, FCC

3.1.8 SC992-TR-UMV

Table 3-8 SC992-TR-UMV camera specifications

Parameter	Model	SWIR5000KMB-UMV
		5.0M pixels 1/1.4" CMOS USB3.0 industrial camera
Camera Parameters		
Sensor model		Sony IMX992-AABJ-C
Sensor Type		InGaAs
Spectral Range		400nm-1700nm
Pixel size		3.45 μm x 3.45 μm
Sensor size		1/1.4"
ADC		12 Bit / 8 Bit
Frame rate		8 Bit:61.9fps@2560×2048 / 135.7fps@1280×1024 12 Bit:35.5fps@2560×2048 / 135.7fps@1280×1024
Image Buffer		512MByte
Conversion Gain		10.3e/ADU (HCG) 17.29e/ADU (LCG)
Dynamic range		51.36dB (HCG) 51.47dB (LCG)
Readout Noise		111.88e (HCG) 186.61e (LCG)
Full Well		41.39ke (HCG) 69.92ke (LCG)
SNRmax		46.17dB (HCG) 48.45dB (LCG)
Sensitivity		TBD
Dark current		TBD
Gain range		1x-15x
Exposure time		15μs-60sec
Shutter		Global shutter
Binning		Software 2×2, 3×3, 4×4
Data interface		USB3
Digital I/O		One optical-coupling isolated input, one optical-coupling isolated output, one non-isolated input and output
Data Format		8bit / 12bit
Optical filter		400-1800nm(default); 1030-1800nm(optional)
CRA		2.35 Deg
General specification		
Power supply		Power with USB3.0
Power consumption		<2.11W
Temperature		Working temperature -20~60°C, storage temperature -40~85°C
Humidity		20%-80%, no condensation
Size		33mm×33mm×38mm
Weight		70g
Lens mount		C-mount
Software		EHDview/ SDK
Operating system		Win32/WinRT/Linux/macOS/Android
Certification		CE, FCC

3.1.9 SC992-TR-GMV

Table 3-9 SC992-TR-GMV camera specifications

Parameter	Model
	SWIR5000KMB-GMV 5.0Mpixels 1/1.4" CMOS GigE industrial camera
Camera Parameters	
Sensor model	Sony IMX992-AABJ-C
Sensor Type	InGaAs
Spectral Range	400nm-1700nm
Pixel size	3.45 μm x 3.45 μm
Sensor size	1/1.4"
ADC	12 Bit / 8 Bit
Frame rate	8 Bit:22fps@2560×2048 / 90fps@1280×1024 12 Bit:11fps@2560×2048 / 45fps@1280×1024
Image Buffer	512MByte
Conversion Gain	10.3e/ADU (HCG) 17.29e/ADU (LCG)
Dynamic range	51.36dB (HCG) 51.47dB (LCG)
Readout Noise	111.88e (HCG) 186.61e (LCG)
Full Well	41.39ke (HCG) 69.92ke (LCG)
SNRmax	46.17dB (HCG) 48.45dB (LCG)
Sensitivity	TBD
Dark current	TBD
Gain range	1x-15x
Exposure time	15μs-60sec
Shutter	Global shutter
Binning	Software 2×2, 3×3, 4×4
Data interface	GigE
Digital I/O	One optical-coupling isolated input, one optical-coupling isolated output, two non-isolated input and output
Data Format	8bit / 12bit
Optical filter	400-1800nm(default); 1030-1800nm(optional)
CRA	2.35 Deg
General specification	
Power supply	12V Power adapter
Power consumption	<2.11W
Temperature	Working temperature -20~60°C, storage temperature -40~85°C
Humidity	20%-80%, no condensation
Size	33mm×33mm×58mm
Weight	TBD
Lens mount	C-mount
Software	EHDview/ SDK
Operating system	Win32/WinRT/Linux/macOS/Android
Certification	CE, FCC

3.1.10 IMX992 QE Curve

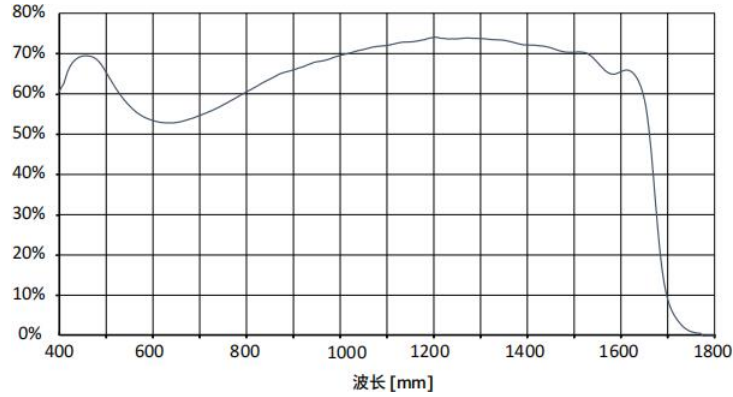

Figure 3-1 IM992 absolute quantum efficiency

3.1.11 IMX992 Camera performance parameters

The performance parameters of the camera are as follows:

- Maximum Resolution
- RAW 12 Bit mode
- Temperature: 5°C
- HCG

Table 3-10 MaxCam-992TE-TR Camera performance parameters

Gain Value	100	141	199	282	398	562	794	1500
e-/ADU	10.30	7.10	4.90	3.40	2.38	1.65	1.18	0.66
Read Noise (e-)	111.88	106.44	103.46	100.22	98.45	95.73	95.01	100.87
Full Well (ke-)	41.39	28.46	19.56	13.46	9.35	6.424	4.50	2.38
DR (dB)	51.3	48.5	45.5	42.5	39.5	36.5	33.5	27.4

Table 3-11 MaxCam-992-TR Camera performance parameters

Gain Value	100	141	199	282	398	562	794	1500
e-/ADU	10.44	7.16	4.92	3.42	2.35	1.64	1.14	0.53
Read Noise (e-)	115.65	111.15	107.79	105.44	101.89	99.56	95.78	82.89
Full Well (ke-)	41.53	28.44	19.48	13.50	9.23	6.39	4.37	1.94
DR (stop)	51.1	48.2	45.1	42.1	39.1	36.1	33.2	27.4

3.2 SWIR 400-1700 3MP 3.45um IMX993(7)

3.2.1 MaxCam-993TE-TR

Table 3-12 MaxCam-993TE-TR camera specifications

Parameter	Model
	SWIR3000KMA 3.0M pixels 1/1.8" CMOS USB3 industrial camera
Camera Parameters	
Sensor model	Sony IMX993-AABA-C
Sensor Type	InGaAs
Spectral Range	400nm-1700nm
Pixel size	3.45 μm x 3.45 μm
Sensor size	1/1.8"
ADC	12 Bit / 8 Bit
Frame rate	8 Bit:93fps@2048×1536 / 176fps@1024×768 12 Bit:57fps@2048×1536 / 176fps@1024×768
Image Buffer	512MByte
Conversion Gain	10.3e/ADU (HCG) 17.29e/ADU (LCG)
Dynamic range	51.36dB (HCG) 51.47dB (LCG)
Readout Noise	111.88e (HCG) 186.61e (LCG)
Full Well	41.39ke (HCG) 69.92ke (LCG)
SNRmax	46.17dB (HCG) 48.45dB (LCG)
Sensitivity	TBD
Dark current	TBD
Gain range	1x-15x
Exposure time	15 μs -60sec
Shutter	Global shutter
Binning	Software 2×2, 3×3, 4×4
Data interface	USB3
Digital I/O	One optical-coupling isolated input, one optical-coupling isolated output, two non-isolated input and output
Data Format	8bit / 12bit
Cooling performance	25°C below ambient temperature
Optical filter	400-1800nm(default); 1030-1800nm(optional)
CRA	2.35 Deg
General specification	
Power supply	Power with USB3.0 or 12V Power adapter
Power consumption	<2.1W(without cooling) / <25W(cooling)
Temperature	Working temperature -20~60°C, storage temperature -40~85°C
Humidity	20%-80%, no condensation
Size	80mm×80mm×45.5mm
Weight	<390g
Lens mount	C-mount
Software	EHDview/ SDK
Operating system	Win32/WinRT/Linux/macOS/Android
Certification	CE, FCC

3.2.2 MaxCam-993TE-TR-10G

Table 3-13 MaxCam-993TE-TR-10G camera specifications

Parameter	Model
	SWIR3000kMA-10G
3.0Mpixels 1/1.8" CMOS 10GigE industrial camera	
Camera Parameters	
Sensor model	Sony IMX993-AABA-C
Sensor Type	InGaAs
Spectral Range	400nm-1700nm
Pixel size	3.45 μm x 3.45 μm
Sensor size	1/1.8"
ADC	12 Bit / 10 Bit / 8 Bit
Frame rate	8 Bit:220fps@2048×1536 / 415fps@1024×768 10 Bit:200fps@2048×1536 / 380fps@1024×768 12 Bit:118fps@2048×1536 / 220fps@1024×768
Image Buffer	512MByte
Conversion Gain	10.3e/ADU (HCG) 17.29e/ADU (LCG)
Dynamic range	51.36dB (HCG) 51.47dB (LCG)
Readout Noise	111.88e (HCG) 186.61e (LCG)
Full Well	41.39ke (HCG) 69.92ke (LCG)
SNRmax	46.17dB (HCG) 48.45dB (LCG)
Sensitivity	TBD
Dark current	TBD
Gain range	1x-15x
Exposure time	15μs-60sec
Shutter	Global shutter
Binning	Software 2×2, 3×3, 4×4
Data interface	10G
Digital I/O	One optical-coupling isolated input, one optical-coupling isolated output, two non-isolated input and output
Data Format	8bit / 12bit
Cooling performance	10°C below ambient temperature
Optical filter	400-1800nm(default); 1030-1800nm(optional)
CRA	2.35 Deg
General specification	
Power supply	12V Power adapter
Power consumption	TBD
Temperature	Working temperature -20~60°C, storage temperature -40~85°C
Humidity	20%-80%, no condensation
Size	80mm×80mm×45.5mm
Weight	<390g
Lens mount	C-mount
Software	EHDview/ SDK
Operating system	Win32/WinRT/Linux/macOS/Android
Certification	CE, FCC

3.2.3 MaxCam-993TE-TR-CXP

Table 3-14 MaxCam-993TE-TR-CXP camera specifications

Parameter	Model	SWIR3000KMA-CXP
3.0M pixels 1/1.8" CMOS CoaXPress industrial camera		
Camera Parameters		
Sensor model		Sony IMX993-AABA-C
Sensor Type		InGaAs
Spectral Range		400nm-1700nm
Pixel size		3.45 μm x 3.45 μm
Sensor size		1/1.8"
ADC		12 Bit / 10 Bit / 8 Bit
Frame rate		8 Bit:173fps@2048×1536 / 328fps@1024×768 10 Bit:158fps@2048×1536 / 300fps@1024×768 12 Bit:93fps@2048×1536 / 176fps@1024×768
Image Buffer		512MByte
Conversion Gain		10.3e/ADU (HCG) 17.29e/ADU (LCG)
Dynamic range		51.36dB (HCG) 51.36dB (LCG)
Readout Noise		111.88e (HCG) 186.61e (LCG)
Full Well		41.39ke (HCG) 69.92ke (LCG)
SNRmax		46.17dB (HCG) 51.47dB (LCG)
Sensitivity		TBD
Dark current		TBD
Gain range		1x-15x
Exposure time		15μs-60sec
Shutter		Global shutter
Binning		Software 2×2, 3×3, 4×4
Data interface		CoaXPress 2.0 (CXP-10 x 1)
Digital I/O		One optical-coupling isolated input, one optical-coupling isolated output, two non-isolated input and output
Data Format		8bit / 12bit
Cooling performance		10°C below ambient temperature
Optical filter		400-1800nm(default); 1030-1800nm(optional)
CRA		2.35 Deg
General specification		
Power supply		Power over CoaXPress (PoCXP) / 12V Power Adapter
Power consumption		TBD
Temperature		Working temperature -20~60°C, storage temperature -40~85°C
Humidity		20%-80%, no condensation
Size		80mm×80mm×45.5mm
Weight		<390g
Lens mount		C-mount
Software		EHDview/ SDK
Operating system		Win32/WinRT/Linux/macOS/Android
Certification		CE, FCC

3.2.4 MaxCam-993TE-TR-CL150

Table 3-15 MaxCam-993TE-TR-CL150 camera specifications

Parameter	Model
	SWIR3000KMA-CL150 3.0Mpixels 1/1.8" CMOS Camera Link industrial camera
Camera Parameters	
Sensor model	Sony IMX993-AABA-C
Sensor Type	InGaAs
Spectral Range	400nm-1700nm
Pixel size	3.45 μm x 3.45 μm
Sensor size	1/1.8"
ADC	12 Bit / 10 Bit
Frame rate	10 Bit: 124fps@2048×1536 / 176fps@1024×768 12 Bit: 100fps@2048×1536 / 176fps@1024×768
Image Buffer	512MByte
Conversion Gain	10.3e/ADU (HCG) 17.29e/ADU (LCG)
Dynamic range	51.36dB (HCG) 51.47dB (LCG)
Readout Noise	111.88e (HCG) 186.61e (LCG)
Full Well	41.39ke (HCG) 69.92ke (LCG)
SNRmax	46.17dB (HCG) 48.45dB (LCG)
Sensitivity	TBD
Dark current	TBD
Gain range	1x-15x
Exposure time	15 μs -60sec
Shutter	Global shutter
Binning	Software 2×2, 3×3, 4×4
Data interface	GigE
Digital I/O	One optical-coupling isolated input, one optical-coupling isolated output, two non-isolated input and output
Data Format	8bit / 12bit
Cooling performance	10°C below ambient temperature
Optical filter	400-1800nm(default); 1030-1800nm(optional)
CRA	2.35 Deg
General specification	
Power supply	12V Power adapter
Power consumption	TBD
Temperature	Working temperature -20~60°C, storage temperature -40~85°C
Humidity	20%-80%, no condensation
Size	75mm×75mm×81.9mm
Weight	<390g
Lens mount	C-mount
Software	EHDview/ SDK
Operating system	Win32/WinRT/Linux/macOS/Android
Certification	CE, FCC

IMX992-AABA(TS) vs IMX990-AABA(MP)

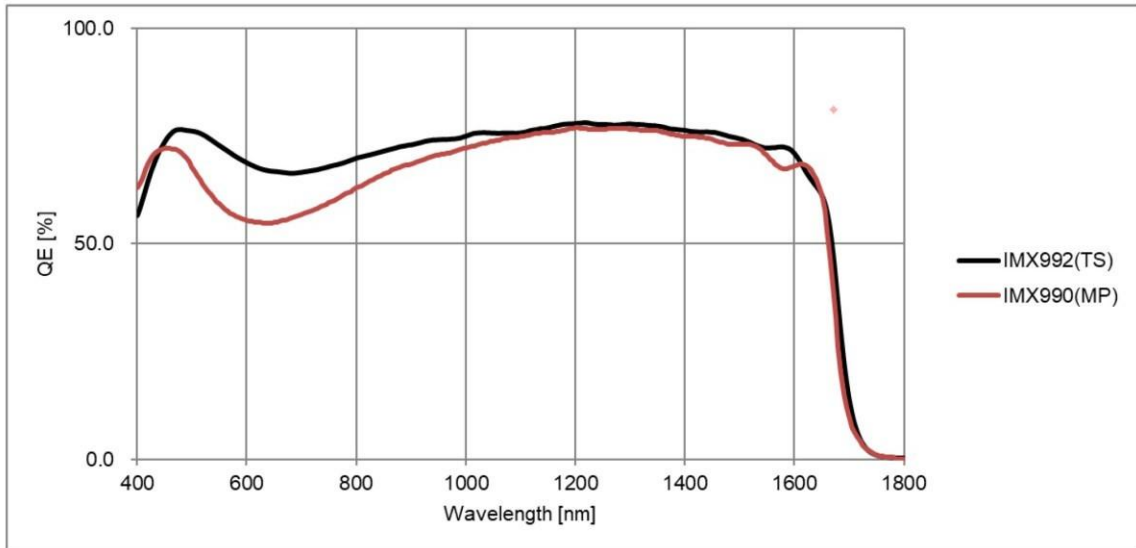

***NOTE**

- The data for B were measured at TS. It is possible to change at ES/MP.
- This data is reference for understanding of IMX992-AABA Quantum Efficiency characteristics. It is NOT guarantee of IMX992-AABA characteristics.
- Data acquisition conditions.
 - $T_j = 15^\circ\text{C}$
 - Characteristics in the package status
 - Constant photon number at each wavelength

Figure 3-2 MaxCam-992TE-TR-G, MaxCam-992-TR-G absolute quantum efficiency

3.2.5 MaxCam-993-TR

Table 3-16 MaxCam-993-TR camera specifications

Parameter	Model
	SWIR3000KMB
3.0M pixels 1/1.8" CMOS USB3 industrial camera	
Camera Parameters	
Sensor model	Sony IMX993-AABJ-C
Sensor Type	InGaAs
Spectral Range	400nm-1700nm
Pixel size	3.45 μm x 3.45 μm
Sensor size	1/1.8"
ADC	12 Bit / 8 Bit
Frame rate	8 Bit:93fps@2048×1536 / 176fps@1024×768 12 Bit:57fps@2048×1536 / 176fps@1024×768
Image Buffer	512MByte
Conversion Gain	10.3e/ADU (HCG) 17.29e/ADU (LCG)
Dynamic range	51.36dB (HCG) 51.47dB (LCG)
Readout Noise	111.88e (HCG) 186.61e (LCG)
Full Well	41.39ke (HCG) 69.92ke (LCG)
SNRmax	46.17dB (HCG) 48.45dB (LCG)
Sensitivity	TBD
Dark current	TBD
Gain range	1x-15x
Exposure time	15 μs -60sec
Shutter	Global shutter
Binning	Software 2×2, 3×3, 4×4
Data interface	USB3
Digital I/O	One optical-coupling isolated input, one optical-coupling isolated output, two non-isolated input and output
Data Format	8bit / 12bit
Cooling performance	10°C below ambient temperature
Optical filter	400-1800nm(default); 1030-1800nm(optional)
CRA	2.35 Deg
General specification	
Power supply	Power with USB3.0 or 12V Power adapter
Power consumption	<2.1W(without cooling) / <25W(cooling)
Temperature	Working temperature -20~60°C, storage temperature -40~85°C
Humidity	20%-80%, no condensation
Size	80mm×80mm×45.5mm
Weight	<390g
Lens mount	C-mount
Software	EHDview/ SDK
Operating system	Win32/WinRT/Linux/macOS/Android
Certification	CE, FCC

3.2.6 SC993-TR-UMV

Table 3-17 SC993-TR-UMV camera specifications

Parameter	Model
	SWIR3000KMB-UMV 3.0M pixels 1/1.8" CMOS USB3 industrial camera
Camera Parameters	
Sensor model	Sony IMX993-AABJ-C
Sensor Type	InGaAs
Spectral Range	400nm-1700nm
Pixel size	3.45 μm x 3.45 μm
Sensor size	1/1.8"
ADC	12 Bit / 8 Bit
Frame rate	8 Bit:93fps@2048×1536 / 176fps@1024×768 12 Bit:57fps@2048×1536 / 176fps@1024×768
Image Buffer	512MByte
Conversion Gain	10.3e/ADU (HCG) 17.29e/ADU (LCG)
Dynamic range	51.36dB (HCG) 51.47dB (LCG)
Readout Noise	111.88e (HCG) 186.61e (LCG)
Full Well	41.39ke (HCG) 69.92ke (LCG)
SNRmax	46.17dB (HCG) 48.45dB (LCG)
Sensitivity	TBD
Dark current	TBD
Gain range	1x-15x
Exposure time	15μs-60sec
Shutter	Global shutter
Binning	Software 2×2, 3×3, 4×4
Data interface	USB3
Digital I/O	One optical-coupling isolated input, one optical-coupling isolated output, one non-isolated input and output
Data Format	8bit / 12bit
Optical filter	400-1800nm(default); 1030-1800nm(optional)
CRA	2.35 Deg
General specification	
Power supply	Power with USB3.0
Power consumption	<2.11W
Temperature	Working temperature -20~60°C, storage temperature -40~85°C
Humidity	20%-80%, no condensation
Size	33mm×33mm×38mm
Weight	70g
Lens mount	C-mount
Software	EHDview/ SDK
Operating system	Win32/WinRT/Linux/macOS/Android
Certification	CE, FCC

3.2.7 SC993-TR-GMV

Table 3-18 SC993-TR-GMV camera specifications

Parameter	Model
	SWIR3000KMB-GMV 3.0Mpixels/1.8" CMOS GigE industrial camera
Camera Parameters	
Sensor model	Sony IMX993-AABJ-C
Sensor Type	InGaAs
Spectral Range	400nm-1700nm
Pixel size	3.45 μm x 3.45 μm
Sensor size	1/1.8"
ADC	12 Bit / 8 Bit
Frame rate	8 Bit:37fps@2048×1536 / 148fps@1024×768 12 Bit:18.5fps@2048×1536 / 74fps@1024×768
Image Buffer	512MByte
Conversion Gain	10.3e/ADU (HCG) 17.29e/ADU (LCG)
Dynamic range	51.36dB (HCG) 51.47dB (LCG)
Readout Noise	111.88e (HCG) 186.61e (LCG)
Full Well	41.39ke (HCG) 69.92ke (LCG)
SNRmax	46.17dB (HCG) 48.45dB (LCG)
Sensitivity	TBD
Dark current	TBD
Gain range	1x-15x
Exposure time	15 μs -60sec
Shutter	Global shutter
Binning	Software2×2, 3×3, 4×4
Data interface	GigE
Digital I/O	One optical-coupling isolated input, one optical-coupling isolated output, two non-isolated input and output
Data Format	8bit / 12bit
Optical filter	400-1800nm(default); 1030-1800nm(optional)
CRA	2.35 Deg
General specification	
Power supply	12V Power adapter
Power consumption	<2.11W
Temperature	Working temperature -20~60°C, storage temperature -40~85°C
Humidity	20%-80%, no condensation
Size	33mm×33mm×58mm
Weight	TBD
Lens mount	C-mount
Software	EHDview/ SDK
Operating system	Win32/WinRT/Linux/macOS/Android
Certification	CE, FCC

3.2.8 IMX993 QE Curve

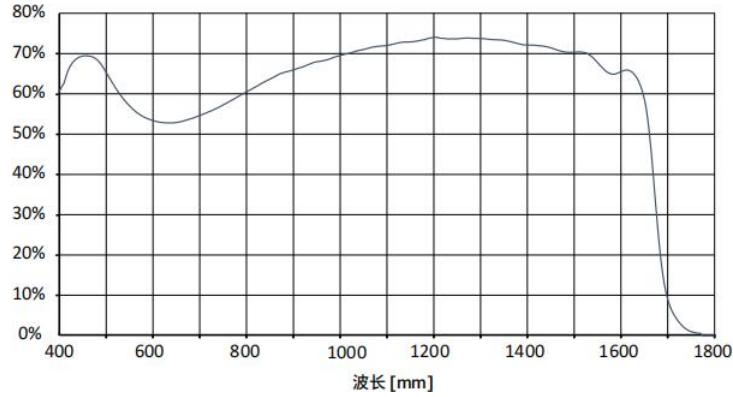

Figure 3-3 IM993 absolute quantum efficiency

3.2.9 IMX993 Camera performance parameters

The performance parameters of the camera are as follows:

- Maximum Resolution
- RAW 12 Bit mode
- Temperature: 5°C
- HCG

Table 3-19 MaxCam-993TE-TR Camera performance parameters

Gain Value	100	141	199	282	398	562	794	1500
e-/ADU	10.30	7.10	4.90	3.40	2.38	1.65	1.18	0.66
Read Noise (e-)	111.88	106.44	103.46	100.22	98.45	95.73	95.01	100.87
Full Well (ke-)	41.39	28.46	19.56	13.46	9.35	6.424	4.50	2.38
DR (dB)	51.3	48.5	45.5	42.5	39.5	36.5	33.5	27.4

Table 3-20 MaxCam-993-TR Camera performance parameters

Gain Value	100	141	199	282	398	562	794	1500
e-/ADU	10.48	7.13	4.92	3.38	2.34	1.64	1.11	0.33
Read Noise (e-)	123.05	116.96	114.17	110.19	105.91	102.38	94.43	49.93
Full Well (ke-)	41.80	28.44	19.56	13.44	9.28	6.46	4.37	1.27
DR (stop)	50.6	47.7	44.7	41.7	38.8	36.0	33.3	28.1

3.3 SWIR 400-1700 1.3MP 5um IMX990(8)

3.3.1 MaxCam-990TE-TR

Table 3-21 MaxCam-990TE-TR camera specifications

Parameter	Model
	SWIR1300KMA 1.31M pixels 1/2" CMOS USB3 industrial camera
Camera Parameters	
Sensor model	Sony IMX990-AABA-C
Sensor Type	InGaAs
Spectral Range	400nm-1700nm
Pixel size	5.0 μm x 5.0 μm
Sensor size	1/2"
ADC	12 Bit / 8 Bit
Frame rate	8 Bit:200fps@1280 × 1024 / 392fps@640 × 512 12 Bit:108fps@1280 × 1024 / 209fps@640 × 512
Image Buffer	512MByte
Conversion Gain	44.3e/ADU
Dynamic range	58.7dB
Readout Noise	211e
Full Well	181.6ke
SNRmax	52.6dB
Sensitivity	121mV
Dark current	383e/s(0°C) 510e/s(10°C) 638e/s(20°C)
Gain range	1x-15x
Exposure time	15μs-60sec
Shutter	Global shutter
Binning	Software 2×2, 3×3, 4×4
Data interface	USB3
Digital I/O	One optical-coupling isolated input, one optical-coupling isolated output, two non-isolated input and output
Data Format	8bit / 12bit
Cooling performance	25°C below ambient temperature
Optical filter	400-1800nm(default); 1030-1800nm(optional)
CRA	2.35 Deg
General specification	
Power supply	Power with USB3.0 or 12V Power adapter
Power consumption	<2.1W(without cooling) / <25W(cooling)
Temperature	Working temperature -20~60°C, storage temperature -40~85°C
Humidity	20%-80%, no condensation
Size	80mm×80mm×45.5mm
Weight	<390g
Lens mount	C-mount
Software	EHDview/ SDK
Operating system	Win32/WinRT/Linux/macOS/Android
Certification	CE, FCC

3.3.2 MaxCam-990TE-TR-G

Table 3-22 MaxCam-990TE-TR-G camera specifications

Parameter	Model
	SWIR1300KMA-G 1.31M pixels 1/2" CMOS GigE industrial camera
Camera Parameters	
Sensor model	Sony IMX990-AABA-C
Sensor Type	InGaAs
Spectral Range	400nm-1700nm
Pixel size	5.0 μm x 5.0 μm
Sensor size	1/2"
ADC	12 Bit / 8 Bit
Frame rate	8 Bit:90fps@1280 × 1024 / 253fps@640 × 512 12 Bit:45fps@1280 × 1024 / 135fps@640 × 512
Image Buffer	512MByte
Conversion Gain	44.3e/ADU
Dynamic range	58.7dB
Readout Noise	211e
Full Well	181.6ke
SNRmax	52.6dB
Sensitivity	121mV
Dark current	383e/s(0°C) 510e/s(10°C) 638e/s(20°C)
Gain range	1x-15x
Exposure time	15 μs -60sec
Shutter	Global shutter
Binning	Software 2×2, 3×3, 4×4
Data interface	GigE
Digital I/O	One optical-coupling isolated input, one optical-coupling isolated output, two non-isolated input and output
Data Format	8bit / 12bit
Cooling performance	25°C below ambient temperature
Optical filter	400-1800nm(default); 1030-1800nm(optional)
CRA	2.35 Deg
General specification	
Power supply	12V Power adapter
Power consumption	<2.1W(without cooling) / <25W(cooling)
Temperature	Working temperature -20~60°C, storage temperature -40~85°C
Humidity	20%-80%, no condensation
Size	80mm×80mm×45.5mm
Weight	<390g
Lens mount	C-mount
Software	EHDview/ SDK
Operating system	Win32/WinRT/Linux/macOS/Android
Certification	CE, FCC

3.3.3 MaxCam-990TE-TR-CXP

Table 3-23 MaxCam-990TE-TR-CXP camera specifications

Parameter	Model
Camera Parameters	
Sensor model	Sony IMX990-AABA-C
Sensor Type	InGaAs
Spectral Range	400nm-1700nm
Pixel size	5.0 μm x 5.0 μm
Sensor size	1/2"
ADC	12 Bit / 8 Bit
Frame rate	8 Bit:134fps@1280×1024 / 260fps@640×512 10 Bit:125fps@1280×1024 / 242fps@640×512 12 Bit:71fps@1280×1024 / 138fps@640×512
Image Buffer	512MByte
Conversion Gain	44.3e/ADU
Dynamic range	58.7dB
Readout Noise	211e
Full Well	181.6ke
SNRmax	52.6dB
Sensitivity	121mV
Dark current	383e/s(0°C) 510e/s(10°C) 638e/s(20°C)
Gain range	1x-15x
Exposure time	15 μs -60sec
Shutter	Global shutter
Binning	Software 2×2, 3×3, 4×4
Data interface	CoaXPress 2.0 (CXP-10 x 1)
Digital I/O	One optical-coupling isolated input, one optical-coupling isolated output, two non-isolated input and output
Data Format	8bit / 12bit
Cooling performance	25°C below ambient temperature
Optical filter	400-1800nm(default); 1030-1800nm(optional)
CRA	2.35 Deg
General specification	
Power supply	Power over CoaXPress (PoCXP) / 12V Power Adapter
Power consumption	<2.1W(without cooling) / <25W(cooling)
Temperature	Working temperature -20~60°C, storage temperature -40~85°C
Humidity	20%-80%, no condensation
Size	80mm×80mm×45.5mm
Weight	<390g
Lens mount	C-mount
Software	EHDview/ SDK
Operating system	Win32/WinRT/Linux/macOS/Android
Certification	CE, FCC

3.3.4 MaxCam-990TE-TR-CL180

Table 3-24 MaxCam-990TE-TR-CL180 camera specifications

Parameter	Model
	SWIR1300KMA-CL180 1.31Mpixels 1/2" CMOS CameraLink industrial camera
Camera Parameters	
Sensor model	Sony IMX990-AABA-C
Sensor Type	InGaAs
Spectral Range	400nm-1700nm
Pixel size	5.0 μm x 5.0 μm
Sensor size	1/2"
ADC	12 Bit / 8 Bit
Frame rate	8 Bit:183fps@1280 × 1024 / 350fps@640 × 512 12 Bit:97fps@1280 × 1024 / 185fps@640 × 512
Image Buffer	512MByte
Conversion Gain	44.3e/ADU
Dynamic range	58.7dB
Readout Noise	211e
Full Well	181.6ke
SNRmax	52.6dB
Sensitivity	121mV
Dark current	383e/s(0°C) 510e/s(10°C) 638e/s(20°C)
Gain range	1x-15x
Exposure time	15μs-60sec
Shutter	Global shutter
Binning	Nonsupport
Data interface	CameraLink
Digital I/O	One optical-coupling isolated input, one optical-coupling isolated output, two non-isolated input and output
Data Format	8bit / 12bit
Cooling performance	25°C below ambient temperature
Optical filter	400-1800nm(default); 1030-1800nm(optional)
CRA	2.35 Deg
General specification	
Power supply	12V Power adapter
Power consumption	<2.1W(without cooling) / <25W(cooling)
Temperature	Working temperature -20~60°C, storage temperature -40~85°C
Humidity	20%-80%, no condensation
Size	80mm×80mm×45.5mm
Weight	<390g
Lens mount	C-mount
Software	EHDview/ SDK
Operating system	Win32/WinRT/Linux/macOS/Android
Certification	CE, FCC

3.3.5 MaxCam-990-TR

Table 3-25 MaxCam-990-TR camera specifications

Parameter	Model
	SWIR1300KMB 1.3M pixels 1/2" CMOS USB3 industrial camera
Camera Parameters	
Sensor model	Sony IMX990-AABJ-C
Sensor Type	InGaAs
Spectral Range	400nm-1700nm
Pixel size	5.0 μm x 5.0 μm
Sensor size	1/2"
ADC	12 Bit / 8 Bit
Frame rate	8 Bit:200fps@1280 × 1024 / 392fps@640 × 512 12 Bit:108fps@1280 × 1024 / 209fps@640 × 512
Image Buffer	512MByte
Conversion Gain	42.8e/ADU
Dynamic range	58.7dB
Readout Noise	197.6e
Full Well	175.4ke
SNRmax	52.4dB
Sensitivity	121mV
Dark current	638e/s(20°C)
Gain range	1x-15x
Exposure time	15μs-60sec
Shutter	Global shutter
Binning	Software2×2, 3×3, 4×4
Data interface	USB3
Digital I/O	One optical-coupling isolated input, one optical-coupling isolated output, two non-isolated input and output
Data Format	8bit / 12bit
Cooling performance	10°C below ambient temperature
Optical filter	400-1800nm(default); 1030-1800nm(optional)
CRA	2.35 Deg
General specification	
Power supply	Power with USB3.0 or 12V Power adapter
Power consumption	<2.1W(without cooling) / <25W(cooling)
Temperature	Working temperature -20~60°C, storage temperature -40~85°C
Humidity	20%-80%, no condensation
Size	80mm×80mm×45.5mm
Weight	<390g
Lens mount	C-mount
Software	EHDview/ SDK
Operating system	Win32/WinRT/Linux/macOS/Android
Certification	CE, FCC

3.3.6 MaxCam-990-TR-G

Table 3-26 MaxCam-990-TR-G camera specifications

Parameter	Model
	SWIR1300KMB-G 1.3Mpixels 1/2" CMOS GigE industrial camera
Camera Parameters	
Sensor model	Sony IMX990-AABJ-C
Sensor Type	InGaAs
Spectral Range	400nm-1700nm
Pixel size	5.0 μm x 5.0 μm
Sensor size	1/2"
ADC	12 Bit / 8 Bit
Frame rate	8 Bit:90fps@1280 × 1024 / 253fps@640 × 512 12 Bit:45fps@1280 × 1024 / 135fps@640 × 512
Image Buffer	512MByte
Conversion Gain	42.8e/ADU
Dynamic range	58.7dB
Readout Noise	197.6e
Full Well	175.4ke
SNRmax	52.4dB
Sensitivity	121mV
Dark current	638e/s(20°C)
Gain range	1x-15x
Exposure time	15μs-60sec
Shutter	Global shutter
Binning	Software 2×2, 3×3, 4×4
Data interface	GigE
Digital I/O	One optical-coupling isolated input, one optical-coupling isolated output, two non-isolated input and output
Data Format	8bit / 12bit
Cooling performance	10°C below ambient temperature
Optical filter	400-1800nm(default); 1030-1800nm(optional)
CRA	2.35 Deg
General specification	
Power supply	12V Power adapter
Power consumption	<2.1W(without cooling) / <25W(cooling)
Temperature	Working temperature -20~60°C, storage temperature -40~85°C
Humidity	20%-80%, no condensation
Size	80mm×80mm×45.5mm
Weight	<390g
Lens mount	C-mount
Software	EHDview/ SDK
Operating system	Win32/WinRT/Linux/macOS/Android
Certification	CE, FCC

3.3.7 SC990-TR-UMV

Table 3-27 SC990-TR-UMV camera specifications

Parameter	Model
	SWIR1300KMB-UMV 1.3M pixels 1/2" CMOS USB3 industrial camera
Camera Parameters	
Sensor model	Sony IMX990-AABJ-C
Sensor Type	InGaAs
Spectral Range	400nm-1700nm
Pixel size	5.0 μm x 5.0 μm
Sensor size	1/2"
ADC	12 Bit / 8 Bit
Frame rate	8 Bit:223fps@1280 × 1024 / 428fps@640 × 512 12 Bit:118.7fps@1280 × 1024 / 227.7fps@640 × 512
Image Buffer	512MByte
Conversion Gain	42.8e/ADU
Dynamic range	58.7dB
Readout Noise	197.6e
Full Well	175.4ke
SNRmax	52.4dB
Sensitivity	121mV
Dark current	638e/s(20°C)
Gain range	1x-15x
Exposure time	15μs-60sec
Shutter	Global shutter
Binning	Software2×2, 3×3, 4×4
Data interface	USB3
Digital I/O	One optical-coupling isolated input, one optical-coupling isolated output, one non-isolated input and output
Data Format	8bit / 12bit
Cooling performance	10°C below ambient temperature
Optical filter	400-1800nm(default); 1030-1800nm(optional)
CRA	2.35 Deg
General specification	
Power supply	Power with USB3.0
Power consumption	<2.11W
Temperature	Working temperature -20~60°C, storage temperature -40~85°C
Humidity	20%-80%, no condensation
Size	33mm×33mm×38mm
Weight	70g
Lens mount	C-mount
Software	EHDview/ SDK
Operating system	Win32/WinRT/Linux/macOS/Android
Certification	CE, FCC

When the ambient temperature is 25.5 degrees, the camera is placed on a wooden table, and the exposure time is 1.5ms in 8bit mode.

Resolution	Overclock	Frame rate	Power consumption	Sensor temperature
1280*1024	Off	135fps	1.75W	42.3
1280*1024	On	223fps	2.11W	43.2
640*512	Off	258fps	1.51W	38.1
640*512	On	428fps	1.75W	40

3.3.8 SC990-TR-GMV

Table 3-28 SC990-TR-GMV camera specifications

Parameter	Model
	SWIR1300KMB-GMV 1.3M pixels 1/2" CMOS GigE industrial camera
Camera Parameters	
Sensor model	Sony IMX990-AABJ-C
Sensor Type	InGaAs
Spectral Range	400nm-1700nm
Pixel size	5.0 μm x 5.0 μm
Sensor size	1/2"
ADC	12 Bit / 8 Bit
Frame rate	8 Bit:90fps@1280 × 1024 / 253fps@640 × 512 12 Bit:45fps@1280 × 1024 / 135fps@640 × 512
Image Buffer	512MByte
Conversion Gain	42.8e/ADU
Dynamic range	58.7dB
Readout Noise	197.6e
Full Well	175.4ke
SNRmax	52.4dB
Sensitivity	121mV
Dark current	638e/s(20°C)
Gain range	1x-15x
Exposure time	15μs-60sec
Shutter	Global shutter
Binning	Software2×2, 3×3, 4×4
Data interface	GigE
Digital I/O	One optical-coupling isolated input, one optical-coupling isolated output, two non-isolated input and output
Data Format	8bit / 12bit
Cooling performance	10°C below ambient temperature
Optical filter	400-1800nm(default); 1030-1800nm(optional)
CRA	2.35 Deg
General specification	
Power supply	12V Power adapter
Power consumption	<2.11W
Temperature	Working temperature -20~60°C, storage temperature -40~85°C
Humidity	20%-80%, no condensation
Size	33mm×33mm×58mm
Weight	TBD
Lens mount	C-mount
Software	EHDview/ SDK
Operating system	Win32/WinRT/Linux/macOS/Android
Certification	CE, FCC

3.3.9 IMX990 QE Curve

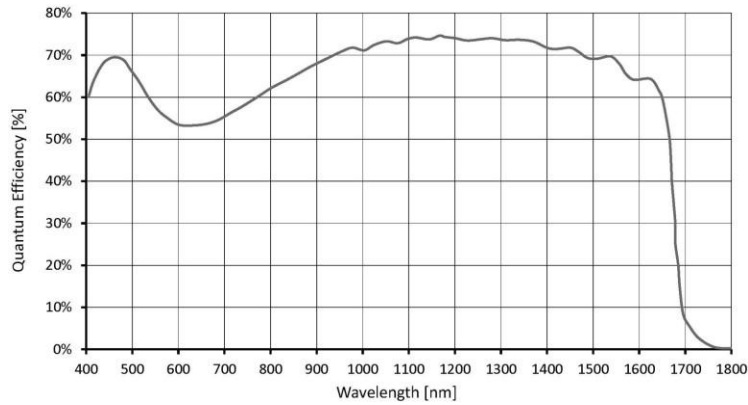

Figure 3-4 IM990 absolute quantum efficiency

3.3.10 IMX990 Camera performance parameters

The performance parameters of the camera are as follows:

- Maximum Resolution
- RAW 12 Bit mode
- Temperature: 5°C
- HCG

Table 3-29 MaxCam-990TE-TR Camera performance parameters

Gain Value	100	125	158	199	251	316	398	501	603	794	1000	1258	1500
Rel Gain (dB)	0.00	1.91	3.93	5.94	7.94	9.96	11.99	14.05	16.07	18.10	20.15	22.07	23.70
e-/ADU	44.32	35.56	28.21	22.37	17.76	14.08	11.15	8.79	6.97	5.52	4.36	3.49	2.90
Read Noise (e-)	210.89	209.29	209.71	208.16	207.64	205.12	203.76	202.01	199.78	197.93	198.65	198.47	198.65
Full Well (ke-)	181.55	145.64	115.53	91.64	72.76	57.68	45.68	36.02	28.55	22.60	17.85	14.30	11.86
DR (stop)	9.75	9.44	9.11	8.78	8.45	8.14	7.81	7.48	7.16	6.84	6.49	6.17	5.90

Table 3-30 MaxCam-990-TR Camera performance parameters

Gain Value	100	125	158	199	251	316	398	501	603	794	1000	1258	1500
Rel Gain (dB)	0.00	1.25	1.57	1.97	2.47	3.12	3.91	4.92	6.20	7.77	9.72	11.94	14.32
e-/ADU	42.82	34.37	27.32	21.75	17.31	13.73	10.95	8.71	6.91	5.51	4.40	3.59	2.99
Read Noise (e-)	197.63	196.91	195.76	198.17	195.23	195.78	195.14	196.15	193.04	195.82	203.27	208.32	208.36
Full Well (ke-)	175.41	140.77	111.90	89.07	70.90	56.25	44.84	35.67	28.30	22.57	18.04	14.69	12.25
DR (stop)	9.79	9.48	9.16	8.81	8.50	8.17	7.84	7.51	7.20	6.85	6.47	6.14	5.88

3.4 SWIR 400-1700 0.33MP 5um IMX991(8)

3.4.1 MaxCam-991TE-TR

Table 3-31 MaxCam-991TE-TR camera specifications

Parameter	Model
	SWIR330KMA 0.33Mpixels 1/4" CMOS USB3 industrial camera
Camera Parameters	
Sensor model	Sony IMX991-AABA-C
Sensor Type	InGaAs
Spectral Range	400nm-1700nm
Pixel size	5.0 μm x 5.0 μm
Sensor size	1/4"
ADC	12 Bit / 8 Bit
Frame rate	8 Bit:400fps@640 × 512 / 753fps@320 × 256 12 Bit:212fps@640 × 512 / 400fps@320 × 256
Image Buffer	512MByte
Conversion Gain	42.29e/ADU
Dynamic range	59.7dB
Readout Noise	176.7e
Full Well	173.23ke
SNRmax	52.39dB
Sensitivity	121mV
Dark current	383e/s(0°C) 510e/s(10°C) 638e/s(20°C)
Gain range	1x-15x
Exposure time	15μs-60sec
Shutter	Global shutter
Binning	Software 2×2, 3×3, 4×4
Data interface	USB3
Digital I/O	One optical-coupling isolated input, one optical-coupling isolated output, two non-isolated input and output
Data Format	8bit / 12bit
Cooling performance	25°C below ambient temperature
Optical filter	400-1800nm(default); 1030-1800nm(optional)
CRA	2.35 Deg
General specification	
Power supply	Power with USB3.0 or 12V Power adapter
Power consumption	<3W(without cooling) / <20W(cooling)
Temperature	Working temperature -20~60°C, storage temperature -40~85°C
Humidity	20%-80%, no condensation
Size	80mm×80mm×45.5mm
Weight	<390g
Lens mount	C-mount
Software	EHDview/ SDK
Operating system	Win32/WinRT/Linux/macOS/Android
Certification	CE, FCC

3.4.2 MaxCam-991TE-TR-G

Table 3-32 MaxCam-991TE-TR-G camera specifications

Parameter	Model
	SWIR330KMA-G 0.33M pixels 1/4" CMOS GigE industrial camera
Camera Parameters	
Sensor model	Sony IMX991-AABA-C
Sensor Type	InGaAs
Spectral Range	400nm-1700nm
Pixel size	5.0 μm x 5.0 μm
Sensor size	1/4"
ADC	12 Bit / 8 Bit
Frame rate	8 Bit:257.8fps@640 × 512 / 486.1fps@320 × 256 12 Bit:137.1fps@640 × 512 / 258.6fps@320 × 256
Image Buffer	512MByte
Conversion Gain	42.29e/ADU
Dynamic range	59.7dB
Readout Noise	176.7e
Full Well	173.23ke
SNRmax	52.39dB
Sensitivity	121mV
Dark current	383e/s(0°C) 510e/s(10°C) 638e/s(20°C)
Gain range	1x-15x
Exposure time	15μs-60sec
Shutter	Global shutter
Binning	Software 2×2, 3×3, 4×4
Data interface	GigE
Digital I/O	One optical-coupling isolated input, one optical-coupling isolated output, two non-isolated input and output
Data Format	8bit / 12bit
Cooling performance	25°C below ambient temperature
Optical filter	400-1800nm(default); 1030-1800nm(optional)
CRA	2.35 Deg
General specification	
Power supply	12V Power adapter
Power consumption	<2.1W(without cooling) / <25W(cooling)
Temperature	Working temperature -20~60°C, storage temperature -40~85°C
Humidity	20%-80%, no condensation
Size	80mm×80mm×45.5mm
Weight	<390g
Lens mount	C-mount
Software	EHDview/ SDK
Operating system	Win32/WinRT/Linux/macOS/Android
Certification	CE, FCC

3.4.3 MaxCam-991TE-TR-CXP

Table 3-33 MaxCam-991TE-TR-CXP camera specifications

Parameter	Model
Camera Parameters	
Sensor model	Sony IMX991-AABA-C
Sensor Type	InGaAs
Spectral Range	400nm-1700nm
Pixel size	5.0 μm x 5.0 μm
Sensor size	1/4"
ADC	12 Bit / 8 Bit
Frame rate	8 Bit:258fps@656×520 / 486fps@328×260 10 Bit:240fps@656×520 / 451fps@328×260 12 Bit:137fps@656×520 / 258fps@328×260
Image Buffer	512MByte
Conversion Gain	42.29e/ADU
Dynamic range	59.7dB
Readout Noise	176.7e
Full Well	173.23ke
SNRmax	52.39dB
Sensitivity	121mV
Dark current	383e/s(0°C) 510e/s(10°C) 638e/s(20°C)
Gain range	1x-15x
Exposure time	15μs-60sec
Shutter	Global shutter
Binning	Software 2×2, 3×3, 4×4
Data interface	CoaXPress 2.0 (CXP-10 x 1)
Digital I/O	One optical-coupling isolated input, one optical-coupling isolated output, two non-isolated input and output
Data Format	8bit / 12bit
Cooling performance	25°C below ambient temperature
Optical filter	400-1800nm(default); 1030-1800nm(optional)
CRA	2.35 Deg
General specification	
Power supply	Power over CoaXPress (PoCXP) / 12V Power Adapter
Power consumption	<2.1W(without cooling) / <25W(cooling)
Temperature	Working temperature -20~60°C, storage temperature -40~85°C
Humidity	20%-80%, no condensation
Size	80mm×80mm×45.5mm
Weight	<390g
Lens mount	C-mount
Software	EHDview/ SDK
Operating system	Win32/WinRT/Linux/macOS/Android
Certification	CE, FCC

3.4.4 MaxCam-991TE-TR-CL350

Table 3-34 MaxCam-991TE-TR-CL350 camera specifications

Parameter	Model	SWIR330KMA-CL350
		0.33Mpixels 1/4" CMOS CameraLink industrial camera
Camera Parameters		
Sensor model		Sony IMX991-AABA-C
Sensor Type		InGaAs
Spectral Range		400nm-1700nm
Pixel size		5.0 μm x 5.0 μm
Sensor size		1/4"
ADC		12 Bit / 8 Bit
Frame rate		8Bit:350fps@640×512 / 657fps@320×256 12bit:188fps@640×512 / 350fps@320×256
Image Buffer		512MByte
Conversion Gain		42.29e/ADU
Dynamic range		59.7dB
Readout Noise		176.7e
Full Well		173.23ke
SNRmax		52.39dB
Sensitivity		121mV
Dark current		383e/s(0°C) 510e/s(10°C) 638e/s(20°C)
Gain range		1x-15x
Exposure time		15μs-60sec
Shutter		Global shutter
Binning		Software 2×2, 3×3, 4×4
Data interface		Nonsupport
Digital I/O		One optical-coupling isolated input, one optical-coupling isolated output, two non-isolated input and output
Data Format		8bit / 12bit
Cooling performance		25°C below ambient temperature
Optical filter		400-1800nm(default); 1030-1800nm(optional)
CRA		2.35 Deg
General specification		
Power supply		12V Power adapter
Power consumption		<2.1W(without cooling) / <25W(cooling)
Temperature		Working temperature -20~60°C, storage temperature -40~85°C
Humidity		20%-80%, no condensation
Size		75mm×75mm×81.9mm
Weight		<390g
Lens mount		C-mount
Software		EHDview/ SDK
Operating system		Win32/WinRT/Linux/macOS/Android
Certification		CE, FCC

3.4.5 MaxCam-991-TR

Table 3-35 MaxCam-991-TR camera specifications

Parameter	Model
	SWIR330KMB
0.33M pixels 1/4" CMOS USB3 industrial camera	
Camera Parameters	
Sensor model	Sony IMX991-AABJ-C
Sensor Type	InGaAs
Spectral Range	400nm-1700nm
Pixel size	5.0 μm x 5.0 μm
Sensor size	1/4"
ADC	12 Bit / 8 Bit
Frame rate	8 Bit:400fps@640 × 512 / 753fps@320 × 256 12 Bit:212fps@640 × 512 / 400fps@320 × 256
Image Buffer	512MByte
Conversion Gain	43.0e/ADU
Dynamic range	59.6dB
Readout Noise	178.8e
Full Well	176.2ke
SNRmax	52.5dB
Sensitivity	121mV
Dark current	638e/s(20°C)
Gain range	1x-15x
Exposure time	15 μs -60sec
Shutter	Global shutter
Binning	Software2×2, 3×3, 4×4
Data interface	USB3
Digital I/O	One optical-coupling isolated input, one optical-coupling isolated output, two non-isolated input and output
Data Format	8bit / 12bit
Cooling performance	10°C below ambient temperature
Optical filter	400-1800nm(default); 1030-1800nm(optional)
CRA	2.35 Deg
General specification	
Power supply	Power with USB3.0 or 12V Power adapter
Power consumption	<2.1W(without cooling) / <25W(cooling)
Temperature	Working temperature -20~60°C, storage temperature -40~85°C
Humidity	20%-80%, no condensation
Size	80mm×80mm×45.5mm
Weight	<390g
Lens mount	C-mount
Software	EHDview/ SDK
Operating system	Win32/WinRT/Linux/macOS/Android
Certification	CE, FCC

3.4.6 SC-991-TR-WUH

Table 3-36 SC991-TR-WUH camera specifications

Parameter	Model	SWIR330KMB-WUH
0.33M pixels 1/4" CMOS HDMI/WiFi/USB industrial camera		
Camera Parameters		
Sensor model		Sony IMX991-AABJ-C
Sensor Type		InGaAs
Spectral Range		400nm-1700nm
Pixel size		5.0 μm x 5.0 μm
Sensor size		1/4"
ADC		12 Bit
Frame rate		HDMI: 60fps@1920 x 1080 (1080P) WiFi/USB: 137fps@640 x 512
Image Buffer		TBD
Conversion Gain		43.0e/ADU
Dynamic range		59.6dB
Readout Noise		178.8e
Full Well		176.2ke
SNRmax		52.5dB
Sensitivity		121mV
Dark current		638e/s(20°C)
Gain range		1x-50x
Exposure time		0.04ms-1000ms
Shutter		Global shutter
Binning		Software 2x2, 3x3, 4x4
Data interface		HDMI 1.4 / WiFi / USB Video (Micro USB)
Data Format		12bit
Cooling performance		Natural cooling
Optical filter		400-1800nm(default); 1030-1800nm(optional)
CRA		2.35 Deg
General specification		
Power supply		DC 12V/1A Power adapter
Power consumption		<3.2W
Temperature		Working temperature -10~50°C, storage temperature -20~60°C
Humidity		Operation: 30~80%RH; Storage: 10~60%RH
Size		50mm×50mm×71.5mm
Weight		TBD
Lens mount		C-mount
Software		Embedded XCamView / PC software EHDview & SDK
Operating system		Windows/macOS/Linux/Android/iOS
Certification		CE, FCC

3.4.7 MaxCam-991-TR-G

Table 3-37 MaxCam-991-TR-G camera specifications

Parameter	Model
	SWIR330KMB-G
0.33M pixels 1/4" CMOS GigE industrial camera	
Camera Parameters	
Sensor model	Sony IMX991-AABJ-C
Sensor Type	InGaAs
Spectral Range	400nm-1700nm
Pixel size	5.0 μm x 5.0 μm
Sensor size	1/4"
ADC	12 Bit / 8 Bit
Frame rate	8 Bit:257.8fps@640 \times 512 / 486.1fps@320 \times 256 12 Bit:137.1fps@640 \times 512 / 258.6fps@320 \times 256
Image Buffer	512MByte
Conversion Gain	43.0e/ADU
Dynamic range	59.6dB
Readout Noise	178.8e
Full Well	176.2ke
SNRmax	52.5dB
Sensitivity	121mV
Dark current	638e/s(20°C)
Gain range	1x-15x
Exposure time	15 μs -60sec
Shutter	Global shutter
Binning	Software2 \times 2, 3 \times 3, 4 \times 4
Data interface	GigE
Digital I/O	One optical-coupling isolated input, one optical-coupling isolated output, two non-isolated input and output
Data Format	8bit / 12bit
Cooling performance	10°C below ambient temperature
Optical filter	400-1800nm(default); 1030-1800nm(optional)
CRA	2.35 Deg
General specification	
Power supply	12V Power adapter
Power consumption	<2.1W(without cooling) / <25W(cooling)
Temperature	Working temperature -20~60°C, storage temperature -40~85°C
Humidity	20%-80%, no condensation
Size	80mm \times 80mm \times 45.5mm
Weight	<390g
Lens mount	C-mount
Software	EHDview/ SDK
Operating system	Win32/WinRT/Linux/macOS/Android
Certification	CE, FCC

3.4.8 SC991-TR-UMV

Table 3-38 SC991-TR-UMV camera specifications

Parameter	Model	SWIR330KMB-UMV 0.33M pixels 1/4" CMOS USB3 industrial camera
Camera Parameters		
Sensor model		Sony IMX991-AABJ-C
Sensor Type		InGaAs
Spectral Range		400nm-1700nm
Pixel size		5.0 μm x 5.0 μm
Sensor size		1/4"
ADC		12 Bit
Frame rate		137fps@640 * 512
Image Buffer		512MByte
Conversion Gain		43.0e/ADU
Dynamic range		59.6dB
Readout Noise		178.8e
Full Well		176.2ke
SNRmax		52.5dB
Sensitivity		121mV
Dark current		638e/s(20°C)
Gain range		1x-15x
Exposure time		15μs-60sec
Shutter		Global shutter
Binning		Software 2×2, 3×3, 4×4
Data interface		USB3.0
Data Format		12bit
Optical filter		400-1800nm(default); 1030-1800nm(optional)
CRA		2.35 Deg
General specification		
Power supply		Power with USB3.0
Power consumption		<2.11W
Temperature		Working temperature -20~60°C, storage temperature -40~85°C
Humidity		20%-80%, no condensation
Size		33mm×33mm×38mm
Weight		70g
Lens mount		C-mount
Software		EHDview/ SDK
Operating system		Win32/WinRT/Linux/macOS/Android
Certification		CE, FCC

3.4.9 SC991-TR-GMV

Table 3-39 SC991-TR-GMV camera specifications

Parameter	Model
	SWIR330KMB-GMV 0.33M pixels 1/4" CMOS GigE industrial camera
Camera Parameters	
Sensor model	Sony IMX991-AABJ-C
Sensor Type	InGaAs
Spectral Range	400nm-1700nm
Pixel size	5.0 μm x 5.0 μm
Sensor size	1/4"
ADC	12 Bit / 8 Bit
Frame rate	8 Bit:257.8fps@640 × 512 / 486.1fps@320 × 256 12 Bit:137.1fps@640 × 512 / 258.6fps@320 × 256
Image Buffer	512MByte
Conversion Gain	43.0e/ADU
Dynamic range	59.6dB
Readout Noise	178.8e
Full Well	176.2ke
SNRmax	52.5dB
Sensitivity	121mV
Dark current	638e/s(20°C)
Gain range	1x-15x
Exposure time	15μs-60sec
Shutter	Global shutter
Binning	Software2×2, 3×3, 4×4
Data interface	GigE
Digital I/O	One optical-coupling isolated input, one optical-coupling isolated output, two non-isolated input and output
Data Format	8bit / 12bit
Optical filter	400-1800nm(default); 1030-1800nm(optional)
CRA	2.35 Deg
General specification	
Power supply	12V Power adapter
Power consumption	<2.11W
Temperature	Working temperature -20~60°C, storage temperature -40~85°C
Humidity	20%-80%, no condensation
Size	33mm×33mm×58mm
Weight	TBD
Lens mount	C-mount
Software	EHDview/ SDK
Operating system	Win32/WinRT/Linux/macOS/Android
Certification	CE, FCC

3.4.10 IMX991 QE Curve

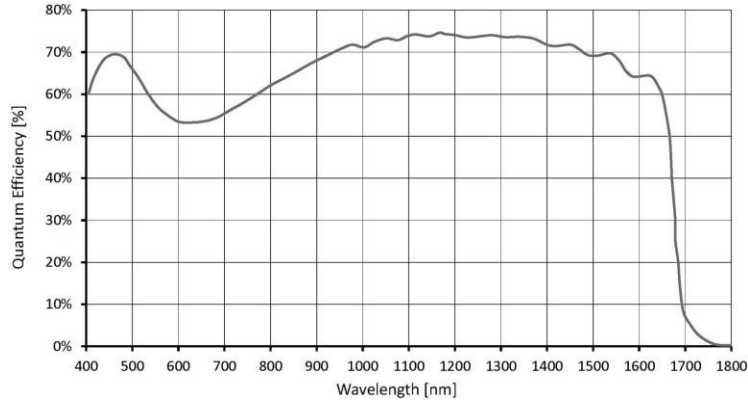

Figure 3-5 IM991 absolute quantum efficiency

3.4.11 IMX991 Camera performance parameters

The performance parameters of the camera are as follows:

- Maximum Resolution
- RAW 12 Bit mode
- Temperature: 5°C
- HCG

Table 3-40 MaxCam-991TE-TR Camera performance parameters

Gain Value	100	125	158	199	251	316	398	501	603	794	1000	1258	1500
Rel Gain (dB)	0.00	1.89	3.91	5.88	7.88	9.89	11.88	13.87	15.85	17.84	19.82	21.66	23.23
e-/ADU	42.29	34.00	26.98	21.48	17.07	13.54	10.77	8.57	6.82	5.43	4.32	3.49	2.92
Read Noise (e-)	174.99	169.28	172.01	171.45	170.73	169.36	168.80	170.65	173.33	176.87	184.04	189.99	187.34
Full Well (ke-)	173.23	139.27	110.49	87.99	69.90	55.47	44.11	35.08	27.92	22.23	17.69	14.31	11.95
DR (stop)	9.95	9.68	9.33	9.00	8.68	8.36	8.03	7.68	7.33	6.97	6.59	6.24	6.00

Table 3-41 MaxCam-991-TR Camera performance parameters

Gain Value	100	125	158	199	251	316	398	501	603	794	1000	1258	1500
Rel Gain (dB)	0.00	1.90	3.90	5.91	7.91	9.93	11.92	13.93	15.92	17.90	19.94	21.70	23.21
e-/ADU	43.01	34.57	27.45	21.79	17.30	13.72	10.91	8.65	6.88	5.48	4.33	3.54	2.97
Read Noise (e-)	178.78	178.53	179.35	178.94	178.17	174.61	174.78	172.38	176.29	181.30	186.37	196.79	197.80
Full Well (ke-)	176.17	141.60	112.42	89.26	70.86	56.18	44.67	35.44	28.18	22.43	17.74	14.49	12.18
DR (stop)	9.94	9.63	9.29	8.96	8.64	8.33	8.00	7.68	7.32	6.95	6.57	6.20	5.94

4 SWIR 900-1700 camera model specifications

4.1 SWIR 900-1700 1.3MP 15um(6)

4.1.1 EHD1302KMB-CXP

Table 4-1 EHD1302KMB-CXP camera specifications

Parameter	Model
	SWIR1302KMB-CXP 1.3M pixels 1.5" InGaAs CoaXPresscamera
Camera Parameters	
Sensor model	InGaAs sensor 1280x1024
Sensor Type	InGaAs CMOS image sensor
Spectral Range	900 nm - 1700 nm
Pixel size	15 μm x 15 μm
Sensor size	1.5"
ADC	14-bit
Frame rate	100 fps @ 1280 x 1024
Image Buffer	512 MByte
QE	≥ 70 @ 1.55 μm
Conversion Gain	1 $\mu\text{V}/\text{e}^-$ (LG), 16 $\mu\text{V}/\text{e}^-$ (MG), 53.3 $\mu\text{V}/\text{e}^-$ (HG)
Dynamic range	69.2 dB (LG), 63.2 dB (MG), 57.4 dB (HG) *1 (for reference only)
Readout Noise	1.3 DN (LG), 2.7 DN (MG), 5.0 DN (HG) (for reference only)
Full Well	1.9 Me $^-$ (LG), 118.75 ke $^-$ (MG), 33.75 ke $^-$ (HG) *1
SNRmax	65.4 dB (LG), 48.5 dB (MG), 40.7 dB (HG) (for reference only)
Dark current	30 fA @ 0.1 V, 18 $^{\circ}\text{C}$ (for reference only)
Exposure time	16 μs - 5 s
Shutter	Global shutter
Data interface	CoaXPress 2.0 (CXP-10 x 1)
Digital I/O	One optical-coupling isolated input, one optical-coupling isolated output, two non-isolated input/output ports
Data Format	Mono 8 / Mono 14
Cooling performance	40 $^{\circ}\text{C}$ below ambient temperature
General specification	
Power supply	Power over CoaXPress (PoCXP) / 12V Power Adapter
Power consumption	6.1W (TEC OFF) / 18.8W(TEC ON)
Temperature	Operating temperature -30~60 $^{\circ}\text{C}$, storage temperature -40~85 $^{\circ}\text{C}$
Humidity	20%-80%, no condensation
Size	68mm \times 68mm \times 95.8mm
Weight	528.7 g
Lens mount	M42 mount
Software	Complete SDK / EHDview

*1: LG: CDS-OFF, DeNoise-ON; MG: CDS-ON, DeNoise-OFF; HG: CDS-ON, DeNoise-OFF.

4.1.2 EHD303KMB-G

Table 4-2 EHD1303KMB-G camera specifications

Parameter	Model	SWIR1303KMB-G 1.3Mpixels 1.5" InGaAs GigE camera
Camera Parameters		
Sensor model		InGaAs sensor 1280 × 1024
Sensor Type		InGaAs
Spectral Range		900 nm – 1700 nm
Pixel size		15 μm × 15 μm
Sensor size		1.5"
ADC		14-bit
Frame rate		100 fps @ 1280 × 1024
Image Buffer		512 MByte
Conversion Gain		87fps@1280 x 1024
Dynamic range		512MByte
Readout Noise		130.258e ⁻ /ADU (LG), 6.085e ⁻ /ADU (MG), 1.459e ⁻ /ADU (HG)
Full Well		71.5dB (LG), 65.7dB (MG), 54.4dB (HG)
SNRmax		562.92e ⁻ (LG), 51.63e ⁻ (MG), 45.63e ⁻ (HG)
Dark current		< 30 fA @ 0.5 V, 20 °C (for reference only; subject to actual conditions)
Exposure time		16 μs – 5 s
Shutter		Global shutter
Binning		Software 2 × 2, 3 × 3, 4 × 4
Data interface		GigE
Digital I/O		One optical-coupling isolated input, one optical-coupling isolated output, two non-isolated input/output
Data Format		Mono 8 / Mono 14
Cooling performance		40 °C below ambient temperature
General specification		
Power supply		DC 12 V
Power consumption		TBD
Temperature		Operating temperature –20 to 60 °C, storage temperature –40 to 85 °C
Humidity		20%–80%, no condensation
Size		68 mm × 68 mm × 90 mm
Weight		TBD
Lens mount		M42 mount
Software		EHDview / SDK

*1: LG: CDS-OFF, DeNoise-ON; MG: CDS-ON, DeNoise-OFF; HG: CDS-ON, DeNoise-OFF.

4.1.3 EHD1303KMB-10G

Table 4-3 EHD1303KMB-10G camera specifications

Parameter	Model	SWIR1303KMB-10G 1.3Mpixels1.5" InGaAs 10GigE camera
Camera Parameters		
Sensor model		InGaAs sensor 1280 × 1024
Sensor Type		InGaAs
Spectral Range		900 nm – 1700 nm
Pixel size		15 μm × 15 μm
Sensor size		1.5"
ADC		14-bit
Frame rate		100 fps @ 1280 × 1024
Image Buffer		512 MByte
Conversion Gain		130.258 e ⁻ /ADU (LG), 6.085 e ⁻ /ADU (MG), 1.459 e ⁻ /ADU (HG)
Dynamic range		71.5 dB (LG), 65.7 dB (MG), 54.4 dB (HG)
Readout Noise		562.92 e ⁻ (LG), 51.63 e ⁻ (MG), 45.63 e ⁻ (HG)
Full Well		2.13 Me ⁻ (LG), 99.546 ke ⁻ (MG), 23.845 ke ⁻ (HG)
SNRmax		63.1 dB (LG), 50.0 dB (MG), 43.8 dB (HG)
Dark current		< 30 fA @ 0.5 V, 20 °C (for reference only; subject to actual conditions)
Exposure time		16 μs – 5 s
Shutter		Global shutter
Binning		Software 2 × 2, 3 × 3, 4 × 4
Data interface		10G
Digital I/O		One optical-coupling isolated input, one optical-coupling isolated output, two non-isolated input/output
Data Format		Mono 8 / Mono 14
Cooling performance		40 °C below ambient temperature
General specification		
Power supply		DC 12 V
Power consumption		TBD
Temperature		Operating temperature –20 to 60 °C, storage temperature –40 to 85 °C
Humidity		20%–80%, no condensation
Size		68 mm × 68 mm × 90 mm
Weight		TBD
Lens mount		M42 mount
Software		EHDview / SDK

*1: LG: CDS-OFF, DeNoise-ON; MG: CDS-ON, DeNoise-OFF; HG: CDS-ON, DeNoise-OFF.

4.1.4 EHD1302KMB-U200

Table 4-4 EHD1302KMB-U200 camera specifications

Parameter	Model	SWIR1302KMB-U200 1.3M pixels 1.5" InGaAs USB industrial camera
Camera Parameters		
Sensor model		InGaAs sensor 1280×1024
Sensor Type		InGaAs CMOS
Spectral Range		900nm-1700nm
Pixel size		15 μm x 15 μm
Sensor size		1.5"
ADC		14 Bit
Frame rate		200fps@1280×1024
Image Buffer		512MByte
QE		≥70@1.55μm
Conversion Gain		1μV/e- (LG), 16μV/e- (MG), 53.3μV/e- (HG)
Dynamic range		70.59dB(LG), 67.96dB(MG), 47.98dB(HG) *1 (Only reference)
Readout Noise		586.82e(LG), 35.05e(MG), 68.44e(HG) (Only reference)
Full Well		1.9Me- (LG), 118.75Ke- (MG), 33.75Ke- (HG) *1
SNRmax		62.98dB(LG), 49.43dB(MG), 42.34dB(HG) (Only reference)
Dark current		30fa@0.1V&18°C (Only reference)
Exposure time		16μs-1sec
Shutter		Global shutter
Data interface		USB3
Digital I/O		One optical-coupling isolated input, one optical-coupling isolated output, two non-isolated input and output
Data Format		Mono 8 / Mono 14 / Packet12
Cooling performance		40°C below ambient temperature
General specification		
Power supply		12V Power adapter
Power consumption		8.4W(TEC OFF) / <16W(TEC ON)
Temperature		Working temperature -30~60°C, storage temperature -40~85°C
Humidity		20%-80%, no condensation
Size		68mm×68mm×89.8mm
Weight		485g
Lens mount		M42
Software		EHDview/ SDK

*1: LG: CDS-OFF, DeNoise-ON; MG: CDS-ON, DeNoise-OFF; HG: CDS-ON, DeNoise-OFF.

4.1.5 EHD1302KMB-10G

Table 4-5 EHD1302KMB-10G camera specifications

Parameter	Model
	SWIR1302KMB-10G 1.3Mpixels 1.5" InGaAs 10GigE industrial camera
Camera Parameters	
Sensor model	InGaAs sensor 1280×1024
Sensor Type	InGaAs CMOS
Spectral Range	900nm-1700nm
Pixel size	15 μm x 15 μm
Sensor size	1.5"
ADC	14 Bit
Frame rate	200fps@1280×1024
Image Buffer	512MByte
QE	≥70@1.55μm
Conversion Gain	1μV/e- (LG), 16μV/e- (MG), 53.3μV/e- (HG)
Dynamic range	69.2dB(LG), 63.2dB(MG), 57.4dB(HG) *1 (Only reference)
Readout Noise	1.3DN(LG), 2.7DN(MG), 5.0DN(HG) (Only reference)
Full Well	1.9Me- (LG), 118.75Ke- (MG), 33.75Ke-(HG) *1
SNRmax	65.4dB(LG), 48.5dB(MG), 40.7dB(HG) (Only reference)
Dark current	30fa@0.1V&18°C (Only reference)
Exposure time	25μs-5sec
Shutter	Global shutter
Data interface	10G
Digital I/O	One optical-coupling isolated input, one optical-coupling isolated output, two non-isolated input and output
Data Format	Mono 8 / Mono 14
Cooling performance	40°C below ambient temperature
General specification	
Power supply	12V Power adapter
Power consumption	8.4W(TEC OFF)/ <16W(TEC ON)
Temperature	Working temperature -30~60°C, storage temperature -40~85°C
Humidity	20%-80%, no condensation
Size	68mm×68mm×89.8mm
Weight	485g
Lens mount	M42
Software	EHDview/ SDK

*1: LG: CDS-OFF, DeNoise-ON; MG: CDS-ON, DeNoise-OFF; HG: CDS-ON, DeNoise-OFF.

4.1.6 EHD1302KMA-CL200 InGaAs sensor

Table 4-6 EHD1302KMA-CL200 camera specifications

Parameter	Model
	SWIR1302KMA-CL200 1.3Mpixels 1.5" InGaAs CameraLink industrial camera
Camera Parameters	
Sensor model	InGaAs sensor 1280×1024
Sensor Type	InGaAs CMOS
Spectral Range	900nm-1700nm
Pixel size	15 μm x 15 μm
Sensor size	1.5"
ADC	14 Bit
Frame rate	200fps@1280×1024
Image Buffer	512MByte
QE	≥70@1.55μm
Conversion Gain	1μV/e- (LG), 16μV/e- (MG), 53.3μV/e- (HG)
Dynamic range	69.2dB(LG), 63.2dB(MG), 57.4dB(HG) *1 (Only reference)
Readout Noise	1.3DN(LG), 2.7DN(MG), 5.0DN(HG) (Only reference)
Full Well	1.9Me- (LG), 118.75Ke- (MG), 33.75Ke-(HG) *1
SNRmax	65.4dB(LG), 48.5dB(MG), 40.7dB(HG) (Only reference)
Dark current	30fa@0.1V&18°C (Only reference)
Exposure time	16μs-1sec
Shutter	Global shutter
Data interface	CameraLink Full
Digital I/O	One optical-coupling isolated input, one optical-coupling isolated output
Data Format	Mono 14
Cooling performance	40°C below ambient temperature
Camera type	Nationally produced devices
General specification	
Power supply	12V Power adapter
Power consumption	8.4W(TEC OFF)/ <16W(TEC ON)
Temperature	Working temperature -30~60°C, storage temperature -40~85°C
Humidity	20%-80%, no condensation
Size	68mm×68mm×89.8mm
Weight	485g
Lens mount	M42
Software	Provide SDK development kit and CL View software based on Delsa acquisition card

*1: LG: CDS-OFF, DeNoise-ON; MG: CDS-ON, DeNoise-OFF; HG: CDS-ON, DeNoise-OFF.

4.1.7 EHD1302KMB-CL200

Table 4-7 EHD1302KMB-CL200 camera specifications

Parameter	Model	SWIR1302KMB-CL200
		1.3Mpixels 1.5" InGaAs CameraLink industrial camera
Camera Parameters		
Sensor model		InGaAs sensor 1280×1024
Sensor Type		InGaAs CMOS
Spectral Range		900nm-1700nm
Pixel size		15 μm x 15 μm
Sensor size		1.5"
ADC		14 Bit
Frame rate		200fps@1280×1024
Image Buffer		512MByte
QE		≥70@1.55μm
Conversion Gain		1μV/e- (LG), 16μV/e- (MG), 53.3μV/e- (HG)
Dynamic range		69.2dB(LG), 63.2dB(MG), 57.4dB(HG) *1 (Only reference)
Readout Noise		1.3DN(LG), 2.7DN(MG), 5.0DN(HG) (Only reference)
Full Well		1.9Me- (LG), 118.75Ke- (MG), 33.75Ke- (HG) *1
SNRmax		65.4dB(LG), 48.5dB(MG), 40.7dB(HG) (Only reference)
Dark current		30fa@0.1V&18°C (Only reference)
Exposure time		16μs-1sec
Shutter		Global shutter
Data interface		CameraLink Full
Digital I/O		One optical-coupling isolated input, one optical-coupling isolated output
Data Format		Mono 14
Cooling performance		40°C below ambient temperature
Camera type		High performance
General specification		
Power supply		12V Power adapter
Power consumption		8.4W(TEC OFF)/ <16W(TEC ON)
Temperature		Working temperature -30~60°C, storage temperature -40~85°C
Humidity		20%-80%, no condensation
Size		68mm×68mm×89.8mm
Weight		485g
Lens mount		M42
Software		Provide SDK development kit and CL View software based on Delsa acquisition card

*1: LG: CDS-OFF, DeNoise-ON; MG: CDS-ON, DeNoise-OFF; HG: CDS-ON, DeNoise-OFF.

4.1.8 EHD1302 QE Curve

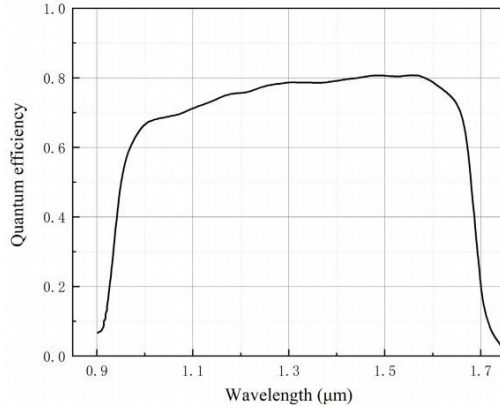

Figure 4-1 EHD1302 QE Curve

4.1.9 EHD1302 Frame rate and ROI frame rate

The camera support hardware ROI, the smaller the ROI size, the faster the frame rate

Table 4-8 CL200 ROI typical frame rate

X Size	Y Size	FPS
1280	1024	207
1280	512	413
640	512	693
320	256	2057
200	200	3206

Table 4-9 U200 ROI typical frame rate

X Size	Y Size	FPS
1280	1024	207
1280	512	413
640	512	693
320	256	2057
200	200	3206

Table 4-10 10G ROI typical frame rate

X Size	Y Size	FPS
1280	1024	207
1280	512	413
640	512	693
320	256	2057
200	200	3206

4.2 SWIR 900-1700 0.33MP 15um InGaAs sensor (17)

4.2.1 EHD339KMB-CL700

Table 4-11 EHD339KMB-CL700 camera specification

Parameter	Model
	SWIR339KMB-CL700 0.33Mpixels 3/4" InGaAs CameraLink industrial camera
Camera Parameters	
Sensor model	InGaAs sensor 640×512
Sensor type	InGaAs CMOS
Spectral range	900nm - 1700nm
pixel size	15 μm x 15 μm
Target size	3/4"
ADC	14-bit
Frame Rate & Resolution	724fps@640 × 512
Memory	512MByte
QE	75%@ 1350nm
Conversion gain	970.01e-/DN(LG), 18.02e-/DN(MG), 3.31e-/DN (HG)
Dynamic Range	70.59dB(LG), 67.96dB(MG), 47.98dB(HG) *1
Read noise	586.82e(LG), 35.05e(MG), 68.44e(HG)
Full well charge	1986.43 ke ⁻ (LG) , 87.65 ke ⁻ , (MG) , 17.15 ke ⁻ (HG) *1
Maximum SNR	62.98dB(LG), 49.43dB(MG), 42.34dB(HG)
Dark current	30fa@0.1V&18°C
Exposure time range	16μs~1s
Shutter mode	Global shutter
Data interface	CameraLink Full
Digital I/O	1 optocoupler isolated input, 1 optocoupler isolated output
Data Format	Mono 12 / Mono 14
Cooling temperature difference	40°C below ambient temperature
Camera type	High performance
General parameters	
Power supply	DC12V power supply
Power consumption	8.4W (TEC OFF) / <16W (TEC ON)
Temperature	Working temperature -30 ~ 60 °C, storage temperature - 40 ~ 85 °C
Humidity	20%-80% , non-condensing
Size	68mm×68mm×90.3mm
Weight	485g
Lens mount	C-mount interface
Software	Provide SDK development kit and CL View software based on Delsa acquisition card

*1: LG: CDS-OFF, DeNoise-ON; MG: CDS-ON, DeNoise-OFF; HG: CDS-ON, DeNoise-OFF.

4.2.2 EHD339KMB-CL700-H

Table 4-12 EHD339KMB-CL700-H camera specification

Parameter	Model
	SWIR339KMB-CL700-H 0.33M pixels 3/4" InGaAs CameraLink industrial camera
Camera Parameters	
Sensor model	InGaAs sensor 640×512
Sensor type	InGaAs CMOS
Spectral range	900nm - 1700nm
pixel size	15 μm x 15 μm
Target size	3/4"
ADC	16-bit
Frame Rate & Resolution	724@640×512(16bit)
Memory	512MByte
QE	75%@ 1350nm
Conversion gain	970.01e-/DN(LG), 18.02e-/DN(MG), 3.31e-/DN (HG)
Dynamic Range	70.6dB(LG), 63.2dB(MG), 57.4dB(HG) *1
Read noise	1.3DN(LG), 2.7DN(MG), 5.0DN(HG)
Full well charge	3.5Me(LG), 70Ke(MG), 12Ke(HG) *1
Maximum SNR	65.4dB(LG), 48.5dB(MG), 40.7dB(HG)
Dark current	30fa@0.1V&18°C
Exposure time range	16μs~1s
Shutter mode	Global shutter
Data interface	CameraLink Full
Digital I/O	1 optocoupler isolated input, 1 optocoupler isolated output
Data Format	Mono 12 / Mono 14 / Mono 16
Cooling temperature difference	40°C below ambient temperature
Camera type	High performance
General parameters	
Power supply	DC12V power supply
Power consumption	8.4W (TEC OFF) / <16W (TEC ON)
Temperature	Working temperature -30 ~ 60 °C, storage temperature - 40 ~ 85 °C
Humidity	20%-80% , non-condensing
Size	68mm×68mm×90.3mm
Weight	485g
Lens mount	C-mount interface
Software	Provide SDK development kit and CL View software based on Delsa acquisition card

*1: LG: CDS-OFF, DeNoise-ON; MG: CDS-ON, DeNoise-OFF; HG: CDS-ON, DeNoise-OFF.

4.2.3 EHD331KMA-CL1000

Table 4-13 EHD331KMA-CL1000 camera specification

Parameter	Model
	SWIR331KMA-CL1000 0.33M pixels 3/4" InGaAs CameraLink industrial camera
Camera Parameters	
Sensor model	InGaAs sensor 640×512
Sensor type	InGaAs CMOS
Spectral range	900nm - 1700nm
pixel size	15 μm x 15 μm
Target size	3/4"
ADC	14-bit
Frame Rate & Resolution	1000fps@640 × 512
Memory	512MByte
QE	75%@ 1350nm
Conversion gain	970.01e-/DN(LG), 18.02e-/DN(MG), 3.31e-/DN (HG)
Dynamic Range	69.2dB(LG), 63.2dB(MG), 57.4dB(HG) *1
Read noise	1.3DN(LG), 2.7DN(MG), 5.0DN(HG)
Full well charge	3.5Me(LG), 70Ke(MG), 12Ke(HG) *1
Maximum SNR	65.4dB(LG), 48.5dB(MG), 40.7dB(HG)
Dark current	30fa@0.1V&18°C
Exposure time range	16μs~1s
Shutter mode	Global shutter
Data interface	CameraLink Full
Digital I/O	1 optocoupler isolated input, 1 optocoupler isolated output
Data Format	Mono 12 / Mono 14
Cooling temperature difference	40°C below ambient temperature
Camera type	Nationally produced devices
General parameters	
Power supply	DC12V power supply
Power consumption	8.4W (TEC OFF) / <16W (TEC ON)
Temperature	Working temperature -30 ~ 60 °C, storage temperature - 40 ~ 85 °C
Humidity	20%-80% , non-condensing
Size	68mm×68mm×90.3mm
Weight	485g
Lens mount	C-mount interface
Software	Provide SDK development kit and CL View software based on Delsa acquisition card

*1: LG: CDS-OFF, DeNoise-ON; MG: CDS-ON, DeNoise-OFF; HG: CDS-ON, DeNoise-OFF.

4.2.4 EHD331KMA-CL700

Table 4-14 EHD331KMA-CL700 camera specification

Parameter	Model	SWIR331KMA-CL700
		0.33M pixels 3/4" InGaAs CameraLink industrial camera
Camera Parameters		
Sensor model		InGaAs sensor 640×512
Sensor type		InGaAs CMOS
Spectral range		900nm - 1700nm
pixel size		15 μm x 15 μm
Target size		3/4"
ADC		14-bit
Frame Rate & Resolution		724fps@640 × 512
Memory		512MByte
QE		75%@ 1350nm
Conversion gain		970.01e-/DN(LG), 18.02e-/DN(MG), 3.31e-/DN (HG)
Dynamic Range		69.2dB(LG), 63.2dB(MG), 57.4dB(HG) *1
Read noise		1.3DN(LG), 2.7DN(MG), 5.0DN(HG)
Full well charge		3.5Me(LG), 70Ke(MG), 12Ke(HG) *1
Maximum SNR		65.4dB(LG), 48.5dB(MG), 40.7dB(HG)
Dark current		30fa@0.1V&18°C
Exposure time range		16μs~1s
Shutter mode		Global shutter
Data interface		CameraLink Full
Digital I/O		1 optocoupler isolated input, 1 optocoupler isolated output
Data Format		Mono 12 / Mono 14
Cooling temperature difference		40°C below ambient temperature
Camera type		Nationally produced devices
General parameters		
Power supply		DC12V power supply
Power consumption		8.4W (TEC OFF) / <16W (TEC ON)
Temperature		Working temperature -30 ~ 60 °C, storage temperature - 40 ~ 85 °C
Humidity		20%-80% , non-condensing
Size		68mm×68mm×90.3mm
Weight		485g
Lens mount		C-mount interface
Software		Provide SDK development kit and CL View software based on Delsa acquisition card

*1: LG: CDS-OFF, DeNoise-ON; MG: CDS-ON, DeNoise-OFF; HG: CDS-ON, DeNoise-OFF.

4.2.5 EHD331KMA-CL500

Table 4-15 EHD331KMA-CL500 camera specification

Parameter	Model	SWIR331KMA-CL500
		0.33M pixels 3/4" InGaAs CameraLink industrial camera
Camera Parameters		
Sensor model		InGaAs sensor 640×512
Sensor type		InGaAs CMOS
Spectral range		900nm - 1700nm
pixel size		15 μm x 15 μm
Target size		3/4"
ADC		14-bit
Frame Rate & Resolution		517fps@640 × 512
Memory		512MByte
QE		75%@ 1350nm
Conversion gain		970.01e-/DN(LG), 18.02e-/DN(MG), 3.31e-/DN (HG)
Dynamic Range		69.2dB(LG), 63.2dB(MG), 57.4dB(HG) *1
Read noise		1.3DN(LG), 2.7DN(MG), 5.0DN(HG)
Full well charge		3.5Me(LG), 70Ke(MG), 12Ke(HG) *1
Maximum SNR		65.4dB(LG), 48.5dB(MG), 40.7dB(HG)
Dark current		30fa@0.1V&18°C
Exposure time range		16μs~1s
Shutter mode		Global shutter
Data interface		CameraLink Full
Digital I/O		1 optocoupler isolated input, 1 optocoupler isolated output
Data Format		Mono 12 / Mono 14
Cooling temperature difference		40°C below ambient temperature
Camera type		Nationally produced devices
General parameters		
Power supply		DC12V power supply
Power consumption		8.4W (TEC OFF) / <16W (TEC ON)
Temperature		Working temperature -30 ~ 60 °C, storage temperature - 40 ~ 85 °C
Humidity		20%-80% , non-condensing
Size		68mm×68mm×90.3mm
Weight		485g
Lens mount		C-mount interface
Software		Provide SDK development kit and CL View software based on Delsa acquisition card

*1: LG: CDS-OFF, DeNoise-ON; MG: CDS-ON, DeNoise-OFF; HG: CDS-ON, DeNoise-OFF.

4.2.6 EHD331KMB-CL1000

Table 4-16 EHD331KMB-CL1000 camera specification

Parameter	Model
	SWIR331KMB-CL1000 0.33M pixels 3/4" InGaAs CameraLink industrial camera
Camera Parameters	
Sensor model	InGaAs sensor 640×512
Sensor type	InGaAs CMOS
Spectral range	900nm - 1700nm
pixel size	15 μm x 15 μm
Target size	3/4"
ADC	14-bit
Frame Rate & Resolution	1000fps@640 × 512
Memory	512MByte
QE	75%@ 1350nm
Conversion gain	970.01e-/DN(LG), 18.02e-/DN(MG), 3.31e-/DN (HG)
Dynamic Range	69.2dB(LG), 63.2dB(MG), 57.4dB(HG) *1
Read noise	1.3DN(LG), 2.7DN(MG), 5.0DN(HG)
Full well charge	3.5Me(LG), 70Ke(MG), 12Ke(HG) *1
Maximum SNR	65.4dB(LG), 48.5dB(MG), 40.7dB(HG)
Dark current	30fa@0.1V&18°C
Exposure time range	16μs~1s
Shutter mode	Global shutter
Data interface	CameraLink Full
Digital I/O	1 optocoupler isolated input, 1 optocoupler isolated output
Data Format	Mono 12 / Mono 14
Cooling temperature difference	40°C below ambient temperature
Camera type	High performance
General parameters	
Power supply	DC12V power supply
Power consumption	8.4W (TEC OFF) / <16W (TEC ON)
Temperature	Working temperature -30 ~ 60 °C, storage temperature - 40 ~ 85 °C
Humidity	20%-80% , non-condensing
Size	68mm×68mm×90.3mm
Weight	485g
Lens mount	C-mount interface
Software	Provide SDK development kit and CL View software based on Delsa acquisition card

*1: LG: CDS-OFF, DeNoise-ON; MG: CDS-ON, DeNoise-OFF; HG: CDS-ON, DeNoise-OFF.

4.2.7 EHD331KMB-CL700

Table 4-17 EHD331KMB-CL700 camera specification

Parameter	Model	SWIR331KMB-CL700
		0.33M pixels 3/4" InGaAs CameraLink industrial camera
Camera Parameters		
Sensor model		InGaAs sensor 640×512
Sensor type		InGaAs CMOS
Spectral range		900nm - 1700nm
pixel size		15 μm x 15 μm
Target size		3/4"
ADC		14-bit
Frame Rate & Resolution		724fps@640 × 512
Memory		512MByte
QE		75%@ 1350nm
Conversion gain		970.01e-/DN(LG), 18.02e-/DN(MG), 3.31e-/DN (HG)
Dynamic Range		69.2dB(LG), 63.2dB(MG), 57.4dB(HG) *1
Read noise		1.3DN(LG), 2.7DN(MG), 5.0DN(HG)
Full well charge		3.5Me(LG), 70Ke(MG), 12Ke(HG) *1
Maximum SNR		65.4dB(LG), 48.5dB(MG), 40.7dB(HG)
Dark current		30fa@0.1V&18°C
Exposure time range		16μs~1s
Shutter mode		Global shutter
Data interface		CameraLink Full
Digital I/O		1 optocoupler isolated input, 1 optocoupler isolated output
Data Format		Mono 12 / Mono 14
Cooling temperature difference		40°C below ambient temperature
Camera type		High performance
General parameters		
Power supply		DC12V power supply
Power consumption		8.4W (TEC OFF) / <16W (TEC ON)
Temperature		Working temperature -30 ~ 60 °C, storage temperature - 40 ~ 85 °C
Humidity		20%-80% , non-condensing
Size		68mm×68mm×90.3mm
Weight		485g
Lens mount		C-mount interface
Software		Provide SDK development kit and CL View software based on Delsa acquisition card

*1: LG: CDS-OFF, DeNoise-ON; MG: CDS-ON, DeNoise-OFF; HG: CDS-ON, DeNoise-OFF.

4.2.8 EHD331KMB-CL500

Table 4-18 EHD331KMB-CL500 camera specification

Parameter	Model	SWIR331KMB-CL500
		0.33M pixels 3/4" InGaAs CameraLink industrial camera
Camera Parameters		
Sensor model		InGaAs sensor 640×512
Sensor type		InGaAs CMOS
Spectral range		900nm - 1700nm
pixel size		15 μm x 15 μm
Target size		3/4"
ADC		14-bit
Frame Rate & Resolution		517fps@640 × 512
Memory		512MByte
QE		75%@ 1350nm
Conversion gain		970.01e-/DN(LG), 18.02e-/DN(MG), 3.31e-/DN (HG)
Dynamic Range		69.2dB(LG), 63.2dB(MG), 57.4dB(HG) *1
Read noise		1.3DN(LG), 2.7DN(MG), 5.0DN(HG)
Full well charge		3.5Me(LG), 70Ke(MG), 12Ke(HG) *1
Maximum SNR		65.4dB(LG), 48.5dB(MG), 40.7dB(HG)
Dark current		30fa@0.1V&18°C
Exposure time range		16μs~1s
Shutter mode		Global shutter
Data interface		CameraLink Full
Digital I/O		1 optocoupler isolated input, 1 optocoupler isolated output
Data Format		Mono 12 / Mono 14
Cooling temperature difference		40°C below ambient temperature
Camera type		High performance
General parameters		
Power supply		DC12V power supply
Power consumption		8.4W (TEC OFF) / <16W (TEC ON)
Temperature		Working temperature -30 ~ 60 °C, storage temperature - 40 ~ 85 °C
Humidity		20%-80% , non-condensing
Size		68mm×68mm×90.3mm
Weight		485g
Lens mount		C-mount interface
Software		Provide SDK development kit and CL View software based on Delsa acquisition card

*1: LG: CDS-OFF, DeNoise-ON; MG: CDS-ON, DeNoise-OFF; HG: CDS-ON, DeNoise-OFF.

4.2.9 EHD331KMB-G125

Table 4-19 EHD331KMB-G125 camera specification

Parameter	Model
	SWIR331KMB-G125 0.33M pixels 3/4" InGaAs GigE camera
Camera Parameters	
Sensor model	InGaAs sensor
Sensor type	InGaAs CMOS
Spectral range	900nm - 1700nm
pixel size	15 μm x 15 μm
Target size	3/4"
ADC	14-bit
Frame Rate & Resolution	8bit: 125@640×512 14bit: 125@640×512
Memory	512MByte
QE	75%@ 1350nm
Conversion gain	138.6e-/ADU(LG), 5.54e-/ADU(MG), 1.2e-/ADU (HG)
Dynamic Range	70.59dB(LG), 67.96dB(MG), 47.98dB(HG) *1
Read noise	586.82e(LG), 35.05e(MG), 68.44e(HG)
Full well charge	1986.43 ke ⁻ (LG) , 87.65 ke ⁻ , (MG) , 17.15 ke ⁻ (HG) *1
Maximum SNR	62.98dB(LG), 49.43dB(MG), 42.34dB(HG)
Dark current	30fa@0.1V&18°C
Exposure time range	25μs~5s
Shutter mode	Global shutter
Data interface	GigE
Digital I/O	1 optocoupler isolated input, 1 optocoupler isolated output, tow non-isolated input and output
Data Format	Mono 8 / Mono 14
Cooling temperature difference	40°C below ambient temperature
General parameters	
Power supply	DC12V power supply
Power consumption	8.4W (TEC OFF) / <16W (TEC ON)
Temperature	Working temperature -30 ~ 60 °C, storage temperature - 40 ~ 85 °C
Humidity	20%-80% , non-condensing
Size	68mm×68mm×90.3mm
Weight	485g
Lens mount	C-mount interface
Software	Provide SDK development kit

*1: LG: CDS-OFF, DeNoise-ON; MG: CDS-ON, DeNoise-OFF; HG: CDS-ON, DeNoise-OFF.

4.2.10 EHD331KMB-G125-C0

Table 4-20 EHD331KMB-G125-C0 camera specification

Parameter	Model
	SWIR331KMB -G125-C0 0.33M pixels 3/4" InGaAs GigE camera
Camera Parameters	
Sensor model	InGaAs sensor
Sensor type	InGaAs CMOS
Spectral range	900nm - 1700nm
pixel size	15 μm x 15 μm
Target size	3/4"
ADC	14-bit
Frame Rate & Resolution	8bit: 125@640×512 14bit: 125@640×512
Memory	512MByte
QE	75%@ 1350nm
Conversion gain	138.6e-/ADU(LG), 5.54e-/ADU(MG), 1.2e-/ADU (HG)
Dynamic Range	70.59dB(LG), 67.96dB(MG), 47.98dB(HG) *1
Read noise	586.82e(LG), 35.05e(MG), 68.44e(HG)
Full well charge	1986.43 ke ⁻ (LG) , 87.65 ke ⁻ , (MG) , 17.15 ke ⁻ (HG) *1
Maximum SNR	62.98dB(LG), 49.43dB(MG), 42.34dB(HG)
Dark current	30fa@0.1V&18°C
Exposure time range	25μs~5s
Shutter mode	Global shutter
Data interface	GigE
Digital I/O	1 optocoupler isolated input, 1 optocoupler isolated output, tow non-isolated input and output
Data Format	Mono 8 / Mono 14
Cooling temperature difference	with support for long exposure mode and deep cooling to -45 degrees.
General parameters	
Power supply	DC12V power supply
Power consumption	8.4W (TEC OFF) / <16W (TEC ON)
Temperature	Working temperature -30 ~ 60 °C, storage temperature - 40 ~ 85 °C
Humidity	20%-80% , non-condensing
Size	68mm×68mm×90.3mm
Weight	485g
Lens mount	C-mount interface
Software	Provide SDK development kit

*1: LG: CDS-OFF, DeNoise-ON; MG: CDS-ON, DeNoise-OFF; HG: CDS-ON, DeNoise-OFF.

4.2.11 EHD331KMB-G350

Table 4-21 EHD331KMB-G350 camera specification

Parameter	Model
	SWIR331KMB-G350 0.33M pixels 3/4" InGaAs GigE camera
Camera Parameters	
Sensor model	InGaAs sensor
Sensor type	InGaAs CMOS
Spectral range	900nm - 1700nm
pixel size	15 μm x 15 μm
Target size	3/4"
ADC	14-bit
Frame Rate & Resolution	8bit: 360@640×512 14bit: 145@640×512
Memory	512MByte
QE	75%@ 1350nm
Conversion gain	138.6e-/ADU(LG), 5.54e-/ADU(MG), 1.2e-/ADU (HG)
Dynamic Range	70.59dB(LG), 67.96dB(MG), 47.98dB(HG) *1
Read noise	586.82e(LG), 35.05e(MG), 68.44e(HG)
Full well charge	1986.43 ke ⁻ (LG), 87.65 ke ⁻ , (MG), 17.15 ke ⁻ (HG) *1
Maximum SNR	62.98dB(LG), 49.43dB(MG), 42.34dB(HG)
Dark current	30fa@0.1V&18°C
Exposure time range	25 μs ~5s
Shutter mode	Global shutter
Data interface	GigE
Digital I/O	1 optocoupler isolated input, 1 optocoupler isolated output, tow non-isolated input and output
Data Format	Mono 8 / Mono 14
Cooling temperature difference	40°C below ambient temperature
General parameters	
Power supply	DC12V power supply
Power consumption	8.4W (TEC OFF) / <16W (TEC ON)
Temperature	Working temperature -30 ~ 60 °C, storage temperature - 40 ~ 85 °C
Humidity	20%-80%, non-condensing
Size	68mm×68mm×90.3mm
Weight	485g
Lens mount	C-mount interface
Software	Provide SDK development kit

*1: LG: CDS-OFF, DeNoise-ON; MG: CDS-ON, DeNoise-OFF; HG: CDS-ON, DeNoise-OFF.

4.2.12 EHD331KMB-G700

Table 4-22 EHD331KMB--G700 camera specification

Parameter	Model
	SWIR331KMB-G700 0.33M pixels 3/4" InGaAs GigE camera
Camera Parameters	
Sensor model	InGaAs sensor
Sensor type	InGaAs CMOS
Spectral range	900nm - 1700nm
pixel size	15 μ m x 15 μ m
Target size	3/4"
ADC	14-bit
Frame Rate & Resolution	8bit: 360@640×512; 700@320×256 14bit: 180@640×512 ROI1-5: Detailed parameters are shown in Table 7 of 2.4 Frame Rate and ROI
Memory	512MByte
QE	75%@ 1350nm
Conversion gain	138.6e-/ADU(LG), 5.54e-/ADU(MG), 1.2e-/ADU (HG)
Dynamic Range	70.59dB(LG), 67.96dB(MG), 47.98dB(HG) *1
Read noise	586.82e(LG), 35.05e(MG), 68.44e(HG)
Full well charge	1986.43 ke ⁻ (LG) , 87.65 ke ⁻ , (MG) , 17.15 ke ⁻ (HG) *1
Maximum SNR	62.98dB(LG), 49.43dB(MG), 42.34dB(HG)
Dark current	30fa@0.1V&18°C
Exposure time range	25 μ s~5s
Shutter mode	Global shutter
Data interface	GigE
Digital I/O	1 optocoupler isolated input, 1 optocoupler isolated output, tow non-isolated input and output
Data Format	Mono 8 / Mono 14
Cooling temperature difference	40°C below ambient temperature
General parameters	
Power supply	DC12V power supply
Power consumption	8.4W (TEC OFF) / <16W (TEC ON)
Temperature	Working temperature -30 ~ 60 °C, storage temperature - 40 ~ 85 °C
Humidity	20%-80% , non-condensing
Size	68mm×68mm×90.3mm
Weight	485g
Lens mount	C-mount interface
Software	Provide SDK development kit

*1: LG: CDS-OFF, DeNoise-ON; MG: CDS-ON, DeNoise-OFF; HG: CDS-ON, DeNoise-OFF.

4.2.13 EHD331KMB-10G

Table 4-23 EHD331KMB-10G camera specification

Parameter	Model
	SWIR331KMB-10G 0.33Mpixels3/4" InGaAs 10GigE camera
Camera Parameters	
Sensor model	InGaAs sensor 640×512
Sensor type	InGaAs CMOS
Spectral range	900nm - 1700nm
pixel size	15 μm x 15 μm
Target size	3/4"
ADC	14-bit
Frame Rate & Resolution	8bit: 724@640×512 14bit: 724@640×512
Memory	512MByte
QE	75%@ 1350nm
Conversion gain	138.6e-/ADU(LG), 5.54e-/ADU(MG), 1.2e-/ADU (HG)
Dynamic Range	70.59dB(LG), 67.96dB(MG), 47.98dB(HG) *1
Read noise	586.82e(LG), 35.05e(MG), 68.44e(HG)
Full well charge	1986.43 ke ⁻ (LG) , 87.65 ke ⁻ , (MG) , 17.15 ke ⁻ (HG) *1
Maximum SNR	62.98dB(LG), 49.43dB(MG), 42.34dB(HG)
Dark current	30fa@0.1V&18°C
Exposure time range	25μs~5s
Shutter mode	Global shutter
Data interface	10G
Digital I/O	1 optocoupler isolated input, 1 optocoupler isolated output, tow non-isolated input and output
Data Format	Mono 8 / Mono 14
Cooling temperature difference	40°C below ambient temperature
General parameters	
Power supply	DC12V power supply
Power consumption	8.4W (TEC OFF) / <16W (TEC ON)
Temperature	Working temperature -30 ~ 60 °C, storage temperature - 40 ~ 85 °C
Humidity	20%-80% , non-condensing
Size	68mm×68mm×90.3mm
Weight	485g
Lens mount	C-mount interface
Software	Provide SDK development kit / EHDview

*1: LG: CDS-OFF, DeNoise-ON; MG: CDS-ON, DeNoise-OFF; HG: CDS-ON, DeNoise-OFF.

4.2.14 EHD331KMB-U700

Table 4-24 EHD331KMB-U700 camera specification

Parameter	Model
	SWIR331KMB-U700 0.33Mpixels 3/4" InGaAs USBcamera
Camera Parameters	
Sensor model	InGaAs sensor 640×512
Sensor type	InGaAs CMOS
Spectral range	900nm - 1700nm
pixel size	15 μm x 15 μm
Target size	3/4"
ADC	14-bit
Frame Rate & Resolution	8bit: 724@640×512 Packet12:724@640×512 14bit:579@640×512
Memory	512MByte
QE	75%@ 1350nm
Conversion gain	138.6e-/ADU(LG), 5.54e-/ADU(MG), 1.2e-/ADU (HG)
Dynamic Range	70.59dB(LG), 67.96dB(MG), 47.98dB(HG) *1
Read noise	586.82e(LG), 35.05e(MG), 68.44e(HG)
Full well charge	1986.43 ke ⁻ (LG) , 87.65 ke ⁻ , (MG) , 17.15 ke ⁻ (HG) *1
Maximum SNR	62.98dB(LG), 49.43dB(MG), 42.34dB(HG)
Dark current	30fa@0.1V&18°C
Exposure time range	16μs~5s
Shutter mode	Global shutter
Data interface	USB3
Digital I/O	1 optocoupler isolated input, 1 optocoupler isolated output, tow non-isolated input and output
Data Format	Mono 8 / Mono 14 / Packet12
Cooling temperature difference	40°C below ambient temperature
General parameters	
Power supply	DC12V power supply
Power consumption	8.4W (TEC OFF) / <16W (TEC ON)
Temperature	Working temperature -30 ~ 60 °C, storage temperature - 40 ~ 85 °C
Humidity	20%-80% , non-condensing
Size	68mm×68mm×90.3mm
Weight	485g
Lens mount	C-mount interface
Software	Provide SDK development kit / EHDview

*1: LG: CDS-OFF, DeNoise-ON; MG: CDS-ON, DeNoise-OFF; HG: CDS-ON, DeNoise-OFF.

4.2.15 EHD331KMB-U700-C0

Table 4-25 EHD331KMB-U700-C0 camera specification

Parameter	Model
	SWIR331KMB-U700-C0 0.33Mpixels 3/4" InGaAs USBcamera
Camera Parameters	
Sensor model	InGaAs sensor 640×512
Sensor type	InGaAs CMOS
Spectral range	900nm - 1700nm
pixel size	15 μm x 15 μm
Target size	3/4"
ADC	14-bit
Frame Rate & Resolution	8bit: 724@640×512 Packet12:724@640×512 14bit:579@640×512
Memory	512MByte
QE	75%@ 1350nm
Conversion gain	138.6e-/ADU(LG), 5.54e-/ADU(MG), 1.2e-/ADU (HG)
Dynamic Range	70.59dB(LG), 67.96dB(MG), 47.98dB(HG) *1
Read noise	586.82e(LG), 35.05e(MG), 68.44e(HG)
Full well charge	1986.43 ke ⁻ (LG) , 87.65 ke ⁻ , (MG) , 17.15 ke ⁻ (HG) *1
Maximum SNR	62.98dB(LG), 49.43dB(MG), 42.34dB(HG)
Dark current	30fa@0.1V&18°C
Exposure time range	16μs~5s
Shutter mode	Global shutter
Data interface	USB3
Digital I/O	1 optocoupler isolated input, 1 optocoupler isolated output, tow non-isolated input and output
Data Format	Mono 8 / Mono 14 / Packet12
Cooling temperature difference	with support for long exposure mode and deep cooling to -45 degrees.
General parameters	
Power supply	DC12V power supply
Power consumption	8.4W (TEC OFF) / <16W (TEC ON)
Temperature	Working temperature -30 ~ 60 °C, storage temperature - 40 ~ 85 °C
Humidity	20%-80% , non-condensing
Size	68mm×68mm×90.3mm
Weight	485g
Lens mount	C-mount interface
Software	Provide SDK development kit / EHDview

*1: LG: CDS-OFF, DeNoise-ON; MG: CDS-ON, DeNoise-OFF; HG: CDS-ON, DeNoise-OFF.

4.2.16 EHD331KMB-UMV

Table 4-26 EHD331KMB-UMV camera specification

Parameter	Model
	SWIR331KMB-UMV 0.33M pixels 3/4" InGaAs USBcamera
Camera Parameters	
Sensor model	InGaAs sensor 640×512
Sensor type	InGaAs CMOS
Spectral range	900nm - 1700nm
pixel size	15 μm x 15 μm
Target size	3/4"
ADC	14-bit
Frame Rate & Resolution	400@640×512
Memory	512MByte
QE	75%@ 1350nm
Conversion gain	138.6e-/ADU(LG), 5.54e-/ADU(MG), 1.2e-/ADU (HG)
Dynamic Range	70.59dB(LG), 67.96dB(MG), 47.98dB(HG) *1
Read noise	586.82e(LG), 35.05e(MG), 68.44e(HG)
Full well charge	1986.43 ke ⁻ (LG) , 87.65 ke ⁻ , (MG) , 17.15 ke ⁻ (HG) *1
Maximum SNR	62.98dB(LG), 49.43dB(MG), 42.34dB(HG)
Dark current	30fa@0.1V&18°C
Exposure time range	16μs~5s
Shutter mode	Global shutter
Data interface	USB3
Digital I/O	1 optocoupler isolated input, 1 optocoupler isolated output, tow non-isolated input and output
Data Format	Mono 8 / Mono 14 / Packet12
Optical filter	400-1800nm(default); 1030-1800nm(optional)
CRA	2.35 Deg
General parameters	
Power supply	12V Power adapter
Power consumption	TBD
Temperature	Working temperature -30 ~ 60 °C, storage temperature - 40 ~ 85 °C
Humidity	20%-80% , non-condensing
Size	45mm×45mm×64.5mm
Weight	TBD
Lens mount	C-mount interface
Software	Provide SDK development kit / EHDview

*1: LG: CDS-OFF, DeNoise-ON; MG: CDS-ON, DeNoise-OFF; HG: CDS-ON, DeNoise-OFF.

4.2.17 EHD331KMB-GMV

Table 4-27 EHD331KMB-GMV camera specification

Parameter	Model
	SWIR331KMB-GMV 0.33Mpixels 3/4" InGaAs GigE camera
Camera Parameters	
Sensor model	InGaAs sensor 640×512
Sensor type	InGaAs CMOS
Spectral range	900nm-1700nm
pixel size	15μm x 15μm
Target size	3/4"
ADC	14bit
Frame Rate & Resolution	8 Bit:335fps@640 x 512 14 Bit:180fps@640 x 512
Memory	512MByte
QE	75%@ 1350nm
Conversion gain	138.6e-/ADU(LG), 5.54e-/ADU(MG), 1.2e-/ADU (HG)
Dynamic Range	70.59dB(LG), 67.96dB(MG), 47.98dB(HG) *1
Read noise	586.82e(LG), 35.05e(MG), 68.44e(HG)
Full well charge	1986.43 ke ⁻ (LG), 87.65 ke ⁻ , (MG), 17.15 ke ⁻ (HG) *1
Maximum SNR	62.98dB(LG), 49.43dB(MG), 42.34dB(HG)
Dark current	30fa@0.1V&18°C
Exposure time range	16μs~5s
Shutter mode	Global shutter
Data interface	GigE
Digital I/O	1 optocoupler isolated input, 1 optocoupler isolated output, tow non-isolated input and output
Data Format	Mono 8 / Mono 14
Optical filter	400-1800nm(default); 1030-1800nm(optional)
CRA	2.35 Deg
General parameters	
Power supply	12V Power adapter
Power consumption	5.8W (TEC OFF) / 6.3W (TEC ON)
Temperature	Working temperature -30 ~ 60 °C, storage temperature - 40 ~ 85 °C
Humidity	20%-80% , non-condensing
Size	45mm×45mm×64.5mm
Weight	TBD
Lens mount	C-mount interface
Software	Provide SDK development kit / EHDview

*1: LG: CDS-OFF, DeNoise-ON; MG: CDS-ON, DeNoise-OFF; HG: CDS-ON, DeNoise-OFF.

4.2.18 EHD331 QE Curve

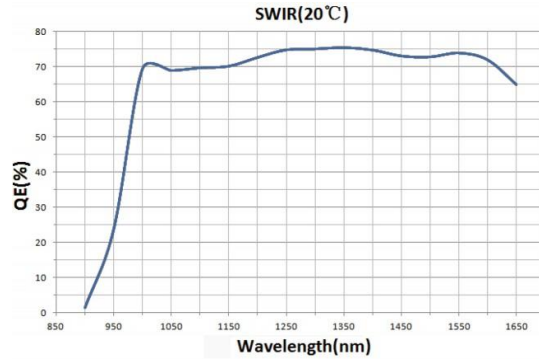

Figure 4-2 EHD331 QE Curve

4.2.19 EHD331 Frame rate and ROI frame rate

The camera support hardware ROI, the smaller the ROI size, the faster the frame rate

Table 4-28 CL1000 ROI typical frame rate

X Size	Y Size	FPS
640	512	1000
640	256	1978
320	256	3040
200	200	4816
112	112	10008

Table 4-29 CL700 ROI typical frame rate

X Size	Y Size	FPS
640	512	724
640	256	1432
320	256	2201
200	200	3487
120	120	6595

Table 4-30 CL500 ROI typical frame rate

X Size	Y Size	FPS
640	512	517
640	256	1023
320	256	1572
200	200	2491
120	120	4774

Table 4-31 GigE700 ROI typical frame rate

X Size	Y Size	FPS
640	512	360
640	256	710
320	256	1424
200	200	2810
120	120	3220

Table 4-32 GigE700 Y direction BIN2-4 Open the rear frame rate

X Size	Y Size	FPS
640	200	8bit:920 14bit:460
640	100	8bit:1800 14bit:920
640	50	8bit:1800 14bit:1800

Table 4-33 GigE125 ROI typical frame rate

X Size	Y Size	FPS
640	512	125
640	256	249
320	256	498
200	200	978
120	120	2460

Table 4-34 GigE350 ROI typical frame rate

X Size	Y Size	FPS
640	512	8bit:358 14bit:140
640	256	8bit:358 14bit:140
320	256	8bit:720 14bit:280
200	200	8bit:1098 14bit:430
120	120	8bit:1421 14bit:557

4.3 SWIR 900-1700 Line Scan Cameras

4.3.1 EHD2048L3A-CL80K

EHD2048L3A-CL80K

Parameter	Model
	SWIR2048L3A-CL80K
2048 Pixel InGaAs Camralink camera	
Camera Parameter	
Sensor model	2048 Line
Sensor Type	InGaAs Zeilensensor (SWIR)
Spectral Range	900nm-1700nm
Pixel Size	12.5μm×12.5μm
Sensor Size	25.6mm
ADC	14 bit
Frame rate	79K@2048*1
Image Buffer	512MByte
QE	70%@1550nm
Gain	6.1 e-/ADU(GAIN =1)
Dynamic range	64.1 dB(GAIN =1)
Readout Noise	60.4e -(GAIN =1)
Full Well	96.4ke-(GAIN =1)
SNRmax	49.8 dB(GAIN =1)
Exposure Time	1us-1s
Shutter Mode	Global Shutter
Data Interface	Cameralink Full
DigitalIO	1 optically isolated input, 1 optically isolated output
Data Format	Mono 14
Cooling performance	40°C below ambient temperature
General Specification	
Power Supply	DC 12VDC
Power consumption	TBD
Temperature	Working temperature -40 ~ 70°C, Storage temperature -40 ~ 70°C
Humidity	20 - 80%, no condensation
Size	68mm×68mm×90.3mm
Weight	485g
Lens mount	M42
Software	SDK based on Dalsa CLView

*1: LG: CDS-OFF, DeNoise-ON; MG: CDS-ON, DeNoise-OFF; HG: CDS-ON, DeNoise-OFF.

4.3.2 EHD2048L3A-CL80K QE Curve

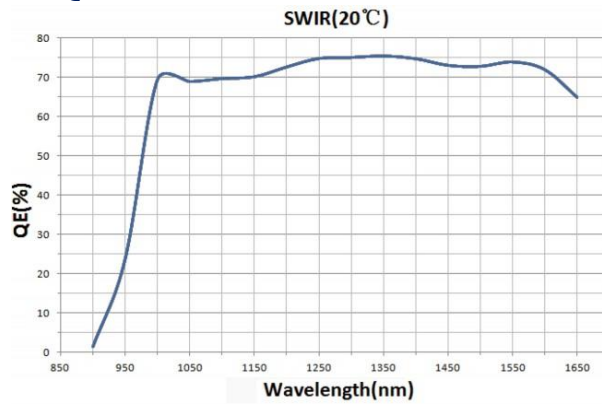

Figure 4-3 EHD2048L3A-CL80K QE Curve

5 SWIR 400-2500 camera model specifications

5.1 SWIR 400-1700 1.3MP 15um (1)

5.1.1 EHD1302KMB-E0417-U200

Table 5-1 EHD1302KMB-E0417-U200 camera specification

Parameter	Model
	SWIR1302KMB-E0417-U200 1.3M pixels 1.5" InGaAs USB industrial camera
Camera Parameters	
Sensor model	1280×1024 sensor
Sensor type	InGaAs CMOS image sensor
Spectral range	400nm - 1700nm
Pixel size	15μm × 15μm
Target size	1.5"
ADC	14-bit
Frame Rate & Resolution	200fps@1280 × 1024
Memory	512MByte
QE	≥70@1.55μm
Conversion gain	1μV/e- (LG), 16μV/e- (MG), 53.3μV/e- (HG)
Dynamic Range	70.59dB (LG), 67.96dB (MG), 47.98dB (HG) *1 (for reference only)
Read noise	586.82e (LG), 35.05e (MG), 68.44e (HG) (for reference only)
Full well charge	1.9Me- (LG), 118.75Ke- (MG), 33.75Ke- (HG) *1
Maximum SNR	62.98dB (LG), 49.43dB (MG), 42.34dB (HG) (for reference only)
Exposure time range	16μs ~ 1s
Shutter mode	Global shutter
Data interface	USB3
Digital I/O	1 optocoupler isolated input, 1 optocoupler isolated output, 2 non-isolated I/O ports
Data Format	Mono 8 / Mono 14 / Packet12
Cooling temperature difference	40°C below ambient temperature
General parameters	
Power supply	DC12V power supply
Power consumption	TBD
Temperature	Working temperature -30 ~ 60°C, storage temperature -40 ~ 85°C
Humidity	20% - 80%, non-condensing
Size	68mm×68mm×89.8mm
Weight	485g
Lens mount	M42
Software	Complete SDK development kit / EHDview

*1: LG: CDS-OFF, DeNoise-ON; MG: CDS-ON, DeNoise-OFF; HG: CDS-ON, DeNoise-OFF.

5.1.2 EHD1302KMB QE Curve

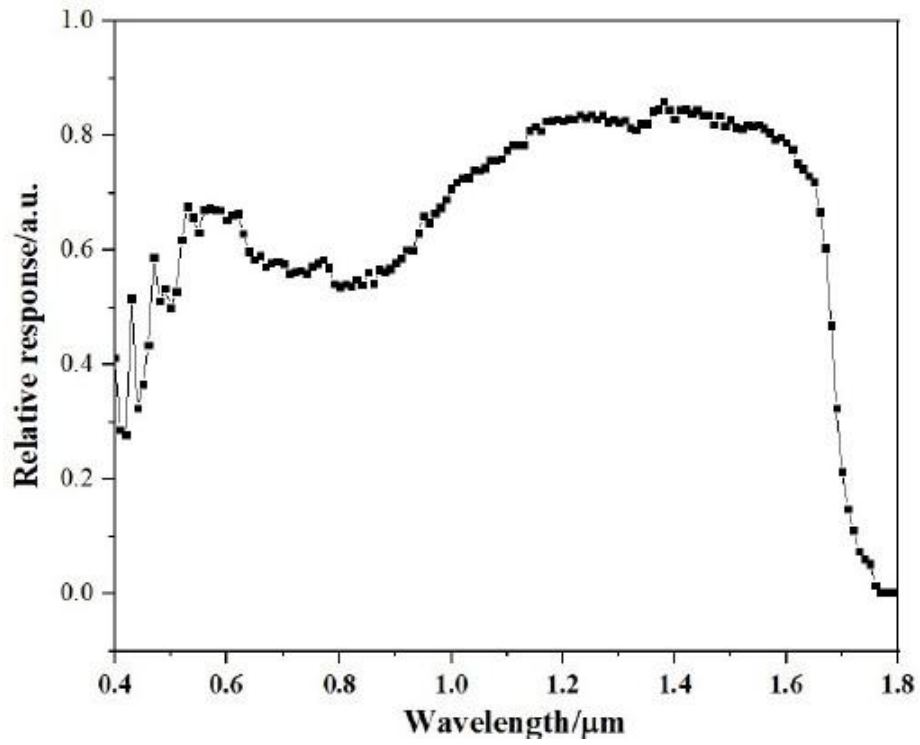

Figure 6 1 EHD1302KMB QE Curve

5.2 SWIR 400-1700 0.33MP 15um(2)

5.2.1 EHD339KMB-E0417-CL700

Table 5-2 EHD339KMB-E0417-CL700 camera specification

Parameter	Model	SWIR339KMB-E0417-CL700
		0.33M pixels 3/4" InGaAs CameraLink camera
Camera Parameters		
Sensor model	InGaAs sensor 640×512	
Sensor type	InGaAs CMOS	
Spectral range	400nm - 1700nm	
pixel size	15 μm x 15 μm	
Target size	3/4"	
ADC	14-bit	
Frame Rate & Resolution	8/12/14bit:240@640×512	
Memory	512MByte	
QE	70%@ 1700nm	
Conversion gain	0.618 e-/ADU (HCG), 3.559 e-/ADU (MCG), 136.52 e-/ADU (LCG)	
Dynamic Range	58.97 dB (HCG), 82.13 dB (MCG), 488.80 dB (LCG) *1 (for reference only)	
Read noise	58.97 e- (HCG), 82.13 e- (MCG), 488.80 e- (LCG) (for reference only)	
Full well charge	9.90 Ke- (HCG), 56.62 Ke- (MCG), 2162.54 Ke- (LCG) *1	
Maximum SNR	39.95 dB (HCG), 47.55 dB (MCG), 63.35 dB (LCG) (for reference only)	
Dark current	<100 fA @ 0.1 V & 18°C (fA = 6250 e-/s)	
Exposure time range	16μs~5s	
Shutter mode	Global shutter	
Data interface	CameraLink	
Digital I/O	1 optocoupler isolated input, 1 optocoupler isolated output, tow non-isolated input and output	
Data Format	Mono 8 / Mono 12 / Mono 14	
Cooling temperature difference	40°C below ambient temperature	
General parameters		
Power supply	DC12V power supply	
Power consumption	8.4W (TEC OFF) / <16W (TEC ON)	
Temperature	Working temperature -30 ~ 60 °C, storage temperature - 40 ~ 85 °C	
Humidity	20%-80% , non-condensing	
Size	68mm×68mm×90.3mm	
Weight	485g	
Lens mount	C-mount interface	
Software	Provide SDK development kit and CL View software based on Delsa acquisition card	

5.2.2 EHD339KMB-E0417-U700

Table 5-3 EHD339KMB-E0417-U700camera specification

Parameter	Model
	SWIR339KMB-E0417-U700 0.33M pixels 3/4" InGaAs USB3.0 camera
Camera Parameters	
Sensor model	InGaAs sensor 640×512
Sensor type	InGaAs CMOS
Spectral range	400nm - 1700nm
pixel size	15 μm x 15 μm
Target size	3/4"
ADC	14-bit
Frame Rate & Resolution	8/12/14bit:240@640×512
Memory	512MByte
QE	70%@ 1700nm
Conversion gain	0.618 e-/ADU (HCG), 3.559 e-/ADU (MCG), 136.52 e-/ADU (LCG)
Dynamic Range	58.97 dB (HCG), 82.13 dB (MCG), 488.80 dB (LCG) *1 (for reference only)
Read noise	58.97 e- (HCG), 82.13 e- (MCG), 488.80 e- (LCG) (for reference only)
Full well charge	9.90 Ke- (HCG), 56.62 Ke- (MCG), 2162.54 Ke- (LCG) *1
Maximum SNR	39.95 dB (HCG), 47.55 dB (MCG), 63.35 dB (LCG) (for reference only)
Dark current	<100 fA @ 0.1 V & 18°C (fA = 6250 e-/s)
Exposure time range	16μs~5s
Shutter mode	Global shutter
Data interface	USB3.0
Digital I/O	1 optocoupler isolated input, 1 optocoupler isolated output, tow non-isolated input and output
Data Format	Mono 8 / Mono 12 / Mono 14
Cooling temperature difference	40°C below ambient temperature
General parameters	
Power supply	DC12V power supply
Power consumption	8.4W (TEC OFF) / <16W (TEC ON)
Temperature	Working temperature -30 ~ 60 °C, storage temperature - 40 ~ 85 °C
Humidity	20%-80% , non-condensing
Size	68mm×68mm×90.3mm
Weight	485g
Lens mount	C-mount interface
Software	Provide SDK development kit and CL View software based on Delsa acquisition card

5.2.3 EHD339KMB-E0417 QE Curve

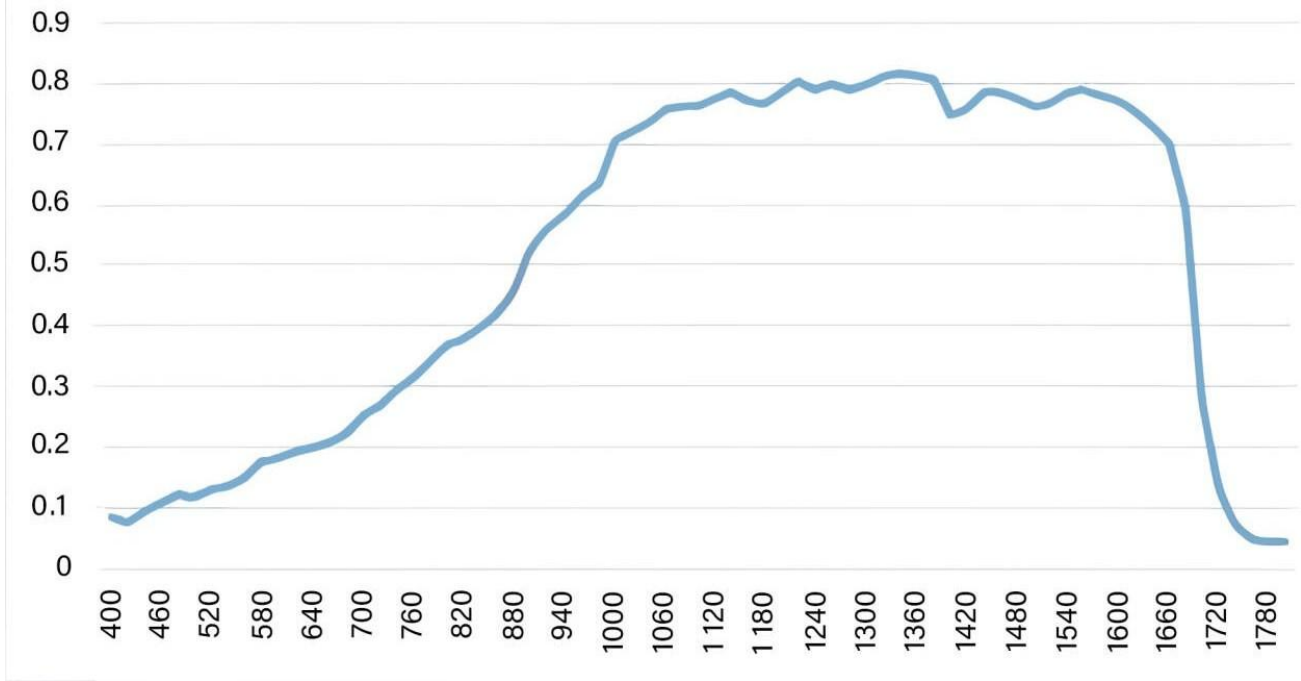

Figure 5-1 EHD339KMB-E0417 QE Curve

5.2.4 SWIR 1000-1900 0.33MP 15um(1)

5.2.5 EHD333KMB-E1019-U240

Table 5-4 EHD333KMB-E1019-U240 camera specification

Parameter	Model
	SWIR333KMB-E1019 -U240 0.33Mpixels3/4" InGaAs USB camera
Camera Parameters	
Sensor model	InGaAs sensor 640×512
Sensor type	InGaAs CMOS
Spectral range	1000nm - 1900nm
pixel size	15 μm x 15 μm
Target size	3/4"
ADC	14-bit
Frame Rate & Resolution	8/12/14bit:240@640×512
Memory	512MByte
QE	70%@ 1700nm
Conversion gain	TBD
Dynamic Range	TBD
Read noise	< 35e ⁻
Full well charge	1.38Me ⁻ (LG), 118Ke ⁻ (MG), 41Ke ⁻ (HG)
Maximum SNR	TBD
Dark current	<100fA@0.1V&18°C (fA=6250e ⁻ /s)
Exposure time range	16μs~5s
Shutter mode	Global shutter
Data interface	USB3
Digital I/O	1 optocoupler isolated input, 1 optocoupler isolated output, tow non-isolated input and output
Data Format	Mono 8 / Mono 12 / Mono 14
Cooling temperature difference	40°C below ambient temperature
General parameters	
Power supply	DC12V power supply
Power consumption	8.4W (TEC OFF) / <16W (TEC ON)
Temperature	Working temperature -30 ~ 60 °C, storage temperature - 40 ~ 85 °C
Humidity	20%-80% , non-condensing
Size	68mm×68mm×90.3mm
Weight	485g
Lens mount	C-mount interface
Software	Provide SDK development kit / EHDview

5.2.6 EHD333KMB-E1019 QE Curve

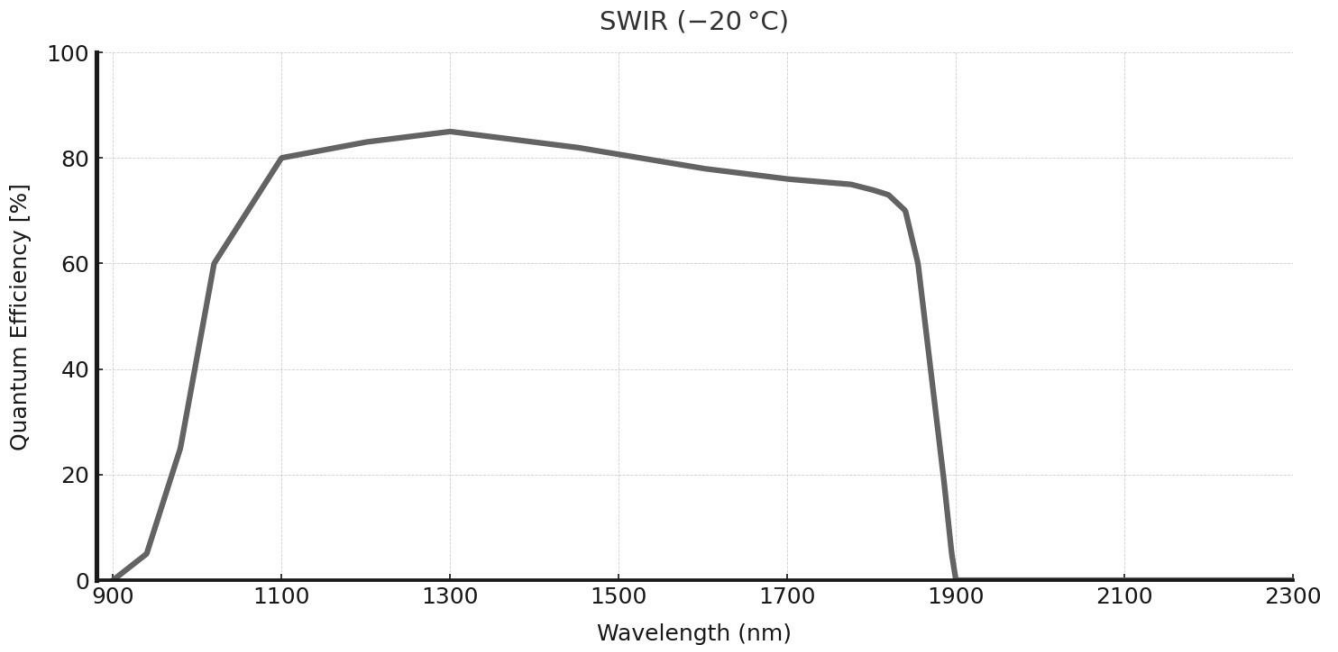

Figure 5-2 5.1.6 EHD333KMB-E1019 QE Curve

5.3 SWIR 1200-2200 0.33MP 15um(1)

5.3.1 EHD333KMB-E1222-U270

Table 5-5 EHD333KMB-E1222-U270 camera specification

Parameter	Model
	SWIR333KMB-E1222 -U240 0.33Mpixels3/4" InGaAs USB camera
Camera Parameters	
Sensor model	InGaAs sensor 640×512
Sensor type	InGaAs CMOS
Spectral range	1200nm - 2200nm
pixel size	15 μm x 15 μm
Target size	3/4"
ADC	14-bit
Frame Rate & Resolution	8/12/14bit:270@640×512
Memory	512MByte
QE	77.8e-/DN(LG), 6.6e-/DN(MG), 2.0e-/DN (HG)
Conversion gain	71.4dB(LG), 63.4dB(MG), 56.2dB(HG) *1
Dynamic Range	< 50e-
Read noise	1.21Me- (LG), 102Ke- (MG), 28Ke-(HG)
Full well charge	60.8dB(LG), 50.1dB(MG), 44.5dB(HG)
Maximum SNR	<25fa@0.1V&18°C; 178K e-/pixel/s
Dark current	77.8e-/DN(LG), 6.6e-/DN(MG), 2.0e-/DN (HG)
Exposure time range	16μs~5s
Shutter mode	Global shutter
Data interface	USB3
Digital I/O	1 optocoupler isolated input, 1 optocoupler isolated output, tow non-isolated input and output
Data Format	Mono 8 / Mono 12 / Mono 14
Cooling temperature difference	70°C below ambient temperature
General parameters	
Power supply	DC12V power supply
Power consumption	8.4W (TEC OFF) / <16W (TEC ON)
Temperature	Working temperature -30 ~ 60 °C, storage temperature - 40 ~ 85 °C
Humidity	20%-80% , non-condensing
Size	68mm×68mm×90.3mm
Weight	485g
Lens mount	C-mount interface
Software	Provide SDK development kit / EHDview

5.3.2 EHD333KMB-E1222-U270 QE Curve

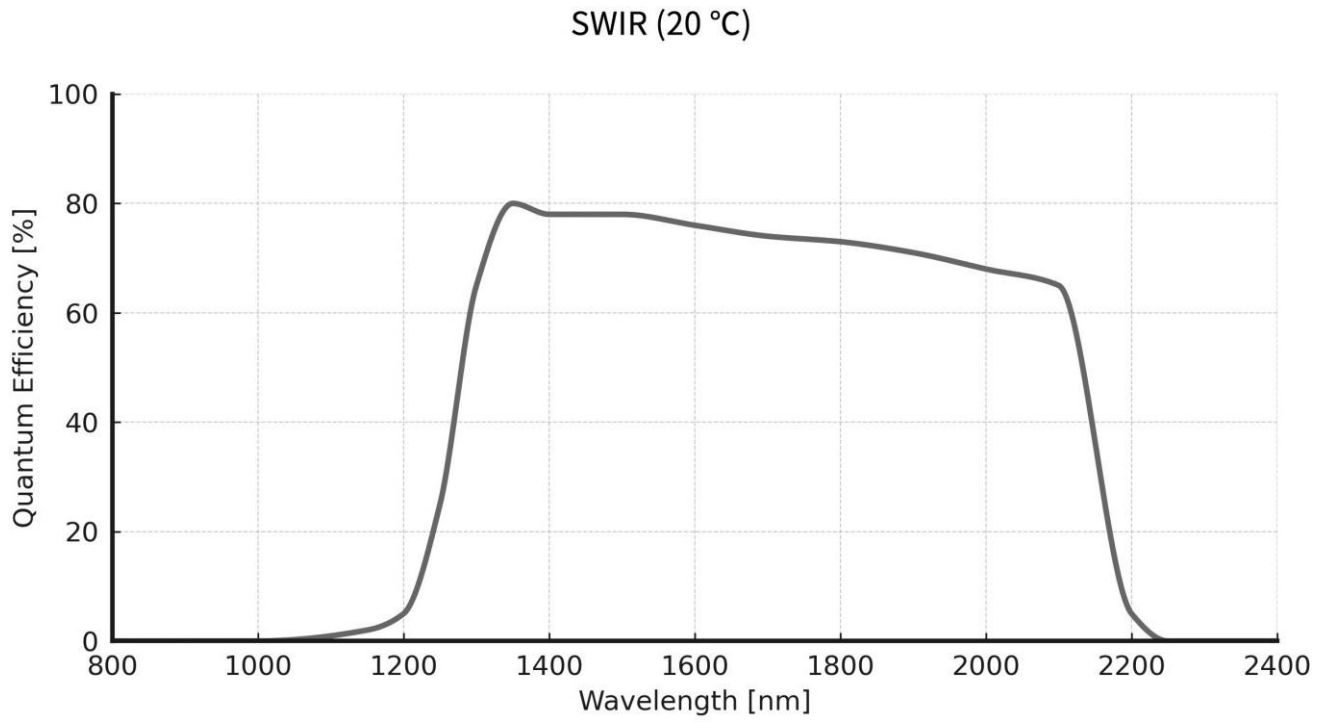

Figure 5-3 EHD333KMB-E1222-U270 QE Curve

6 CQD 300-1700 camera model specifications

6.1 CQD 800-1700 0.33MP 15um(1)

6.1.1 EHD334KMB-U110

Table 6-1 EHD334KMB-U110 camera specification

Parameter	Model
	SWIR334KMB-U110 0.33M pixels 3/4" CQDs USB camera
Camera Parameters	
Sensor model	InGaAs sensor 640×512
Sensor type	CQDs CMOS
Spectral range	800nm - 1700nm
pixel size	15 μm x 15 μm
Target size	3/4"
ADC	14-bit
Frame Rate & Resolution	8/12/14bit:110 @640×512
Memory	512MByte
QE	40%
Conversion gain	45 e-/DN
Dynamic Range	71.6dB
Read noise	< 180e ⁻
Full well charge	690ke ⁻
Maximum SNR	58.4dB
Exposure time range	16μs~5s
Shutter mode	Global shutter
Data interface	USB3.0
Digital I/O	1 optocoupler isolated input, 1 optocoupler isolated output, tow non-isolated input and output
Data Format	Mono 8 / Mono 12 / Mono 14
Cooling temperature difference	40°C below ambient temperature
General parameters	
Power supply	DC12V power supply
Power consumption	8.4W (TEC OFF) / <16W (TEC ON)
Temperature	Working temperature -30 ~ 60 °C, storage temperature - 40 ~ 85 °C
Humidity	20%-80% , non-condensing
Size	68mm×68mm×90.3mm
Weight	485g
Lens mount	C-mount interface
Software	Provide SDK development kit / EHDview

6.2 CQD 400-1700 0.33MP 15um(2)

6.2.1 EHD335KMB-U200

Table 6-2 EHD335KMB-U200camera specification

Parameter	Model
	SWIR335KMB-U200 0.33M pixels 3/4" CQDs USB camera
Camera Parameters	
Sensor model	InGaAs sensor 640×512
Sensor type	CQDs CMOS
Spectral range	400nm-1700nm
pixel size	15 μm x 15 μm
Target size	3/4"
ADC	14-bit
Frame Rate & Resolution	200 @ 640 × 512
Memory	512MByte
QE	40%
Conversion gain	TBD
Dynamic Range	TBD
Read noise	TBD
Full well charge	TBD
Maximum SNR	TBD
Exposure time range	16μs~5s
Shutter mode	Global shutter
Data interface	USB3.0
Digital I/O	1 optocoupler isolated input, 1 optocoupler isolated output, tow non-isolated input and output
Data Format	Mono 8 / Mono 12 / Mono 14
Cooling temperature difference	40°C below ambient temperature
General parameters	
Power supply	DC12V power supply
Power consumption	8.4W (TEC OFF) / <16W (TEC ON)
Temperature	Working temperature -30 ~ 60 °C, storage temperature - 40 ~ 85 °C
Humidity	20%-80% , non-condensing
Size	68mm×68mm×90.3mm
Weight	485g
Lens mount	C-mount interface
Software	Provide SDK development kit / EHDview

6.2.2 EHD334 QE Curve

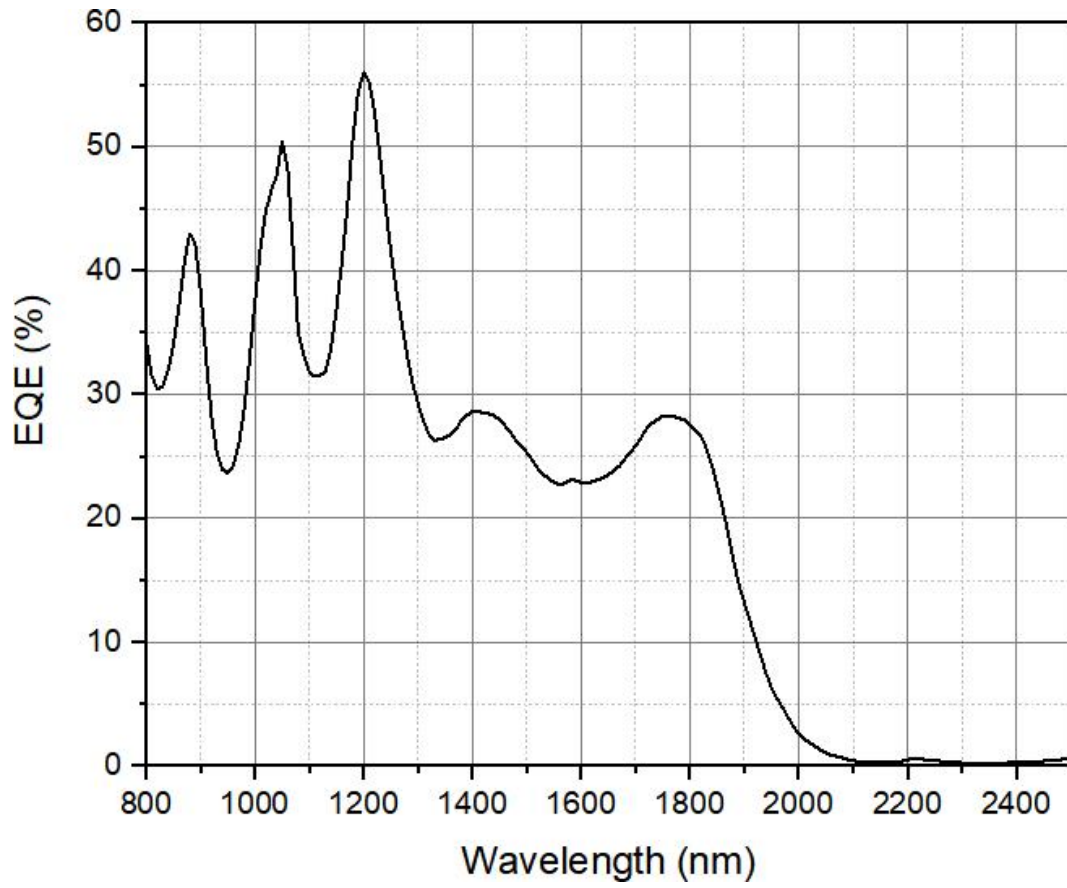

Figure 6-1 EHD334 QE Curve

6.2.3 EHD335KMB-UMV-U200 QE Curve

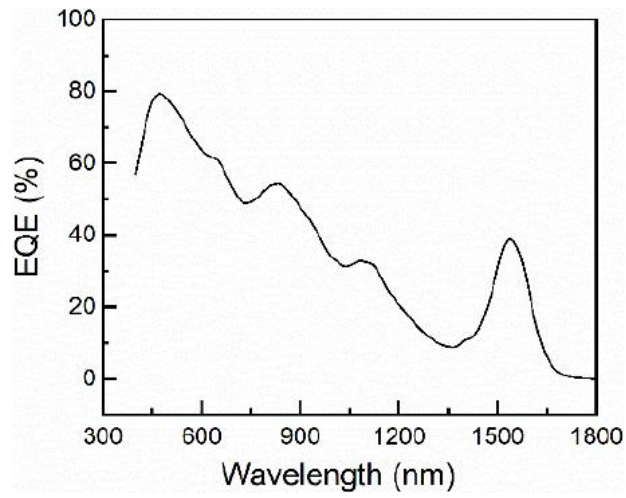

Figure 6-2 EHD335KMB-U200 QE Curve

6.2.4 EHD335KMB-UMV

Table 6-3 EHD335KMB-UMV camera specification

Parameter	Model
	SWIR335KMB-UMV 0.33M pixels 3/4" CQDs USB camera
Camera Parameters	
Sensor model	InGaAs sensor 640×512
Sensor type	CQDs CMOS
Spectral range	400nm-1700nm
pixel size	15 μm x 15 μm
Target size	3/4"
ADC	14-bit
Frame Rate & Resolution	200 @ 640 × 512
Memory	512MByte
QE	40%
Conversion gain	TBD
Dynamic Range	TBD
Read noise	TBD
Full well charge	TBD
Maximum SNR	TBD
Exposure time range	16μs~5s
Shutter mode	Global shutter
Data interface	USB3.0
Digital I/O	1 optocoupler isolated input, 1 optocoupler isolated output, tow non-isolated input and output
Data Format	Mono 8 / Mono 12 / Mono 14
Cooling temperature difference	None
General parameters	
Power supply	DC12V power supply
Power consumption	8.4W (TEC OFF) / <16W (TEC ON)
Temperature	Working temperature -30 ~ 60 °C, storage temperature - 40 ~ 85 °C
Humidity	20%-80% , non-condensing
Size	45mm×45mm×50mm
Weight	TBD
Lens mount	C-mount interface
Software	Provide SDK development kit / EHDview

6.2.5 EHD335KMB-UMV QE Curve

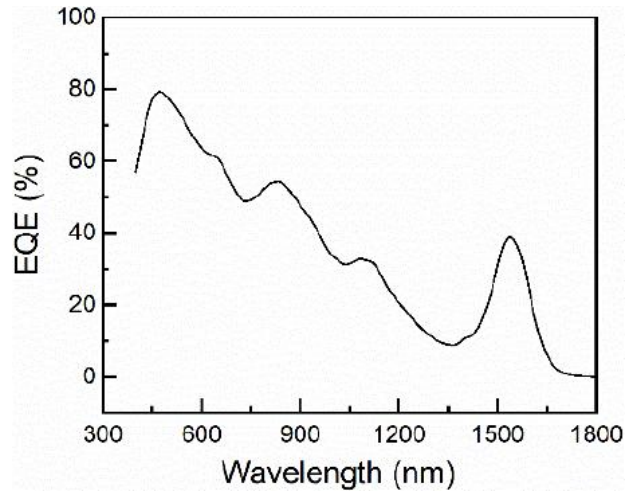

Figure 6-3 EHD335KMB-UMV QE Curve

6.3 CQD 300-1400 0.33MP 15um(1)

6.3.1 EHD336KMB-UMV

Table 6-4 EHD336KMB-UMV camera specification

Parameter	Model
	SWIR336KMB-UMV 0.33M pixels 3/4" CQDs USB camera
Camera Parameters	
Sensor model	InGaAs sensor 640×512
Sensor type	CQDs CMOS
Spectral range	300nm-1400nm
pixel size	15 μm x 15 μm
Target size	3/4"
ADC	14-bit
Frame Rate & Resolution	400 @ 640 × 512
Memory	512MByte
QE	40%
Conversion gain	45 e-/DN
Dynamic Range	66dB
Read noise	TBD
Full well charge	690ke ⁻
Maximum SNR	61.4dB
Exposure time range	16μs~5s
Shutter mode	Global shutter
Data interface	USB3.0
Digital I/O	1 optocoupler isolated input, 1 optocoupler isolated output, tow non-isolated input and output
Data Format	Mono 8 / Mono 12 / Mono 14
Cooling temperature difference	None
General parameters	
Power supply	DC12V power supply
Power consumption	8.4W (TEC OFF) / <16W (TEC ON)
Temperature	Working temperature -30 ~ 60 °C, storage temperature - 40 ~ 85 °C
Humidity	20%-80% , non-condensing
Size	45mm×45mm×50mm
Weight	TBD
Lens mount	C-mount interface
Software	Provide SDK development kit / EHDview

6.3.2 EHD336KMB-UMV QE Curve

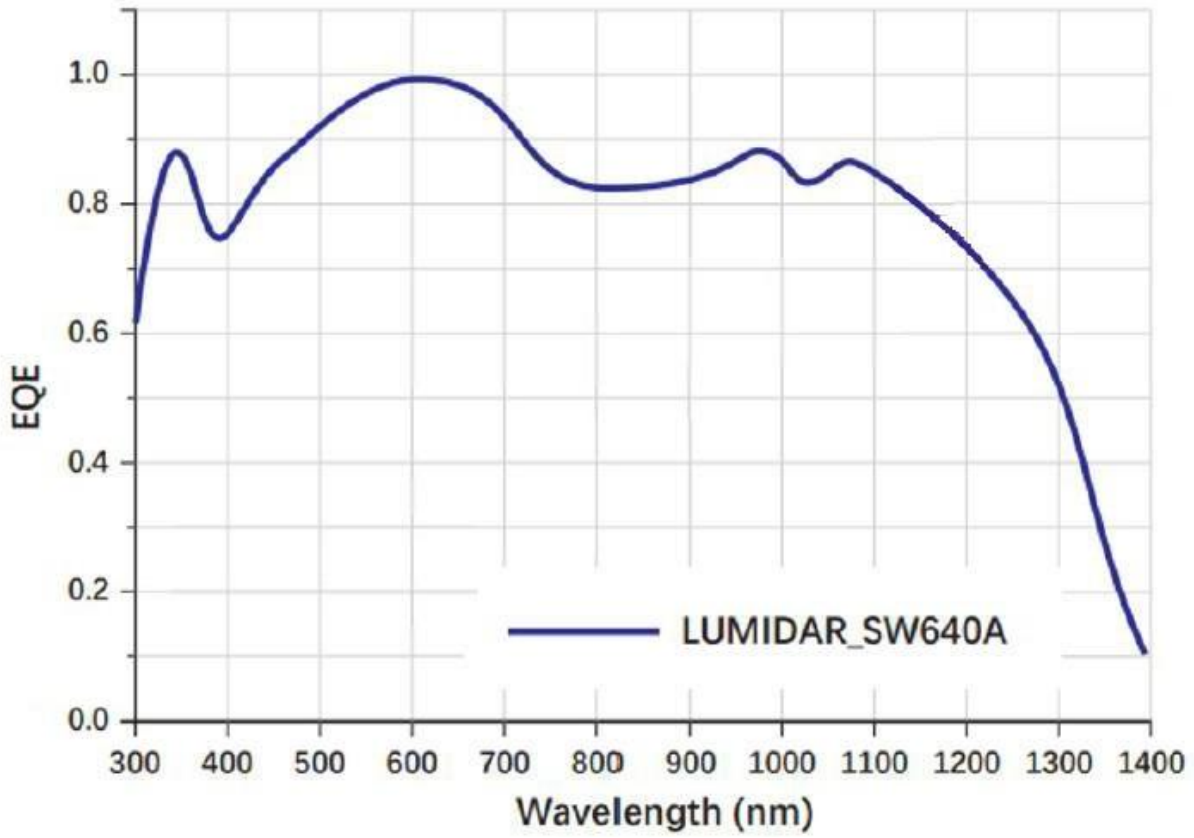

Figure 6-4 EHD336KMB-UMV QE Curve

7 Camera functions and features

7.1 10GigE / 5GigE / 2.5GigE / GigE camera specification

The GigE camera requires the host card's jumbo frame mode to be enabled to achieve the highest frame rate.

Ensure that the IP addresses of the GigE camera and PC network card are in the same network segment.

Support multiple cameras to work simultaneously and synchronize acquisition through external trigger interfaces.

7.2 CameraLink camera specification

The Cameralink camera transfers data using Geometry_1X4_1Y mode, the 12-bit camera transfers data in Medium mode, and the 14-bit camera transfers data in Full mode.

7.3 Camera operation mode

Camera operation mode support: Video Mode or Trigger Mode.

Camera Trigger Mode support: Soft Trigger Mode(Software) or External Trigger Mode(Isolated input, GPIO0, GPIO1, Counter or PWM).

7.4 Bit depth and ROI control

SWIR series has a built-in 12bit t / 14bit ADC, and the camera also support hardware ROI. The smaller the ROI size, the faster the frame rate.

7.5 Bandwidth and precise frame rate control

7.5.1 Bandwidth

SWIR series support bandwidth adjustment from 1% to 100%. As shown in Figure 7-1, the camera is with 100% bandwidth by default, and you can drag the slider to set the desired bandwidth.

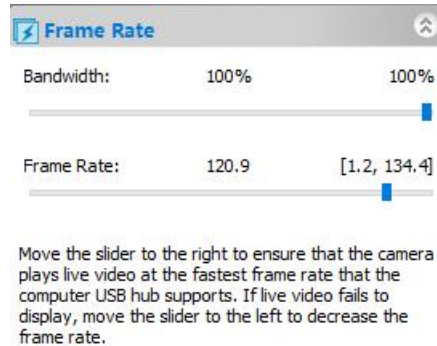

Figure 7-1 Bandwidth and precise frame rate settings

7.5.2 Precise frame rate control

SWIR series support precise frame rate control. The frame rate range will vary based on bandwidth, bit depth, resolution, ROI. As shown in Figure 7-1, the current frame rate can be set by dragging the Bandwidth or Frame Rate slider bar left or right.

7.6 DDR3 buffer

SWIR series has a built-in 512MByte (4Gb) DDR3 buffer, which can effectively improve the stability of USB3 / Cameralink / GigE data transmission and ensure that the camera does not lose frames when working.

7.7 Binning

SWIR series support additive or averaged 1×1 to 8×8 digital binning, and averaged 1×1 to 2×2 hardware binning. Hardware binning can achieve higher frame rates than software binning.

7.8 DC12V power supply and cooling system

When the DC12V power supply is plugged in, both the camera cooling system and the imaging system use a unified 12V power supply.

For USB camera, when the DC12V power supply is disconnected, the camera cooling system stops working, and the imaging system will automatically switch to the USB 5V power supply and the camera can work normally in passive cooling mode.

For GigE and CameraLink camera, when the DC12V power supply is disconnected, the camera cant work.

The cooling system of SWIR series has a built-in or external TEC cooling for the sensor. It uses an external heat dissipation structure and a fan to assist heat dissipation. The working temperature can be adjusted to a specific value, and the effective cooling temperature can be lower than the ambient temperature by 10 - 25 °C. The efficient cooling system guarantees extremely low dark current levels.

The TEC system is controlled by PID algorithm, so that the TEC can be accurately adjusted to the target temperature, and the temperature deviation is 0.1°C.

7.9 Camera performance analysis

The performance of the camera can be evaluated by [e-/ADU](#), [Readout Noise](#), [Full Well](#) and [Dynamic Range](#).

e-/ADU: The electron signal of the CCD/CMOS camera is converted into a digital signal through a series of circuits such as readout, amplification, and analog-to-digital converter. The converted digital signal unit is called **ADU**. The conversion factor is e-/ADU.

Readout Noise: Readout noise is the most important reference indicator for measuring camera performance. Low readout noise usually means better signal-to-noise ratio and better image quality. Readout noise occurs when electrons go through steps such as analog-to-digital conversion, amplification, and processing to create an image during readout.

Full Well: The maximum capacity of how many electrons could be held by each pixel of the camera. Under the same conditions of noise and A/D conversion, the larger the full-well charge capacity of the sensor, the wider the dynamic range.

Dynamic Range: Dynamic range is specified as the maximum achievable signal divided by the camera noise, where the signal strength is determined by the full-well capacity and noise is the sum of dark and readout noises.. Dynamic range represents the camera's ability to display the brightest and darkest parts of an image and how much there is variation between the two. There may be one part of an image that is completely black and another part that is completely saturated.

For SWIR series, when describing camera performance, [Gain Value](#) In xxx% mode, here use xxx as the x - axis ([Gain Value](#))

$$Rel\ Gain(dB) = 20 * \log_{10}[xxx(Gain\ Value)/100]$$

$$xxx(Gain\ Value) = 100 \times 10^{(Rel\ Gain(dB)/20)}$$

For details about the performance of the camera, see the parameters of each model or series.

7.10 Lens design guidelines

Information on lens selection is provided below.

The sensor imaging and the lenses are shown in Figure 7-2 and Figure 7-3.

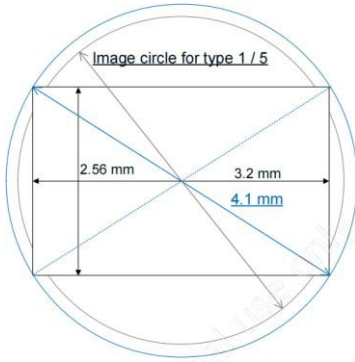

Figure 7-2 IMX991 relationship between image circle and pixel area

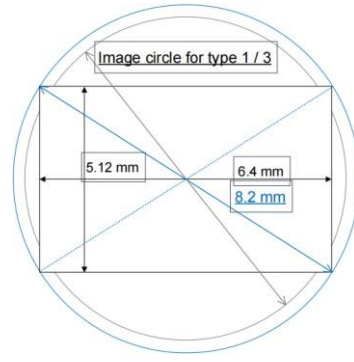

Figure 7-3 IMX990 relationship between image circle and pixel area

The following figure recommends the characteristics of CRA when the image height is from 0-100%.

7.11 CRA Characteristics

CRA (Chief Ray Angle) indicates the optimum chief-ray incidence angle at each image height, independent of the lens aperture size.

This sensor does not perform pupil correction. The chief ray is assumed to be a parallel ray (perpendicular to the sensor image plane).

The horizontal and vertical shading characteristics (reference values) for incident chief rays are shown below.

A register map for sensor information is also provided below.

7.11.1 Measurement Method

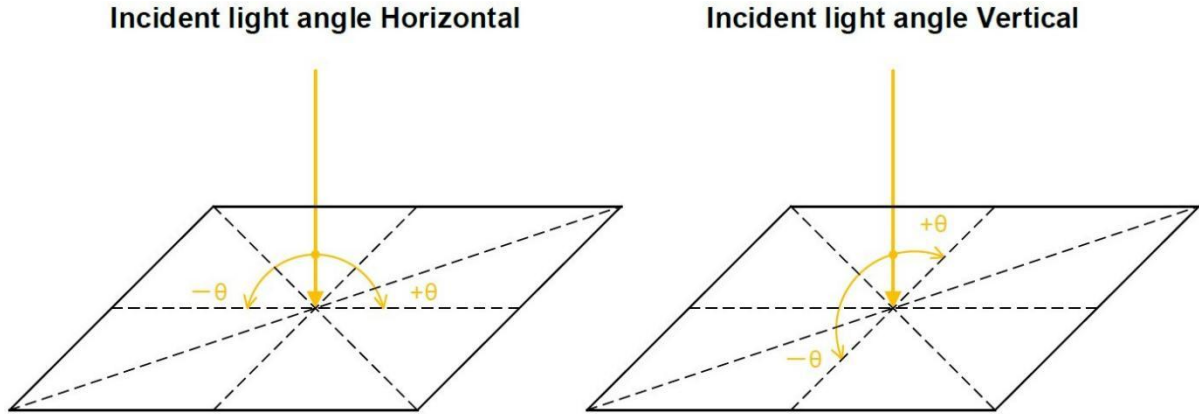

Figure 7-4 Left: Incident light angle (Horizontal); Right: Incident light angle (Vertical)

Input parallel light, and define A and B as follows:

- A: Output signal at an incidence angle of 0°.
- B: Output signal at each incidence angle (with COS correction).

A and B are measured as described above, and the relative value is calculated using the following formula:

$$\text{Shading [a.u.]} = B / A$$

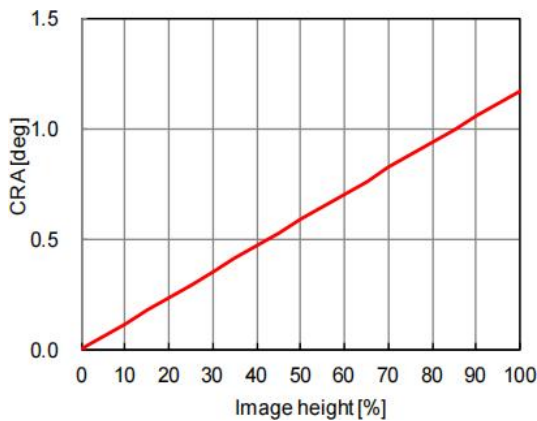

Figure 7-5 IMX991 CRA characteristics

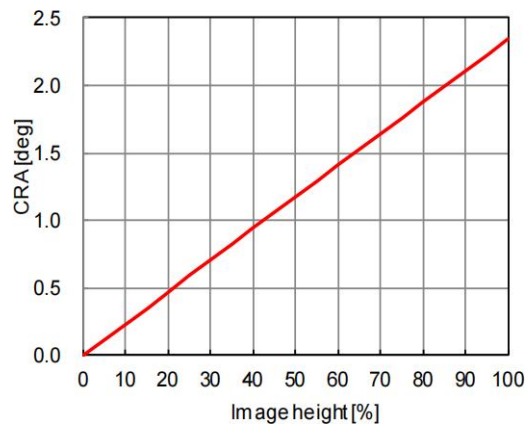

Figure 7-6 IMX990 CRA characteristics

Table 7-1 CRA(Chief Ray Angle) characteristics

IMX991		IMX990	
Image height		Image height	

(%)	(mm)	CRA (deg)	(%)	(mm)	CRA (deg)
0	0.00	0.00	0	0.00	0.00
5	0.10	0.06	5	0.20	0.12
10	0.20	0.12	10	0.41	0.23
15	0.31	0.18	15	0.61	0.35
20	0.41	0.23	20	0.82	0.47
25	0.51	0.29	25	1.02	0.59
30	0.61	0.35	30	1.23	0.70
35	0.72	0.41	35	1.43	0.82
40	0.82	0.47	40	1.64	0.94
45	0.92	0.53	45	1.84	1.06
50	1.02	0.59	50	2.05	1.17
55	1.13	0.65	55	2.25	1.29
60	1.23	0.70	60	2.46	1.41
65	1.33	0.76	65	2.66	1.53
70	1.43	0.82	70	2.87	1.64
75	1.54	0.88	75	3.07	1.76
80	1.64	0.94	80	3.28	1.88
85	1.74	1.00	85	3.48	1.99
90	1.84	1.06	90	3.69	2.11
95	1.95	1.12	95	3.89	2.23
100	2.05	1.17	100	4.10	2.35

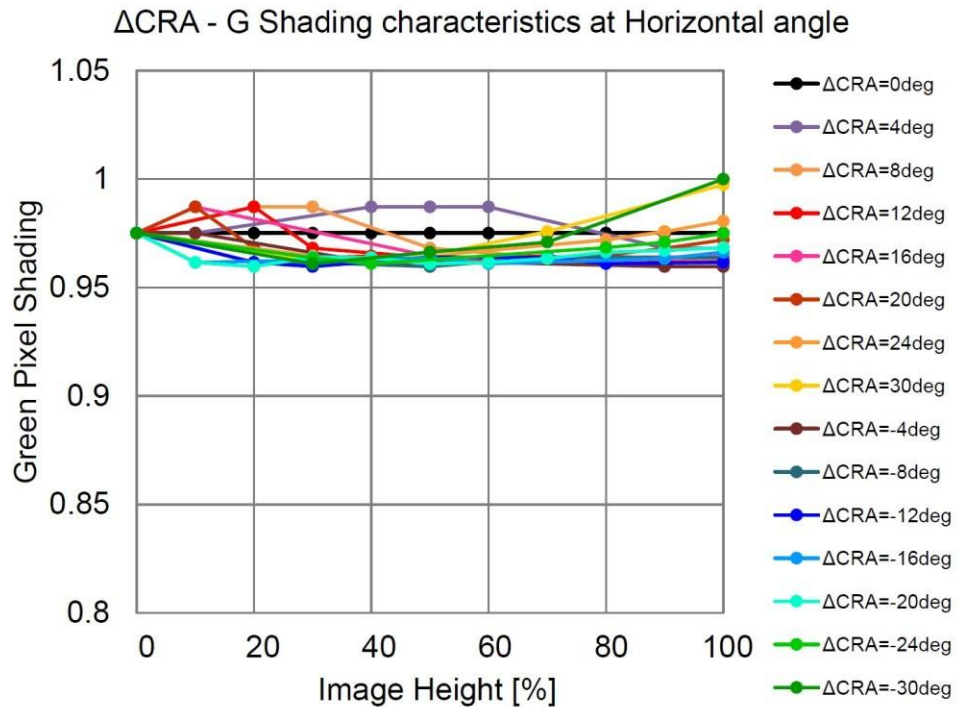

Figure 7-7 IMX992 CRA Characteristics

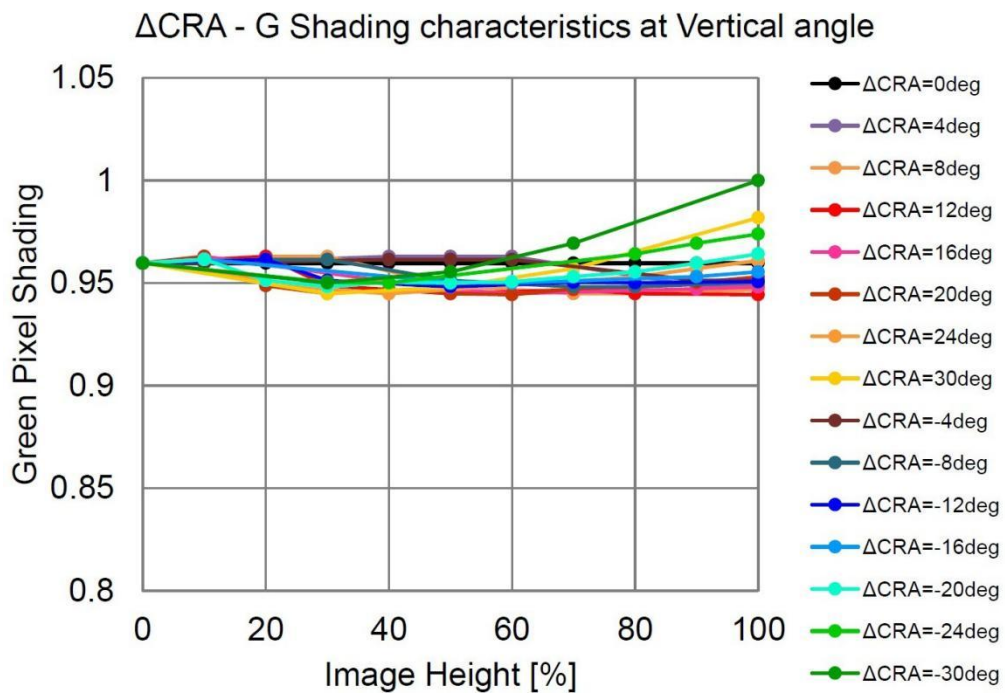

Figure 7-8 IMX993 CRA Characteristics

7.12 Filter

The SWIR series uses two filters: the long wave pass filter LPF390H and the long wave pass filter LP1000H.

LPF390H: D25X1MM cuts off 200-375HR- pass through 400-1800HT-T90-OD5

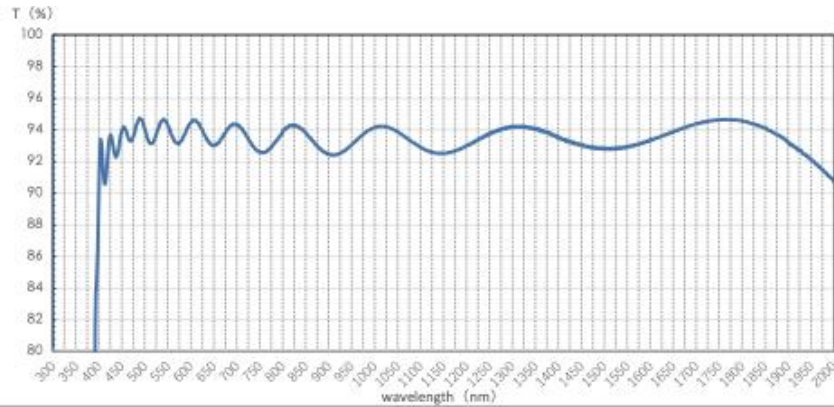

Figure 7-9 Long wave pass filter LPF390H transmittance curve

LP1000H: D25×2MM 200-980HR-1030-1800NM T90-OD5

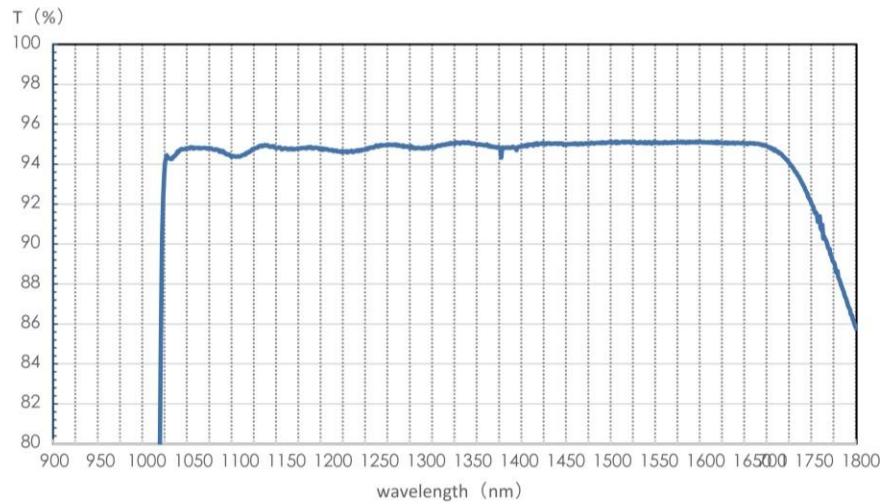
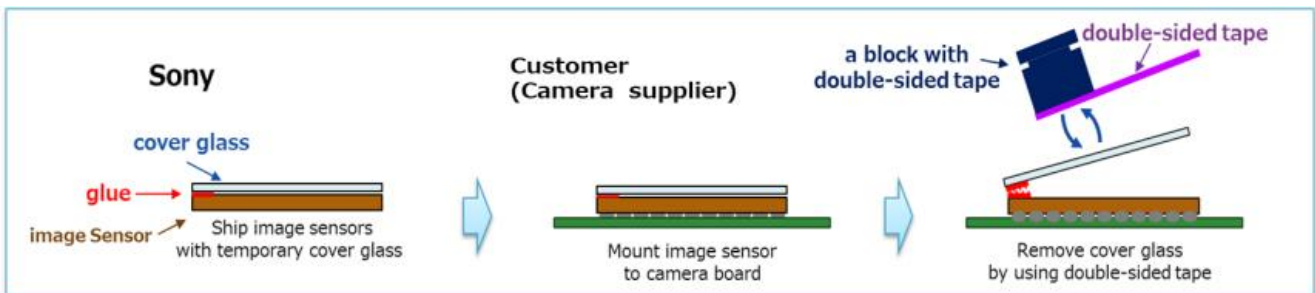

Figure 7-10 Long wave pass filter LP1000H transmittance curve

7.13 RG version description

EHD1300KMB-UMV and EHD330KMB-UMV are available in RG (de-glazing) versions, as shown in the figure below.



8 Camera dimensions and port

8.1 SWIR 400-1700 Camera dimensions and port

8.1.1 SWIR 400-1700 Camera dimensions



Figure 8-1 USB interface refrigerated camera dimensions

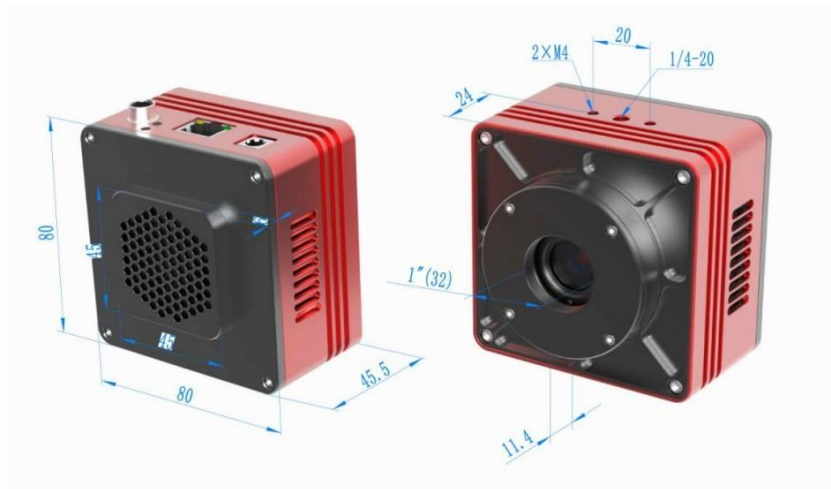

Figure 8-2 GigE interface refrigerated camera dimensions

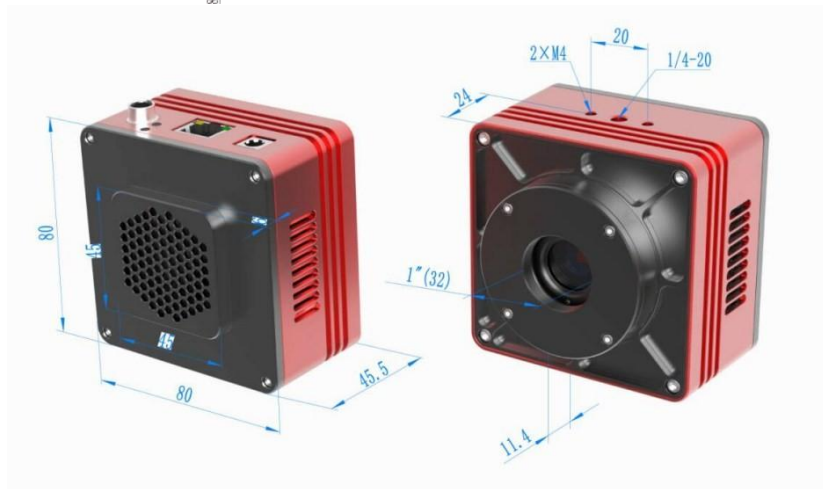
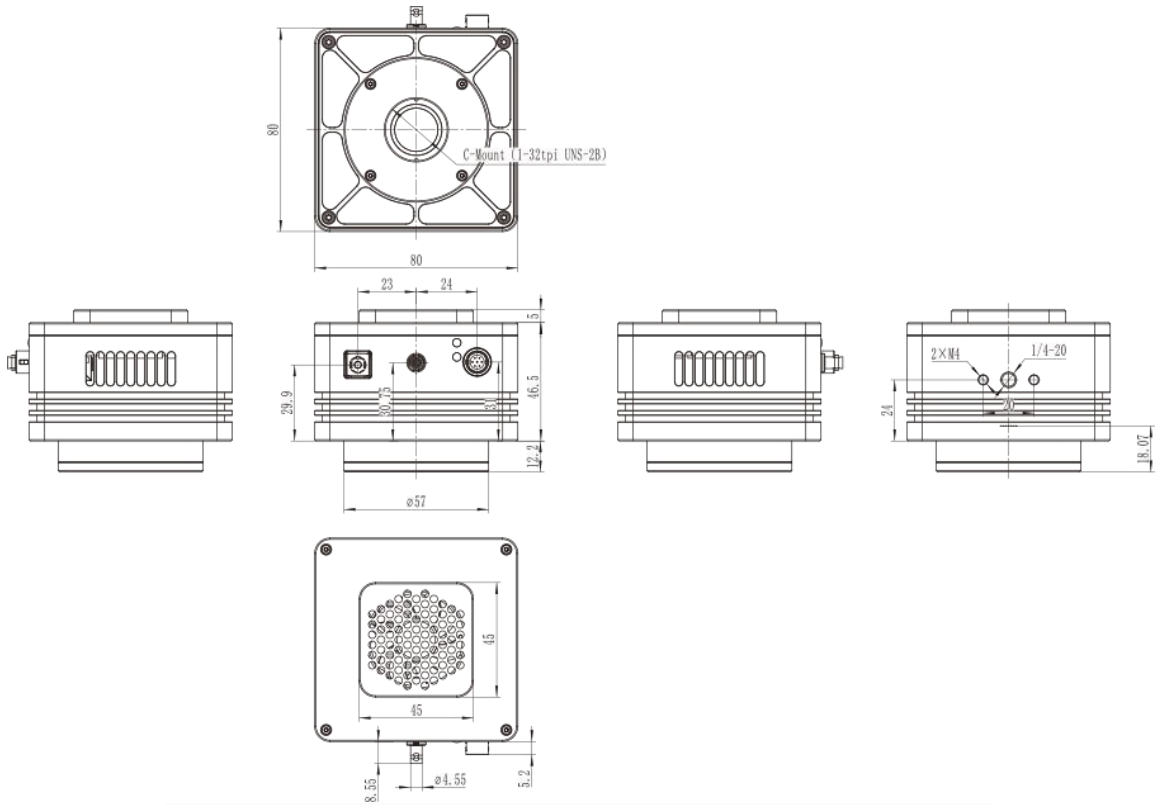

Figure 8-3 GigE interface refrigerated camera dimensions

Table 8-1 Refrigerated camera dimensions specification

Parameter	Specification
Size	80*80*45.5mm
Mount	C mount

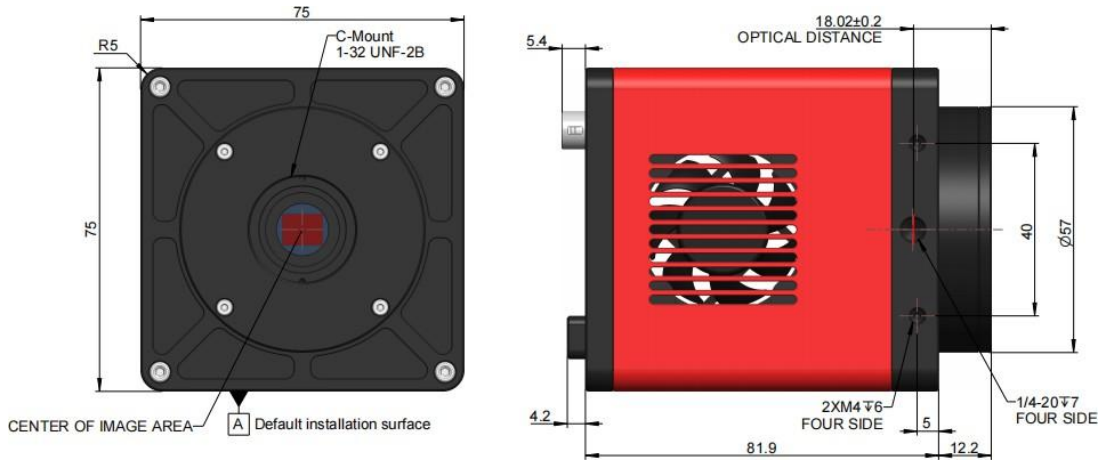

Figure 8-4 CL interface refrigerated camera dimensions

Table 8-2 Refrigerated camera dimensions specification

Parameter	Specification
Size	75*75*81.9mm
Mount	C mount

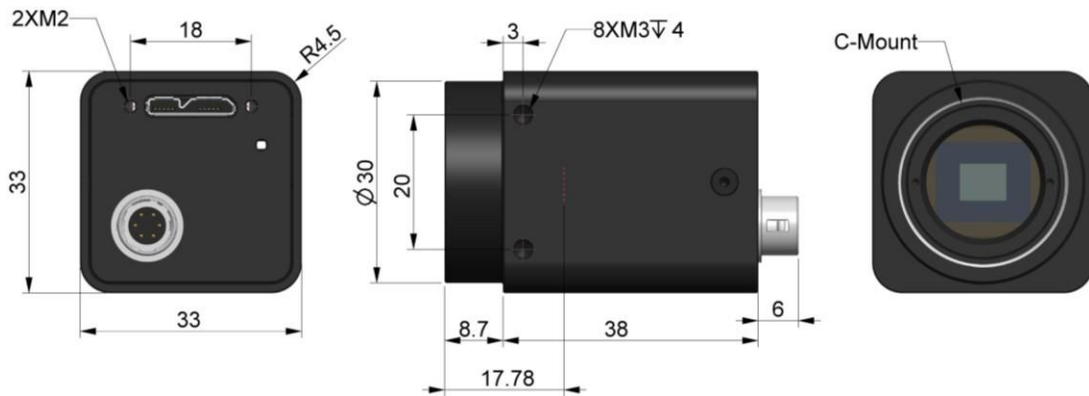

Figure 8-5 USB interface uncooled camera dimensions

Table 8-3 Uncooled camera dimensions specification

Parameter	Specification
Size	33*33*38mm
Mount	C mount

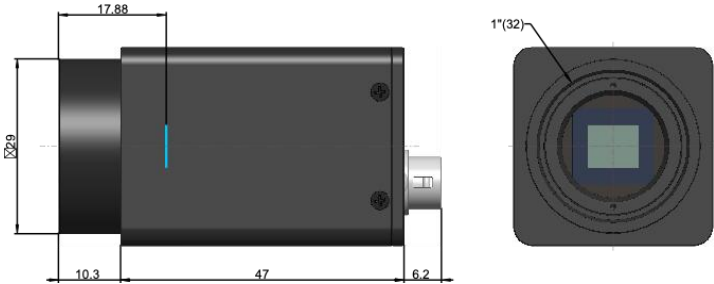

Figure 8-6 GIGe interface uncooled camera dimensions

Table 8-4 GIGe interface Uncooled camera dimensions specification

Parameter	Specification
Size	33*33*58mm
Mount	C mount

8.1.2 SWIR 400-1700 Camera port

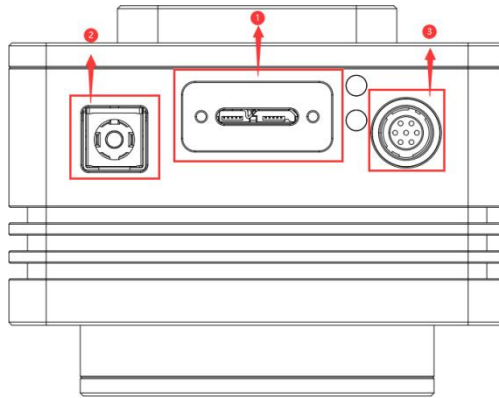

Figure 8-7 USB interface refrigerated camera

Table 8-5 USB interface refrigerated camera specification

Item	Specification
1	USB3.0 port
2	DC 12V power
3	External IO connection port

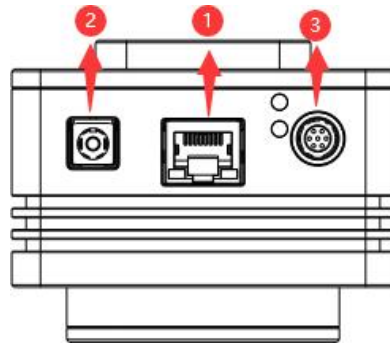

Figure 8-8 GigE interface refrigerated camera

Table 8-6 GigE interface refrigerated camera specification

Item	Specification
1	GigE port
2	DC 12V power
3	External IO connection port

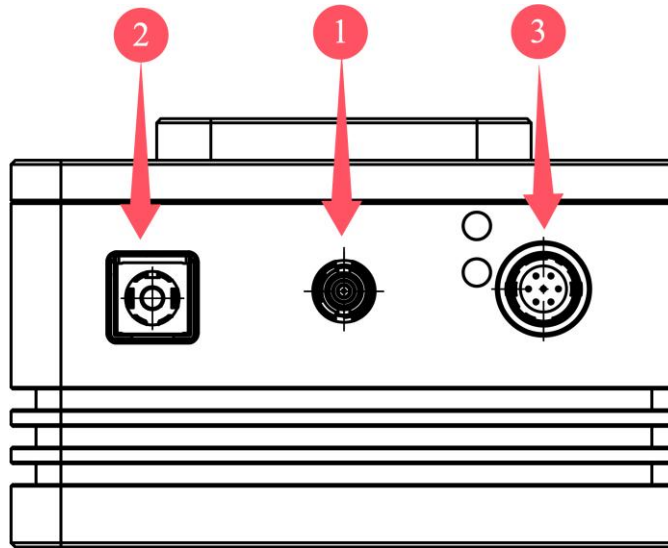

Figure 8-9 CXPinterface refrigerated camera

Table 8-7 CXPinterface refrigerated camera specification

Item	Specification
1	CoaXPress port
2	DC 12V power
3	External IO connection port

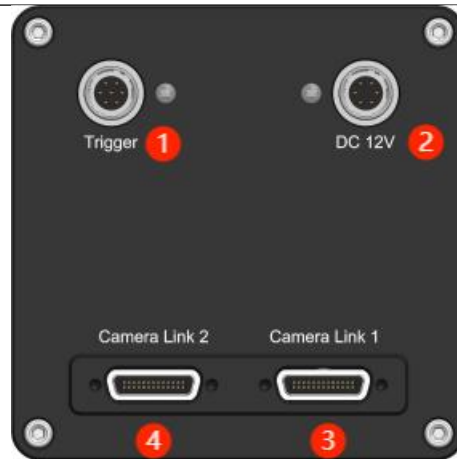

Figure 8-10 CL interface refrigerated camera

Table 8-8 CL interface refrigerated camera specification

Item	Specification
1	External IO connection port
2	DC 12V power
3	CameraLink1
4	CameraLink2

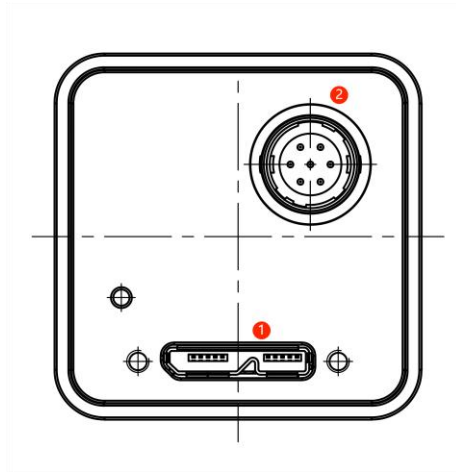

Figure 8-11 USB interface uncooled camera

Table 8-9 USB interface uncooled camera specification

Item	Specification
1	USB3.0 port
2	External IO connection port

8.2 SWIR 900-1700 Camera dimensions and port

8.2.1 EHD331 GigE/USB Camera dimensions

The camera can be rotated 90 degrees to change the forward direction. Customers can choose the appropriate installation direction according to their needs, please explain when placing an order.

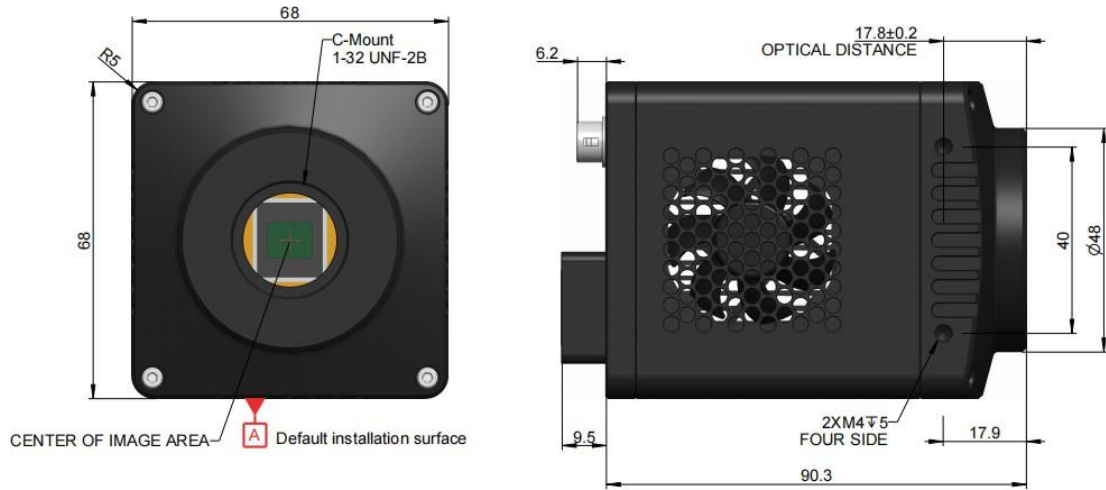

Figure 8-12 The Front and side view dimensions of the GigE interface camera

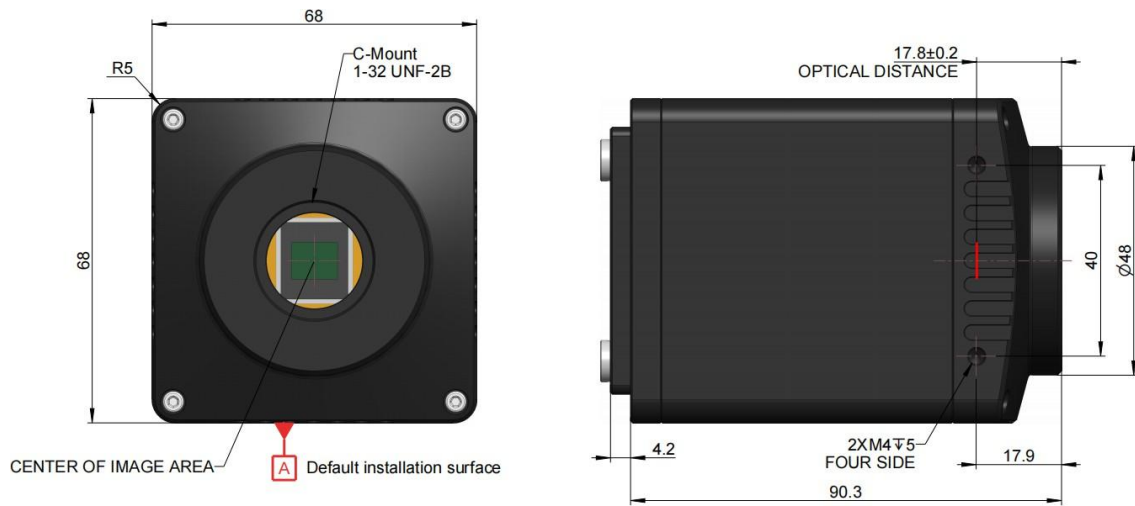

Figure 8-13 The Front and side view dimensions of the USB interface camera

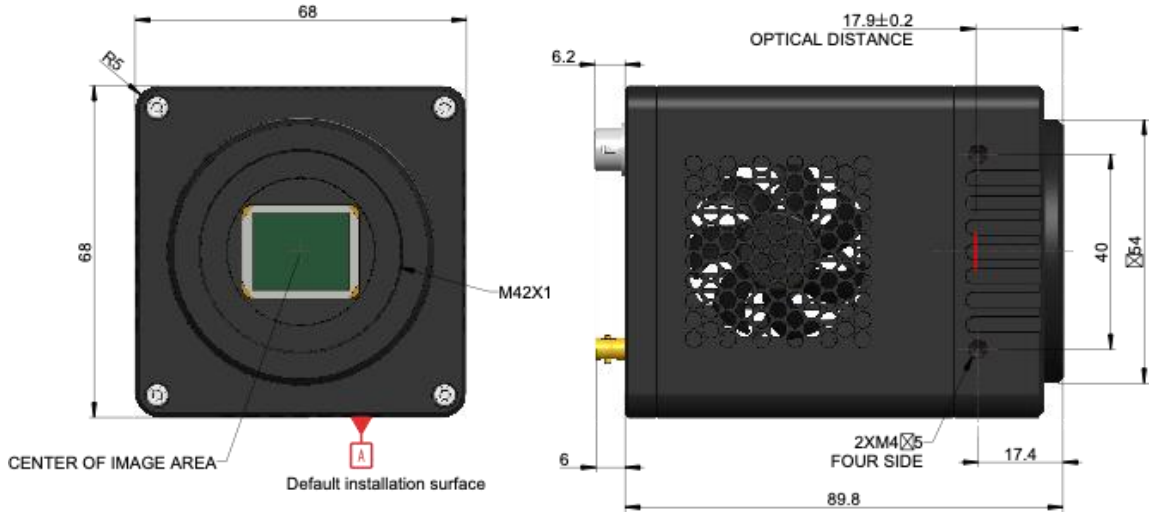

Figure 8-14 The Front and side view dimensions of the CXP interface camera

Table 8-10 Dimensions specification

Parameter	Specification
Size	68*68*90.3mm
Mount	C mount

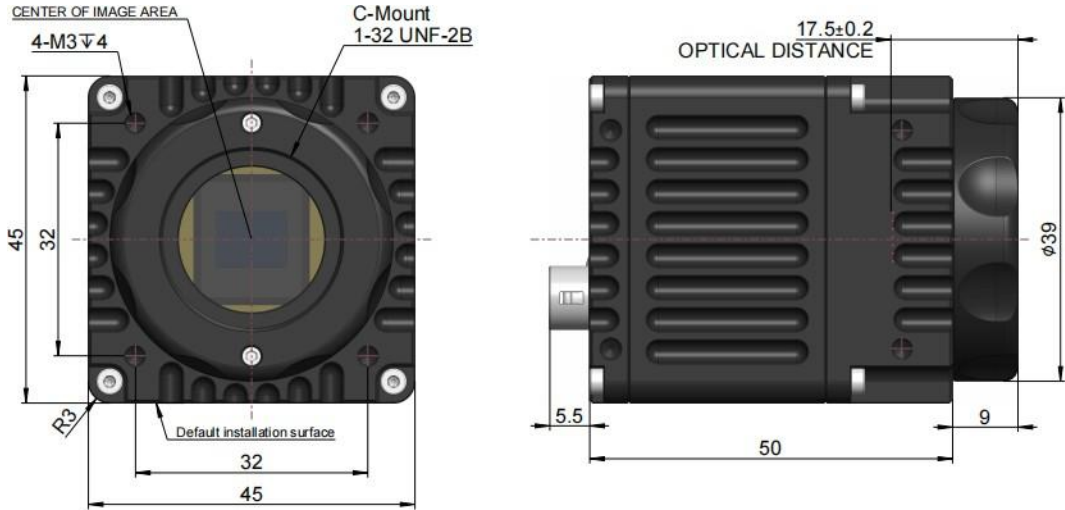

Figure 8-15 GigE/USB interface compact camera form factor

Table 8-11 Dimensions specification

Parameter	Specification
Size	45*45*50mm
Mount	C mount

8.2.2 EHD1302 Camera dimensions

The camera can be rotated 90 degrees to change the forward direction. Customers can choose the appropriate installation direction according to their needs, please explain when placing an order.

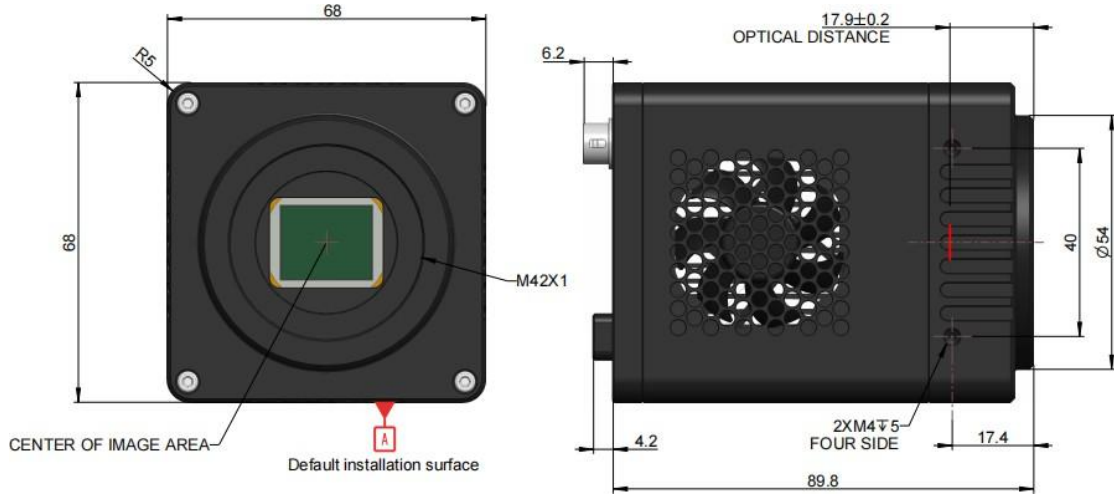

Figure 8-16 The Front and side view dimensions of the CL interface camera

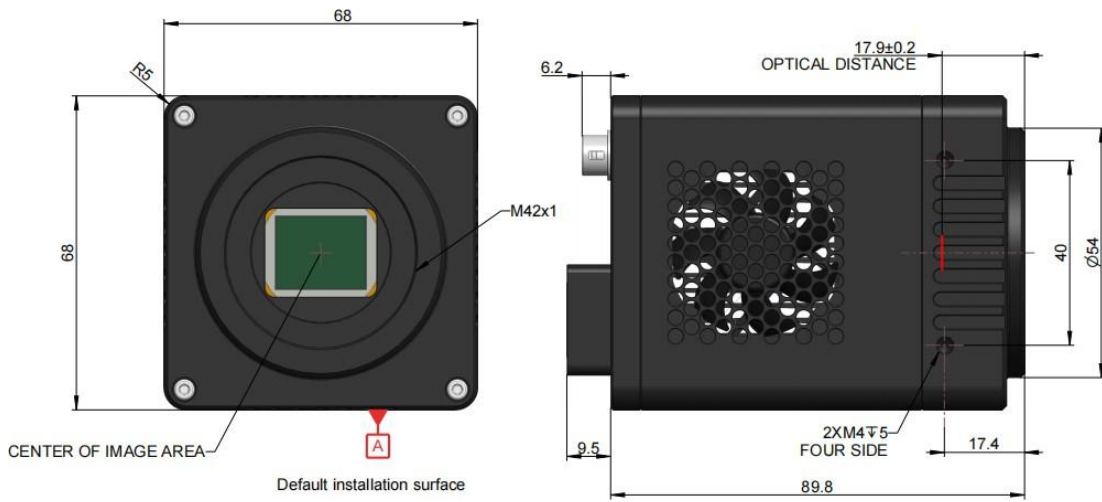

Figure 8-17 The Front and side view dimensions of the GigE interface camera

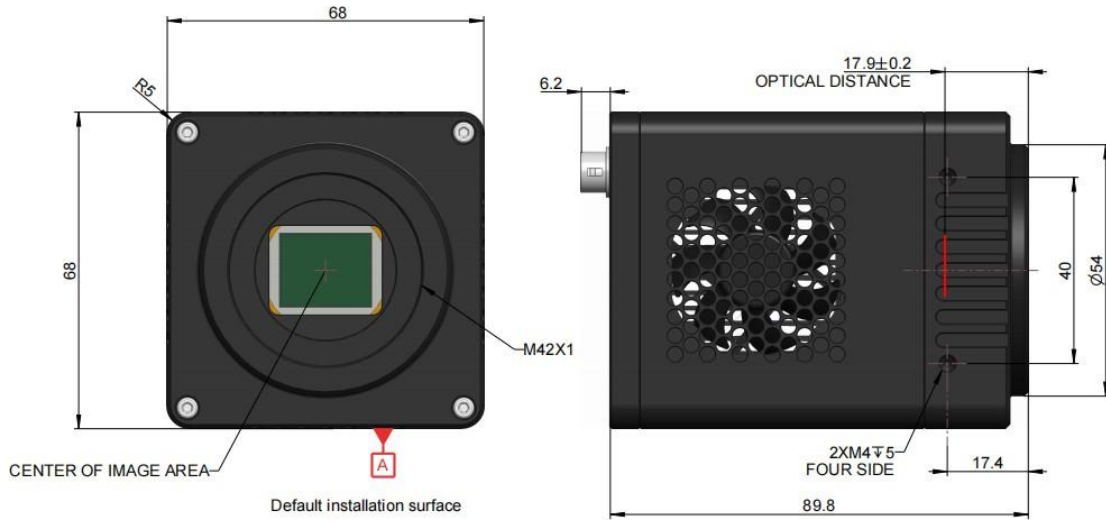

Figure 8-18 The Front and side view dimensions of the USB interface camera

Table 8-12 Dimensions specification

Parameter	Specification
Size	68*68*89.8mm
Mount	M42

8.2.3 SWIR 900-1700 Camera port

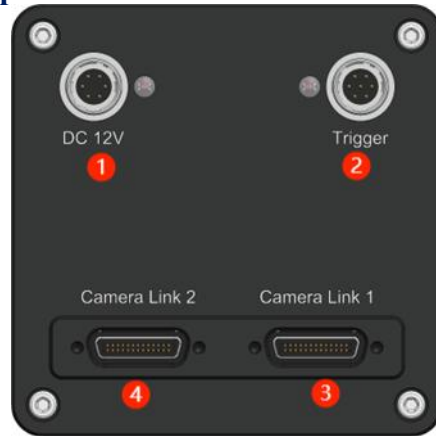

Figure 8-19 CL interface refrigerated camera

Table 8-13 CL interface refrigerated camera specification

Item	Specification
1	DC 12V power
2	External IO connection port
3	CameraLink1
4	CameraLink2

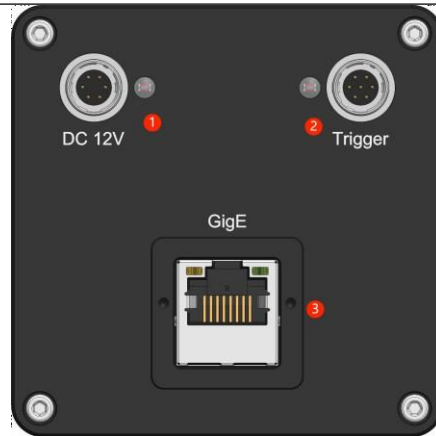

Figure 8-20 GigE interface refrigerated camera

Table 8-14 GigE interface refrigerated camera specification

Item	Specification
1	DC 12V power
2	External IO connection port
3	GigE port



Figure 8-21 USB interface refrigerated camera

Table 8-15 USB interface refrigerated camera specification

Item	Specification
1	DC 12V power
2	External IO connection port
3	USB port

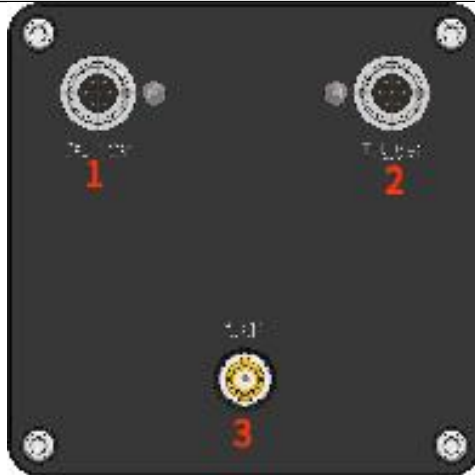

Figure 8-22 CXP interface refrigerated camera

Table 8-16 CXP interface interface refrigerated camera specification

Item	Specification
1	DC 12V power
2	External IO connection port
3	CoaXPress port



Figure 8-23 USB interface small size camera

Table 8-17 USB interface refrigerated camera specification

Item	Specification
1	USB port
2	External IO connection port

8.3 SWIR 400-2500 Camera dimensions and port

8.3.1 SWIR 400-2500 Camera dimensions

The camera can be rotated 90 degrees to change the forward direction. Customers can choose the appropriate installation direction according to their needs, please explain when placing an order.

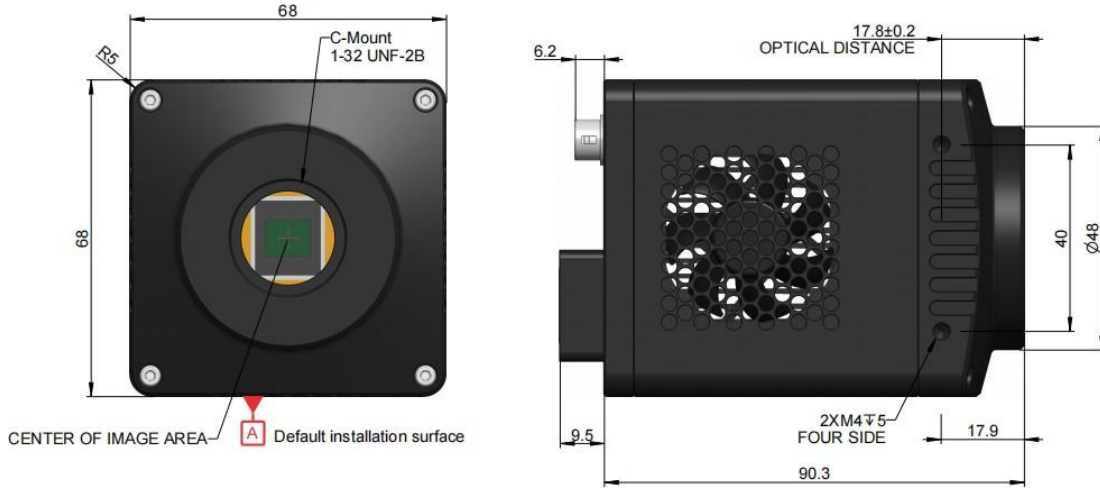

Figure 8-24 The Front and side view dimensions of the GigE interface camera

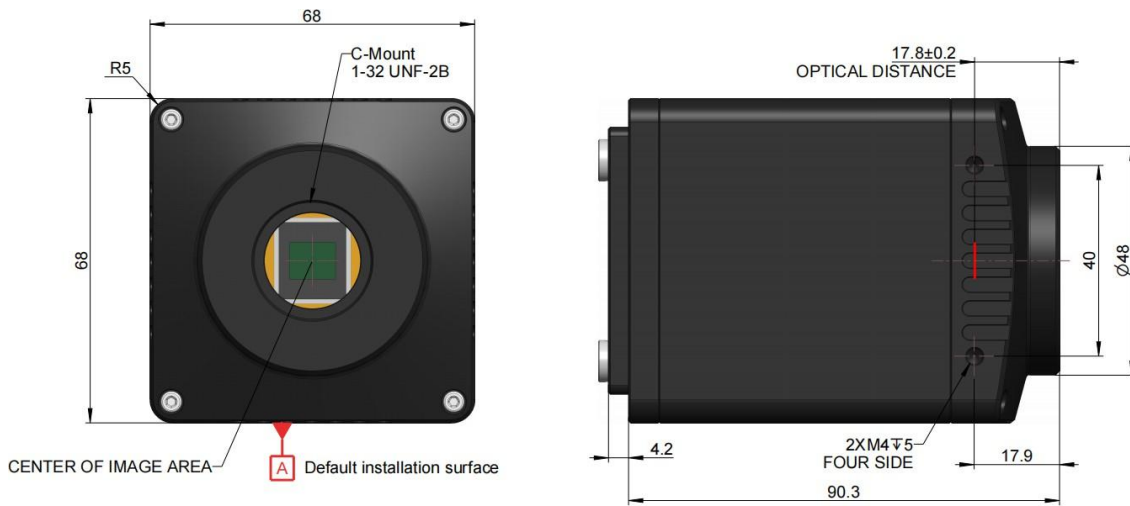

Figure 8-25 The Front and side view dimensions of the USB interface camera

Table 8-18 Dimensions specification

Parameter	Specification
Size	68*68*90.3mm
Mount	C mount

8.3.2 SWIR 400-2500 Camera port

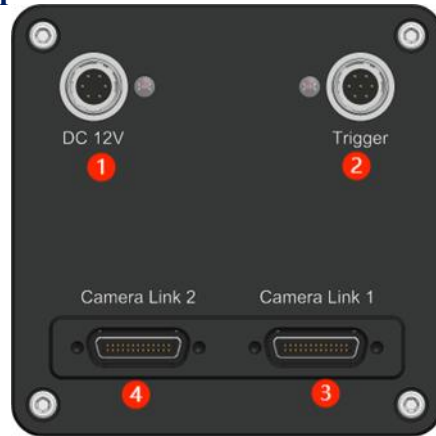

Figure 8-26 CL interface refrigerated camera

Table 8-19 CL interface refrigerated camera specification

Item	Specification
1	DC 12V power
2	External IO connection port
3	CameraLink1
4	CameraLink2



Figure 8-27 USB interface refrigerated camera

Table 8-20 USB interface refrigerated camera specification

Item	Specification
1	DC 12V power
2	External IO connection port
3	USB port

8.4 CQD 300-1700 Camera dimensions and port

8.4.1 CQD 300-1700 Camera dimensions

The camera can be rotated 90 degrees to change the forward direction. Customers can choose the appropriate installation direction according to their needs, please explain when placing an order.

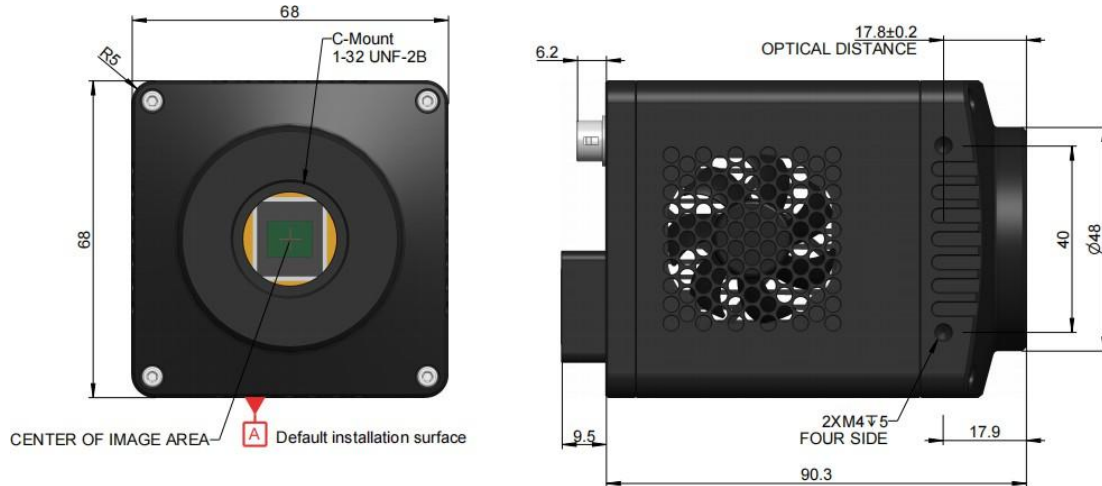

Figure 8-28 The Front and side view dimensions of the GigE interface camera

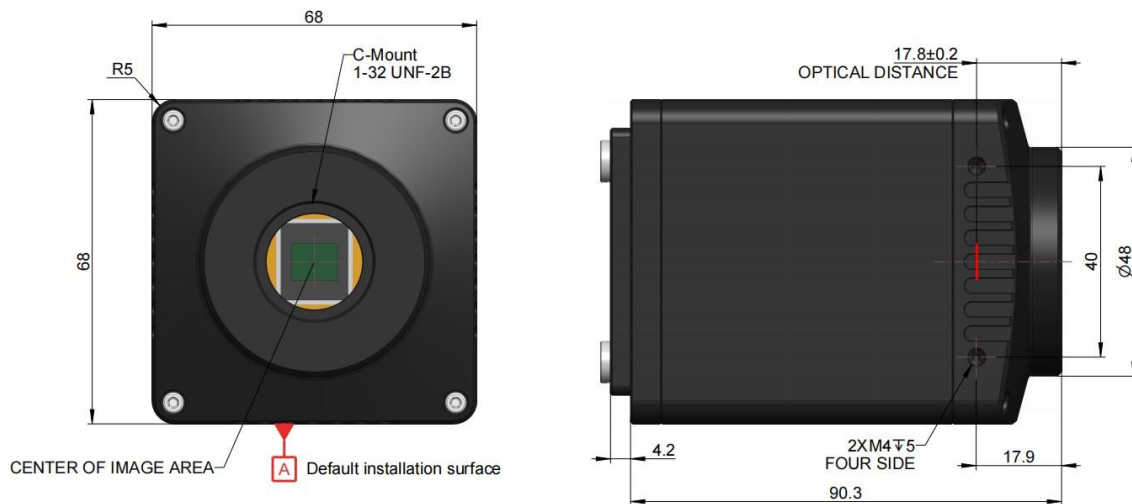

Figure 8-29 The Front and side view dimensions of the USB interface camera

Table 8-21 Dimensions specification

Parameter	Specification
Size	68*68*90.3mm
Mount	C mount

8.4.2 CQD 300-1700 Camera port



Figure 8-30 CL interface refrigerated camera

Table 8-22 CL interface refrigerated camera specification

Item	Specification
1	DC 12V power
2	External IO connection port
3	CameraLink1
4	CameraLink2



Figure 8-31 USB interface refrigerated camera

Table 8-23 USB interface refrigerated camera specification

Item	Specification
1	DC 12V power
2	External IO connection port
3	USB port

9 Packing list

9.1 SWIR 400-1700 camera packing list



Figure 9-1 USB refrigerated camera packing information

Table 9-1 USB refrigerated camera packing list

Standard Packaging List	
A	External box for B(not shown in this figure) Carton size: L:28.2cm W:25.2cm H:16.7cm
B	3-A safety equipment case: L:28cm W:23cm H:15.5cm (1pcs, 2.8Kg/ box)
C	SWIR 400-1700 series USB refrigerated camera
D	Power cord. National standard, American standard, European standard, British standard power cord (D1, D2, D3, D4) for choosing
E	Power adapter: Input: AC 100~240V 50Hz/60Hz, Output: DC 12V 3A
F	High-speed USB3.0 A male to B male gold-plated connector cable/1.5m
G	One external trigger control cable
H	OPTIONAL USB flash disk (with driver and application software in it)



Figure 9-2 GigE refrigerated camera packing information

Table 9-2 GigE refrigerated camera packing list

Standard Packaging List	
A	External box for B(not shown in this figure) Carton size: L:28.2cm W:25.2cm H:16.7cm
B	3-A safety equipment case: L:28cm W:23cm H:15.5cm (1pcs, 2.8Kg/ box)
C	SWIR 400-1700 series GigE refrigerated camera
D	Power cord. National standard, American standard, European standard, British standard power cord (D1, D2, D3, D4) for choosing
E	Power adapter: Input: AC 100~240V 50Hz/60Hz, Output: DC 12V 3A
F	One external trigger control cable
G	GigE cable: G1:3m G2:5m G3:10m(G4:50m not shown in this figure)
H	OPTIONAL USB flash disk (with driver and application software in it)



Figure 9-3 CoaXPress refrigerated camera packing information

Table 9-3 CoaXPress refrigerated camera packing list

Standard Packaging List	
A	External box for B(not shown in this figure) Carton size: L:28.2cm W:25.2cm H:16.7cm
B	3-A safety equipment case: L:28cm W:23cm H:15.5cm (1pcs, 2.8Kg/ box)
C	SWIR 400-1700 series CoaXPress refrigerated camera
D	Power cord. National standard, American standard, European standard, British standard power cord (D1, D2, D3, D4) for choosing
E	Power adapter: Input: AC 100~240V 50Hz/60Hz, Output: DC 12V 3A
F	One CoaXPress cable (Optional)
G	One external trigger control cable
H	OPTIONAL USB flash disk (with driver and application software in it)



Figure 9-4 CL refrigerated camera packing information

Table 9-4 CL refrigerated camera packing list

Standard Packaging List	
A	3-A safety equipment case: L:28cm W:23cm H:15.5cm (1pcs, 2.8Kg/ box)
B	SWIR 400-1700 series CL refrigerated camera
C	2 CameraLink cables (Optional)
D	12V/3A 6 PIN air plug power adapter
E	Power cord. National standard, American standard, European standard, British standard power cord (E1, E2, E3, E4) for choosing
F	One external trigger control cable



Figure 9-5 USB uncooled camera packing information

Table 9-5 USB uncooled camera packing list

Standard Packaging List	
A	External box for B(not shown in this figure) Carton size: L:28.2cm W:25.2cm H:16.7cm
B	3-A safety equipment case: L:28cm W:23cm H:15.5cm (1pcs, 2.8Kg/ box)
C	SWIR 400-1700 series USB uncooled camera
D	High-speed USB3.0 A male to B male gold-plated connector cable/1.5m
E	One external trigger control cable
F	OPTIONAL USB flash disk (with driver and application software in it)

9.2 SWIR 900-1700 camera packing list



Figure 9-6 GigE camera packing information

Table 9-6 GigE camera packing list

Standard Packaging List	
A	External box for B(not shown in this figure) Carton size: L:28.2cm W:25.2cm H:16.7cm
B	3-A safety equipment case: L:28cm W:23cm H:15.5cm (1pcs, 2.8Kg/ box)
C	SWIR 900-1700 series GigE camera
D	12V/3A 6 PIN air plug power adapter
E	Power adapter: Input: AC 100~240V 50Hz/60Hz, Output: DC 12V 3A
F	One external trigger control cable
G	GigE cable: G1:3m G2:5m G3:10m(G4:50m not shown in this figure)
H	OPTIONAL USB flash disk (with driver and application software in it)



Figure 9-7 USB camera packing information

Table 9-7 USB camera packing list

Standard Packaging List	
A	3-A safety equipment case: L:28cm W:23cm H:15.5cm (1pcs, 2.8Kg/ box)
B	SWIR 900-1700 series USB camera
C	High-speed USB3.0 A male to B male gold-plated connector cable/1.5m
D	12V/3A 6 PIN air plug power adapter
E	Power adapter: Input: AC 100~240V 50Hz/60Hz, Output: DC 12V 3A
F	One external trigger control cable

9.3 SWIR 400-2500 camera packing list



Figure 9-8 CameraLink camera packing information

Table 9-8 CameraLink camera packing list

Standard Packaging List	
A	3-A safety equipment case: L 28 cm × W 23 cm × H 15.5 cm (1 pcs, 2.8 kg/box)
B	SWIR 400-2500 nm CameraLink camera
C	CameraLink cable × 2 (Optional)
D	12 V / 3 A 6-pin aviation power adapter
E	Power cord (AC 100 – 240 V 50 Hz / 60 Hz → DC 12 V 3 A)
F	One external trigger control cable



Figure 9-9 USB camera packing information

Table 9-9 USB camera packing list

Standard Packaging List	
A	3-A safety equipment case: L:28cm W:23cm H:15.5cm (1pcs, 2.8Kg/ box)
B	SWIR 400-2500 series USB camera
C	High-speed USB3.0 A male to B male gold-plated connector cable/1.5m
D	12V/3A 6 PIN air plug power adapter
E	Power adapter: Input: AC 100~240V 50Hz/60Hz, Output: DC 12V 3A
F	One external trigger control cable

9.4 CQD 300-1700 camera packing list



Figure 9-10 CameraLink camera packing information

Table 9-10 CameraLink camera packing list

Standard Packaging List	
A	3-A safety equipment case: L 28 cm × W 23 cm × H 15.5 cm (1 pcs, 2.8 kg/box)
B	CQD 300-1700 nm CameraLink interface camera
C	CameraLink cable × 2 (Optional)
D	12 V / 3 A 6-pin aviation power adapter
E	Power cord (AC 100 – 240 V 50 Hz / 60 Hz → DC 12 V 3 A)
F	One external trigger control cable



Figure 9-11 USB camera packing information

Table 9-11 USB camera packing list

Standard Packaging List	
A	3-A safety equipment case: L:28cm W:23cm H:15.5cm (1pcs, 2.8Kg/ box)
B	CQD 300-1700 series USB camera
C	High-speed USB3.0 A male to B male gold-plated connector cable/1.5m
D	12V/3A 6 PIN air plug power adapter
E	Power adapter: Input: AC 100~240V 50Hz/60Hz, Output: DC 12V 3A
F	One external trigger control cable

10 External IO connector and electrical characteristics

10.1 SWIR 400-1700 camera Pin signal

Table 10-1 USB port / GigE port / CL port refrigerated camera pin signal definitions

	Color	Pin	Signal	Description of the signal
	White	1	GDN	Direct-coupled signal ground
	Red	2	12V	12VDC power input
	Blue	3	OPTO_GND	Opto-isolated signal ground
	Yellow	4	DIR_GPIO0	Direct-coupled General Purpose I/O (Software configurable input/output) (line2)
	Black	5	DIR_GPIO1	Direct-coupled General Purpose I/O (Software configurable input/output) (line3)
	Green	6	OPTO_IN	Opto-isolated input signal (line0)
	Pink	7	OPTO_OUT	Opto-isolated output signal (line1)

Table 10-2 USB uncooled camera(UMV) pin signal definition

	Color	Pin	Signal	Signal description
	red	1	DIR_GPIO	Direct-coupled General Purpose I/O (Software configurable input / output) (line2)
	white	2	OPTO_GND	Opto-isolated signal ground
	blue	3	OPTO_OUT	Opto-isolated output signal(line1)
	green	4	OPTO_IN	Opto-isolated input signal(line0)
	black	5	GND	Direct-coupled signal ground
	yellow	6	5V	5 VDC power input

10.2 SWIR 900-1700 camera Pin signal

Table 10-3 DC12V pin signal definitions

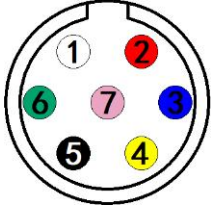
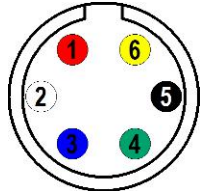
	Color	Pin	Signal	Description of the signal
	Red	1	12V	12V power supply positive
	Yellow	6	12V	
	Black	5	12V	
	White	2	GND	12V power supply negative
	Blue	3	GND	
	Green	4	GND	

Table 10-4 CL port Trigger pin signal definitions



	Color	Pin	Signal	Signaldescription
	Blue	3	OPTO_GND	Opto-isolated signal ground
	Green	6	OPTO_IN	Opto-isolated input signal (line0)
	Pink	7	OPTO_OUT	Opto-isolated output signal (line1)

Table 10-5GigE and USB port Trigger pin signal definitions

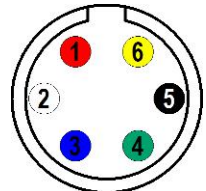
	Color	Pin	Signal	Signaldescription
	White	1	GND	Direct-coupled signal ground
	Red	2	12V	12VDC power input or output
	Blue	3	OPTO_GND	Opto-isolated signal ground
	Yellow	4	DIR_GPIO0	Direct-coupled General Purpose I/O (Software configurable input/output) (line2)
	Black	5	DIR_GPIO1	Direct-coupled General Purpose I/O (Software configurable input/output) (line3)
	Green	6	OPTO_IN	Opto-isolated input signal (line0)

	Pink	7	OPTO_OUT	Opto-isolated output signal (line1)
---	------	---	----------	-------------------------------------

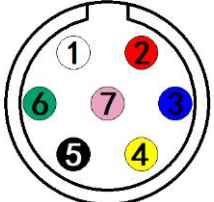
10.3 SWIR 400-2500 camera Pin signal

Table 10-6 DC12V pin signal definitions

	Color	Pin	Signal	Description of the signal
	Red	1	12V	12V power supply positive
	Yellow	6	12V	
	Black	5	12V	
	White	2	GND	12V power supply negative
	Blue	3	GND	
Green	4	GND		

Table 10-7 CL port Trigger pin signal definitions

	Color	Pin	Signal	Signaldescription
	Blue	3	OPTO_GND	Opto-isolated signal ground
	Green	6	OPTO_IN	Opto-isolated input signal (line0)
	Pink	7	OPTO_OUT	Opto-isolated output signal (line1)

Table 10-8GigE and USB port Trigger pin signal definitions

	Color	Pin	Signal	Signaldescription
	White	1	GND	Direct-coupled signal ground
	Red	2	12V	12VDC power input or output
	Blue	3	OPTO_GND	Opto-isolated signal ground
	Yellow	4	DIR_GPIO0	Direct-coupled General Purpose I/O (Software configurable input/output) (line2)
	Black	5	DIR_GPIO1	Direct-coupled General Purpose I/O (Software configurable input/output) (line3)
	Green	6	OPTO_IN	Opto-isolated input signal (line0)
	Pink	7	OPTO_OUT	Opto-isolated output signal (line1)

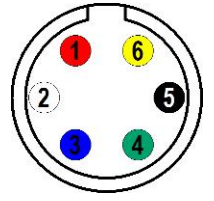
10.4 I/O electrical characteristics

10.4.1 Opto-isolated input circuit (line0)

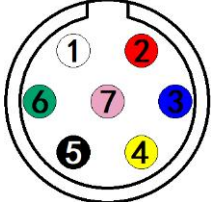
In the I/O control of the camera, the opto-isolated input circuit is shown in Figure 10-1.

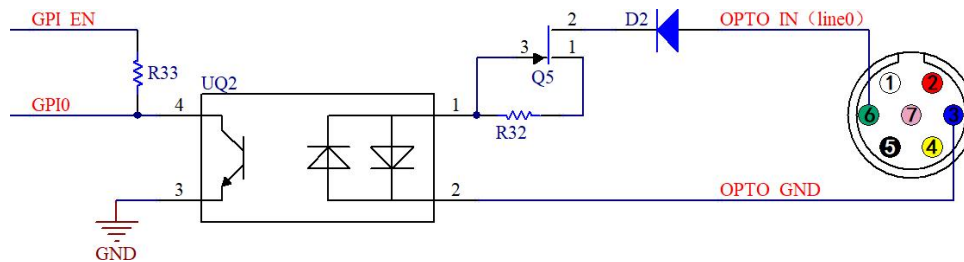

Figure 10-1 Opto-isolated input circuit

Logic 0 input level: 0~2.2VDC (OPTO_IN pin)

Logic 1 input level: 3.3~24VDC (OPTO_IN pin)

Maximum input current: 30mA

When the input level is between 2.2V and 3.2V, the circuit operation state is uncertain, please do not let SWIR camera work within this voltage range.

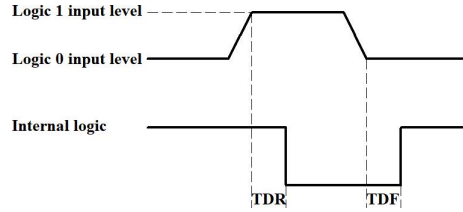

Figure 10-2 Input logic levels

Input rise delay (TDR): 6us

Input fall delay (TDF): 6us

10.4.2 Opto-isolated output circuit (line1)

In the camera I/O control, the opto-isolated output circuit is shown in Figure 10-3.

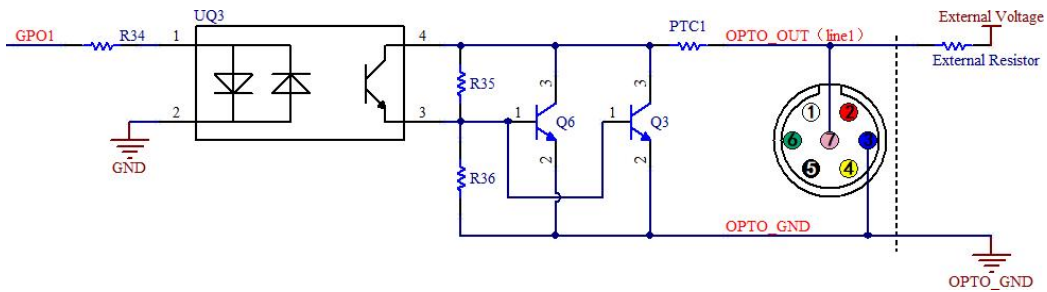

Figure 10-3 Optocoupler output circuit

The opto-isolated output maximum current is 30mA.

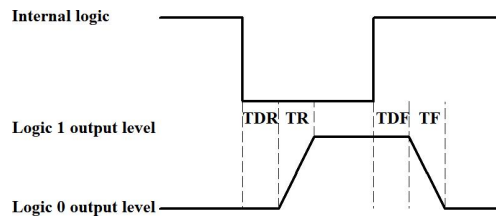

Figure 10-4 Output logic levels

The electrical characteristics of the opto-isolated output (external voltage 5V, external resistor 1K) are shown in Table 10-9.

Table 10-9 Opto-isolated output signal's electrical characteristics

Parameter name	Parameter notation	Parameter value
Output logic low	VL	742mV
Output logic high	VH	4.134V
Output rise time	TR	4us
Output fall time	TF	1.8us

Output rise delay	TDR	12us
Output fall delay	TDF	2us

The output of the corresponding output current and VL when using different voltages and resistors in external circuit are shown in Table 10-10.

Table 10-10 Opto-isolated output logic's low levels parameters

External voltage	External resistor	VL	Outputcurrent
3.3V	1KΩ	510mV	2.82mA
5V	1KΩ	742mV	4.31mA
12V	2.4KΩ	795mV	4.68mA
24V	4.7KΩ	850mV	4.97mA

10.4.3 Input and output I/O circuit (line2/line3)

The non-isolated configurable input and output I/O circuits are shown in Figure 10-5 and Figure 10-6.

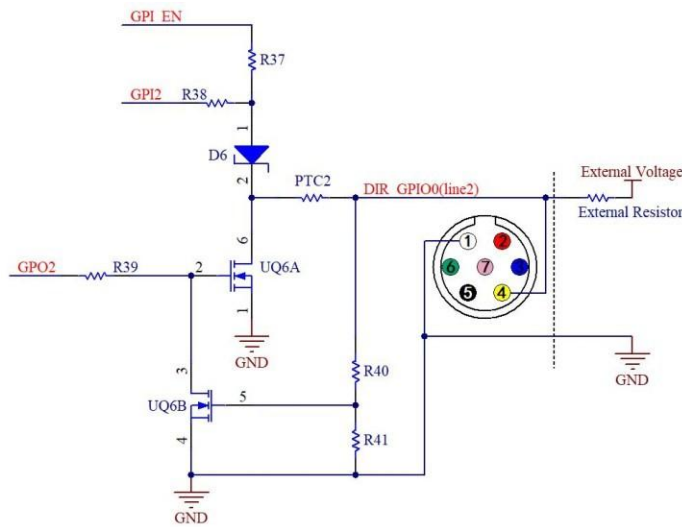

Figure 10-5 Non-isolated configurable input and output I/O circuit (line2)

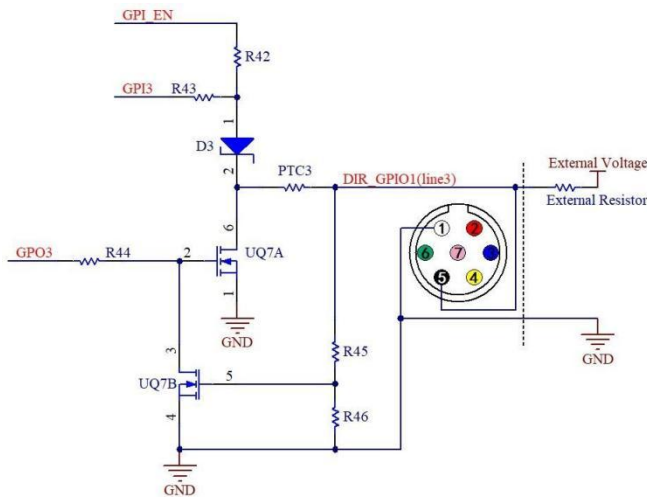

Figure 10-6 Non-isolated configurable input and output I/O circuit (line3)

1. Line2/line3 is set as input pin

Logic 0 input level: 0~0.6VDC (DIR_GPIO0/DIR_GPIO1 pins)

Logic 1 input level: 2.0~24VDC (DIR_GPIO0/DIR_GPIO1 pins)

Maximum input current: 25mA

When the input level is between 0.6V and 2.0V, the circuit action state is uncertain, please avoid the input voltage range working in this range.

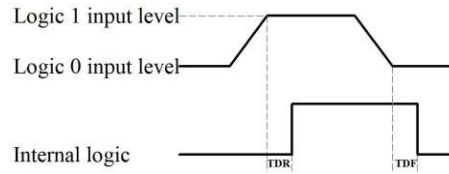

Figure 10-7 Input logic levels

To prevent damage to the GPIO pins, please connect the pin GND first, and then input voltage to the Line2 pin.

Input rise delay (TDR): 0.02us

Input fall delay (TDF): 0.02us

2.Line2/line3 are set as output pins

The maximum current allowed through this pin is 25mA.

When the ambient temperature is 25 degrees Celsius, the relationship between the external voltage, resistance and low-level voltage output is shown in Table 10-11.

Table 10-11 Non-isolated output Logic's low level parameters

External voltage	External resistor	VL(GPIO)
3.3V	1KΩ	0.11V
5V	1KΩ	0.167V
12V	2.4KΩ	0.184V
24V	4.7KΩ	0.385V

The external pull-up voltage is 5V, the pull-up resistor is 1KΩ, and the GPIO is configured to output the logic level and electrical characteristics as shown in Figure 10-8.

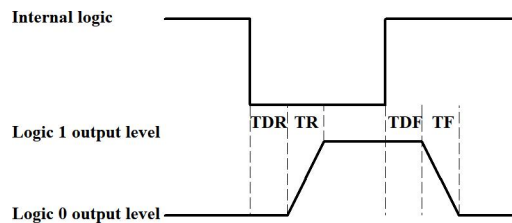

Figure 10-8 Output logic levels

Table 10-12 Non-isolated output electrical characteristics

Parameter name	Parameter notation	Parameter value
Output rise time	TR	0.08us
output fall time	TF	0.02us
Output rise delay	TDR	0.1us
Output fall delay	TDF	0.04us

11 EHDview Application

11.1 Application installation

In terms of software, customers are welcome to visit our website:<https://www.touptekphotonics.com/> to download the latest EHDview. SWIR series can also be used with ASCOM, DirectShow interface. If the third-party software is compatible with these interfaces, customers can also download software drivers from our website and install them into the third-party software.

11.2 Introduction to EHDview is a professional software that integrates camera control, image acquisition and processing, image browsing and analysis functions. EHDview has the following characteristics:

- x86: XP SP3 and above ; CPU support SSE2 and above
- x64: Win7 and above
- Support video mode and Trigger Mode (Raw format or RGB format)
- Automatic capture and quick recording capabilities
- Support multiple languages
- Hardware ROI and digital binning capabilities
- Rich image processing functions, such as image stitching, real-time overlay, flat field correction, dark field correction, etc.
- Support all EHD imaging GmbH cameras

11.2.1 User interface design

- The menus and toolbars are properly set to ensure quick operation
- Professionally integrated with 5 sidebars - Camera, Folders, Undo/Redo, Layers, Measure
- Comfortable operation method (double-click or right-click context menu)
- Detailed help manual

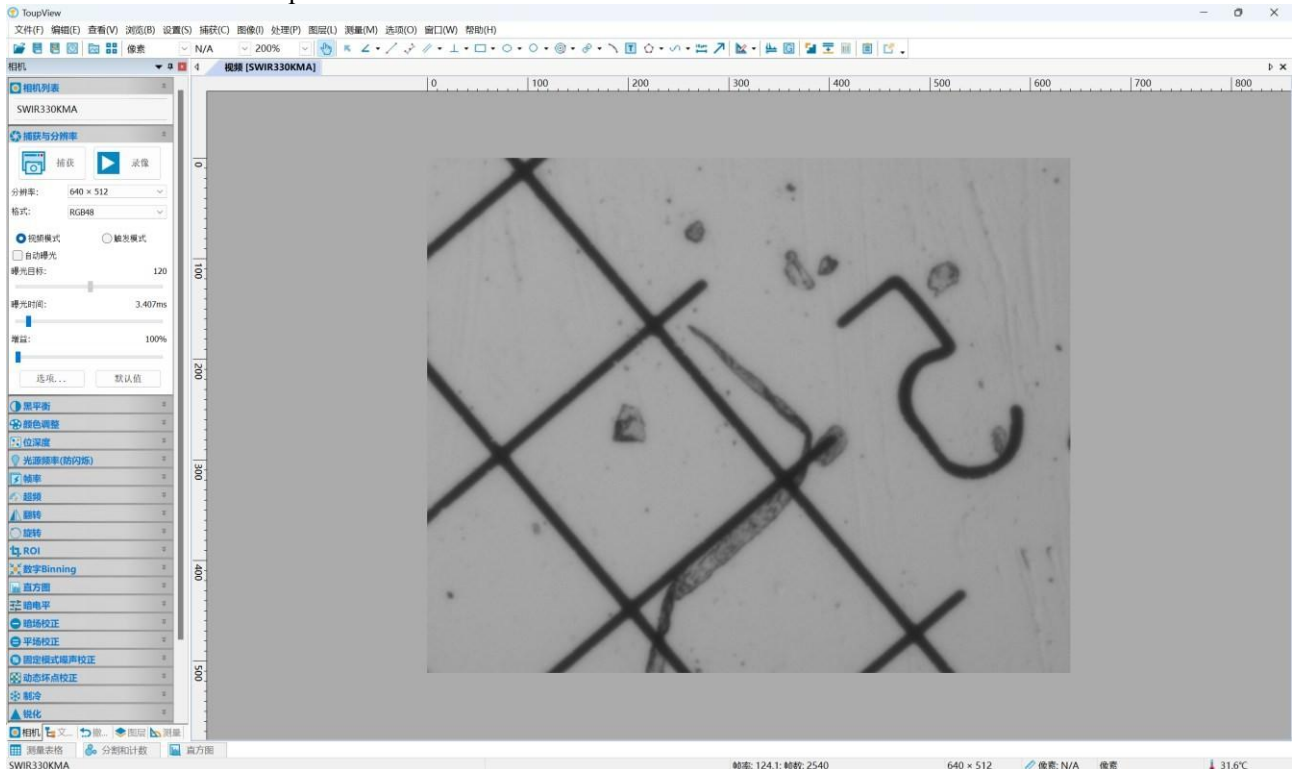

Figure 11-1 EHDview video window

11.2.2 Professional Camera Control Sidebar

Capture & Resolution	Set up live and still capture, snap images, or record video
Exposure & Gain	Auto exposure (preset exposure target value), manual exposure (exposure time can be manually entered and set by slider); gain up to 5 times
White Balance	Advanced one-click smart white balance settings, and you can adjust white balance by manually setting color temperature and color
Color Adjustment	Color, saturation, brightness, contrast, gamma initial high-speed adjustment function
Frame Rate Control	For different computer and USB performance, the camera can be super compatible by adjusting the frame rate
Flip	Select "Horizontal" or "Vertical" to adjust the sample orientation to ensure the same orientation as the visual system
Sampling	Neighborhood averaging can improve the signal-to-noise ratio of the video stream; while the sampling extraction mode can ensure the sharpness of the video stream. Support histogram expansion of video stream, image negative and positive switching, grayscale calibration, and sharpness factor calculation to facilitate video focusing
Bit Depth	8, 12-bit switching, 8-bit is the basic Windows image format. 12-bit has higher image quality but reduces frame rate
Roi	ROI, Region of interest. This function can set the ROI value of the video window. After the ROI group is expanded, a rectangular box will appear in the middle of the video window, and the ROI can be changed. The mouse can adjust the size of the ROI. If there is no problem with the ROI, click "Apply" to set the video to the size of the ROI, and the default value will be restored to the original size.
Dark Field Correction	To enable darkfield correction, you should first capture a field image, then click Enable. Check Enable to enable darkfield correction. Uncheck it to disable darkfield correction
Cooling	Set TEC Target Temperature, fan on/off
Parameter Save	Load, save, overwrite, load, export custom camera panel controls (including calibration information, exposure parameters and color settings information, etc.)

11.2.3 Professional and practical image processing functions

Video Function	Various video professional processing functions: video broadcasting, timing capture, video recording, video watermarking, watermark mobile alignment, watermark rotation alignment, video grid overlay, video measurement, video scaling, gray scale calibration, video high dynamic (HDR), video depth of field extension, video image stitching, video scale, date, etc.
Image Processing and Enhancement	Image contrast control and adjustment, image denoising, various image filtering algorithms, image mathematical morphology algorithms, image rotation, image scaling and image printing, etc.
Image Overlay	The EHDview image overlay denoising function introduces advanced image matching technology. Users only need to record a short video of the image to be superimposed, and they can superimpose and output high fidelity in the case of displacement, rotation and magnification change between multiple frames of the video. images, easy to use

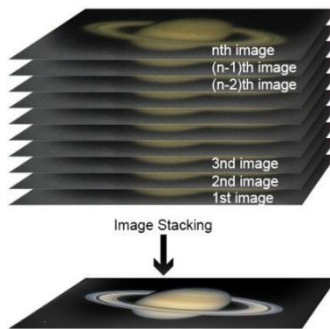

Figure 11-2 Image overlay denoising

11.2.4 Super compatibility

Camera Video Interface	Provide Twain, DirectShow, Labview, SDK installation package (native C++, C#)
Supported Operating Systems	Compatible with Microsoft® Windows® XP / Vista / 7 / 8 / 10 / 11(32 & 64 bit), Mac OSX, Linux
Language Support	Language support can be added manually, currently support English, Simplified Chinese, Traditional Chinese, German, Japanese, Russian, French, Italian, Polish, Turkish

11.2.5 Basic hardware requirements

PC Basic Configuration Requirements	CPU: Intel Core 2 2.8GHz or higher
	RAM: 2GB or more

	USB Port: USB3.0 / USB 2.0
	Monitor: 17" or higher
	CD-ROM

11.3 Trigger Mode and its Configuration

11.3.1 Video mode and Trigger mode

The trigger function can be found on the **Capture & Resolution** group on the **Camera Sidebar** in EHDview. When the camera is opened, it is in **Video Mode** as shown in Figure 11-3 on the left. In **Video Mode**, **Auto Exposure**, **Exposure Target**, **Exposure Time** and **Gain** can be set. One can switch to **Trigger Mode** by checking the **Trigger Mode** check box.

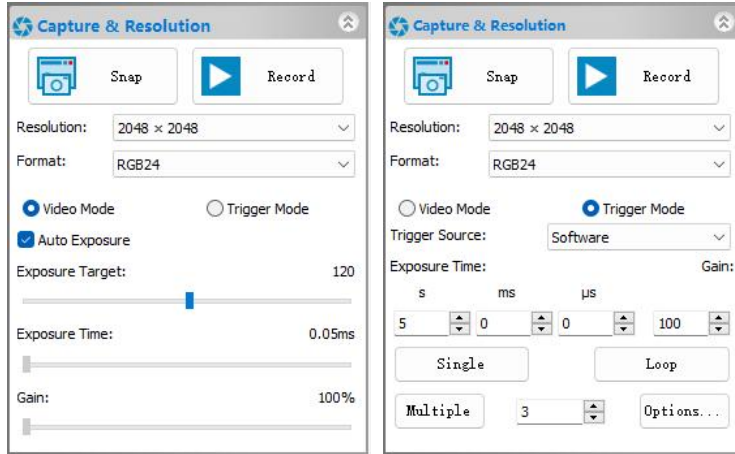

Figure 11-3 Video Mode and Trigger Mode on the Capture & Resolution group in EHDview

After the **Trigger Mode** is checked, the **Capture & Resolution** group will switch to **Trigger Mode** as shown in Figure 11-3 on the right. Where, the **Trigger Source**, **Exposure Time**, **Gain**, **Single**, **Loop**, **Multiple**, **Frame Box**, and **Options** can be set.

11.3.2 Trigger Sources and their capture style

The **Trigger Source** can be any external input signal inputted into the camera which is called **Hardware (Trigger Source)**, it can also be a command from the application which is called **Software (Trigger Source)**. For the **Software Trigger Source**, it can be **Single**, **Loop**, **Multiple**, or **Sequence** style. Figure 11-4 shows the possible **Trigger Sources**. Table 11-1 shows the designed **Trigger Source** descriptions and possible capture styles for EHD imaging GmbH camera.

- Isolated input
- GPIO
- GPIO1
- Counter
- PWM
- Software

Figure 11-4 Possible Trigger Sources

Table 11-1 Description of possible Trigger Sources and their capture styles

Trigger Source	Description
Isolated input	Logic 0 input level: 0~2.2VDC; Logic 1 input level: 3.3~24VDC; Maximum input current: 30mA;
GPIO0	Logic 0 input level: 0~0.6VDC (DIR_GPIO0/DIR_GPIO1 pins); Logic 1 input level: 2.0~24VDC (DIR_GPIO0/DIR_GPIO1 pins); Maximum input current: 25mA; If GPIO0 is chosen as Trigger Source , it should be configured as Input in the GPIO Mode 's combo box on the Options>IO Control page;
GPIO1	Logic 0 input level: 0~0.6VDC (DIR_GPIO0/DIR_GPIO1 pins); Logic 1 input level: 2.0~24VDC (DIR_GPIO0/DIR_GPIO1 pins);

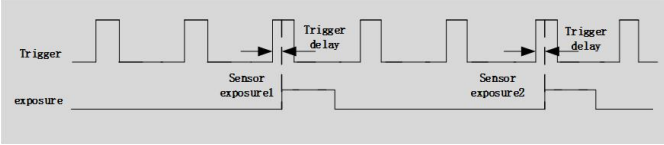
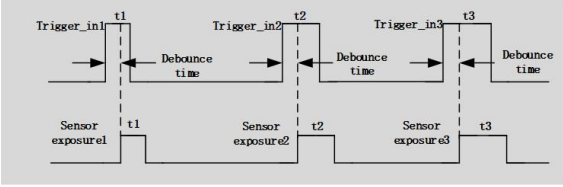
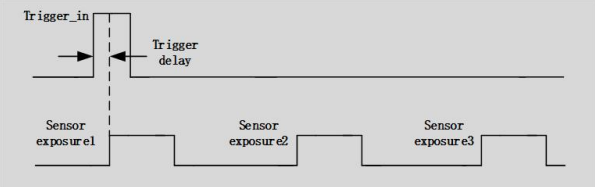
	<p>Maximum input current: 25mA; If GPIO1 is chosen as Trigger Source, it should be configured as Input in the GPIO Mode's combo box on the Options>IO Control page;</p>
<p>Counter</p>	<p>Counter refers to the operation mode in which the camera can divide the frequency of the external input trigger signal through the preset Counter Value and perform image acquisition according to the customer's logic. For example, when the counter value(Counter Value: <input type="text" value="3"/> [1,1023]) is set to 3, the camera needs to receive 3 trigger signals to trigger once;</p>  <p>When Counter is chosen in Trigger Source combo box in the Capture & Resolution group, the Counter Source can be Isolated input, GPIO0 or GPIO1 which can be chosen on Options>IO Control page; If GPIO0 or GPIO1 is chosen in the Counter Source combo box on Options>IO Control page. It should be configured as Input in the GPIO Mode combo box; Check Options>IO Control page's Line Select related items and Counter related items for details;</p>
<p>PWM</p>	<p>PWM refers to the operation mode in which the camera exposure time is controlled by the input trigger signal's pulse width;</p>  <p>PWM Trigger Source can be Isolated input, GPIO0 or GPIO1. If GPIO0 or GPIO1 is chosen in the PWM Source combo box on the Options>IO Control page, it should be configured as Input in the GPIO Mode combo box; Check Options>IO Control page's Line Select related items and PWM related items for details;</p>
<p>Software</p>	<p>When Software trigger is chosen, the client software can send the command through USB3.0 to trigger, acquire and transfer images. In EHDview, Single, Loop, Multiple, or Sequence can be used to send the Software trigger command; If the Plan or Hardware is chosen in the Type combo box on the Options>Sequence page, the Multiple button will switch to Sequence button and the camera will use the Exposure Time and Gain in the Sequence table on this page one by one to capture the specified frames. Check Single, Loop, Multiple, or Sequence on Capture & Resolution group for the Software capture operations; Check Options>Sequence page and Options>Advanced page for the related Sequence and Software capture setup options;</p>
<p>Single</p>	<p>When Single is clicked, the camera will start to capture the image. At the same time the Single button will switch to Stop button. Clicking Stop button to stop the current Single capture operation, the Stop button will switch to Single button again for the next capture operation; Note: 1) The captured frames will always Show in the video window to prevent too many captures; 2) Enabled when Software in the Trigger Source combo box is chosen or Always enable software trigger checkbox is checked on the Options>Advanced property page;</p>
<p>Loop</p>	<p>When Loop is clicked, the camera will start to capture the image continuously and the Loop button will switch to Stop button. Clicking Stop button to stop Loop captures and the Stop button will switch to Loop button for the next Loop capture operation; Note: 1)The captured frames will always Show in the video window to prevent too many captures; 2)Enabled to capture continually when Software in the Trigger Source combo box is chosen or Always enable software trigger checkbox is checked on the Options>Advanced property page;</p>
<p>Multiple</p>	<p>Multiple refers to the operation mode in which the camera receives Software trigger signal or command and export multiple frames of images. An edit box with spin(we call it Frames Box) is designed and affiliated to the Multiple button (<input type="text" value="Multiple"/> <input type="text" value="3"/> <input type="button" value="Options..."/>) for the setting of the frames to be captured; The Frames Box can be set in the range of 1~ 65535. If the Frames Box is 3, a three-frame image will be captured and exported;</p>  <p>Note: 1) Multiple capture is enabled to capture continually when Software in the Trigger Source combo box is chosen; 2) Multiple capture is enabled when Always enable software trigger is checked on the Options>Advanced property page, no matter whether Trigger Source is Software or Hardware on the Capture & Resolution group; 3) If the Plan or Hardware is chosen in the Type combo box on the Options>Sequence page, the Multiple button will switch to Sequence button and the camera will use the Exposure Time and Gain in the Sequence table on this page. The captured</p>

	frames will be displayed either in Show in the video window , or Show in a new window or Save to disk which can be specified on Options>Output page;
Sequence	<p>When Sequence is clicked, the camera will start to capture the image until the specified frames in the Frames Box are captured. At the same time the Sequence button will switch to Stop button. Clicking Stop button will stop the current Sequence capture and the Stop button will switch to Sequence again for the next Sequence capture operation;</p> <p>Note:</p> <ol style="list-style-type: none"> 1) Switched from Multiple to Sequence to capture the specified frames in the edit box with spin(Frames Box) when Plan or Hardware in the Type combo box is chosen on the Options>Sequence property page; 2) If the Plan or Hardware is chosen in the Type combo box on the Options>Sequence page, the Sequence button will be enabled and the capture will use the Exposure Time and Gain in the Sequence table list below one by one on the Options>Sequence page; 3) If the Plan or Hardware is chosen in the Type combo box on the Options>Sequence page and Always enable software trigger is checked on the Options>Advanced property page, the Sequence button will not switch to Multiple button and will be enabled only when the still in Sequence enable 4) If the Plan is chosen in the Type combo box on the Options>Sequence page and the Software is chosen in the Trigger Source combo box, the Sequence button will be enabled. 5) If the Hardware is chosen in the Trigger Source combo box, the Sequence button will be disabled, but the Frame Box will still be enabled and the Sequence will switch to the Hardware Sequence capture. One Hardware trigger signal will capture the specified frames on the Frame Box using the Exposure Time and Gain in the Sequence table on Options>Sequence page; 6) Check Options>Sequence page for the related Sequence setup options;

11.3.3 The trigger capture and IO Control configurations

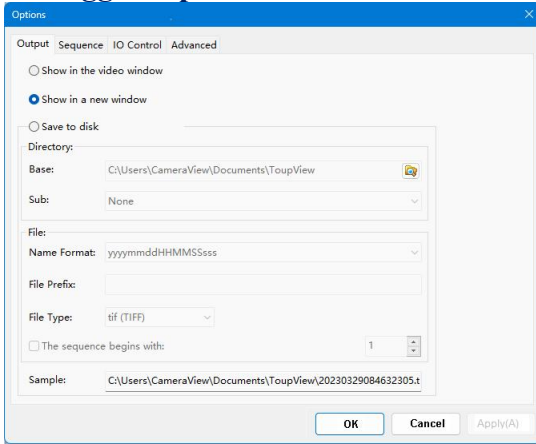

Figure 11-5 Options>Output page

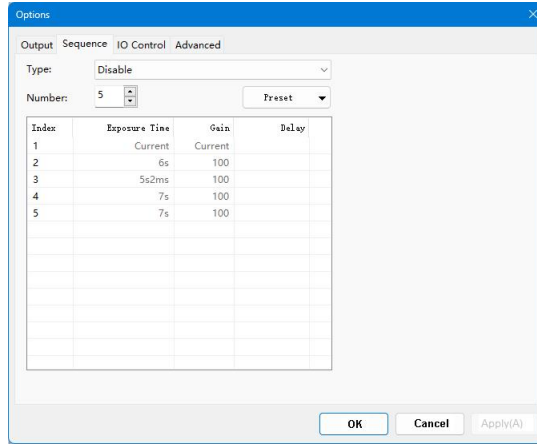

Figure 11-6 Options>Sequence page

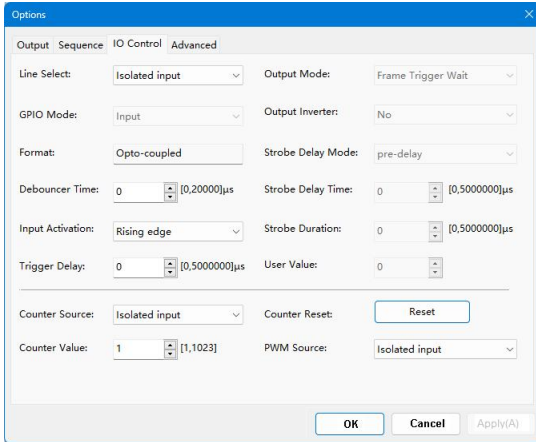

Figure 11-7 Options>IO Control page

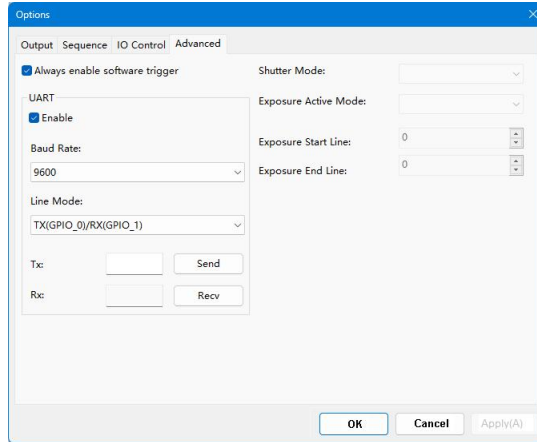

Figure 11-8 Options>Advanced page

The **Trigger Source** can be **Isolated input**, **GPIO0**, **GPIO1**(when configured as input), **Counter**, or **PWM** which can be configured on the **Options** property sheet. Also the camera's **Isolated output**, **GPIO0** or **GPIO1**(can be configured as **Output**) can be used as **Output** or **UART** (**GPIO0**, **GPIO1** only) applications. All of these configurations can be realized on the **Options** property sheet described in Table 11-2 below.









About the captured file operation style, one can find it on the [Option>Output](#) page;

About the [Sequence](#) setup, one can find it on the [Option>Sequence](#) page;

About the camera pin [IO Control](#) style, one can find it on the [Options>IO Control](#) page;

About the [Always enable software trigger](#) and [UART](#) setup, [Shutter Mode](#), and [Exposure Active Mode](#), one can find it on the [Options>Advance](#) page.

Table 11-2 Options property sheet for Trigger Source or camera pin configuration

Pages	Items	Descriptions
Output page	Output Destination	<p>Used to set the captured frame's Output destination, can be Show in the video window, Show in a new window or Save to disk;</p> <p>When Save to disk is checked, the  button will be enabled clicking it to choose the Base directory, clicking the Sub combo box's dropdown button to choose the Sub directory;</p> <p>The File Name Format, File Prefix, File Type, and even The sequence begin with can be chosen, set, or defined.</p> <p>Note: 1)Valid only for Sequence or Multiple capture setup; 2)For Single or Loop capture, the captured image will be always displayed on the video window;</p>
Sequence page	Type Disable Plan Hardware	<p>Disable: If the Disable button is chosen in the Type combo box on the Options>Sequence page, the Sequence button on the Capture & Resolution page will switch to Multiple button;</p>
		<p>Plan: 1)If Plan is chosen in the Type combo box on the Options>Sequence page, the Multiple button on the Capture & Resolution group will switch to Sequence button;</p> <p>2) If the Software Trigger Source is chosen in the Capture & Resolution group or the Always enable software trigger is checked on the Options>Advanced property page, the Sequence button will be enabled After the Software trigger signal is arrived(By clicking Single, Loop, or Sequence button), the camera will capture frames specified in the edit box with spin  3  (we call it Frames Box) affiliated to the Sequence button; The whole captures will use the Exposure Time, Gain and Delay in the Sequence table list under  3  one by one by the software;</p> <p>3) If the Disable button is chosen in the Type combo box on the Options>Sequence page, the Sequence button on the Capture & Resolution page will switch to Multiple button;</p> <p>4) The Sequence button will be enabled only when a) the Plan in the Type combo box is chosen on the Options>Sequence page and b) he Software Trigger Source is chosen in the Capture & Resolution group or c) Always enable software trigger is checked on the Options>Advanced property page;</p>
	<p>Hardware: 1) if Hardware is chosen in the Type combo box on the Options>Sequence page, the Multiple button on the Capture & Resolution group will switch to Sequence button and will be disabled for Hardware trigger. But users can still set the frames number in the Frame Box on the Capture & Resolution group;</p> <p>2) After the Hardware trigger signal arrives, the camera will capture frames specified in the edit box with spin  3  (we call it Frame Box) affiliated to the Sequence button; The whole capture will use the Exposure Time, Gain (Delay is not used) in the Sequence table list under  3  one by one but stored in the camera hardware for the quick operation;</p> <p>3) If the Disable button is chosen in the Type combo box on the Options>Sequence page, the Sequence button on the Capture & Resolution page will switch to Multiple button.</p> <p>4) The Sequence button is always disabled if a) The Hardware is chosen in the Type combo box on the Options>Sequence page and b)the Hardware Trigger Source is chosen in the Capture & Resolution group;</p> <p>5) The Sequence button will be enabled if a) the Software Trigger Source is chosen in the Capture & Resolution group or b) the Always enable software trigger checkbox is checked on the Options>Advanced property page, in this case, both the Plan and Hardware Sequence capture are supported;</p>	
	Number	The possible Sequence (capture) frames to be captured. If the Number is larger than the Sequence Number in the Frames Box on the Capture & Resolution group, the other Indices will be executed at the next Sequence operation one by one recycled;
	Index	The order of the Number group;
	Exposure Time	The camera Exposure Time for the specified capture Index in the Sequence capture;
Gain	The camera Gain for the specified capture Index in the Sequence capture;	
Delay	The Delay time for the specified capture Index in the Plan Sequence capture(Valid for Plan Sequence capture only);	
Preset	Choosing Save to save the current Sequence table 's settings; Clicking Management to Rename the saved Sequence table 's setting files or Remove them from the Management list;	

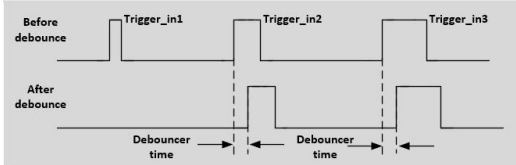
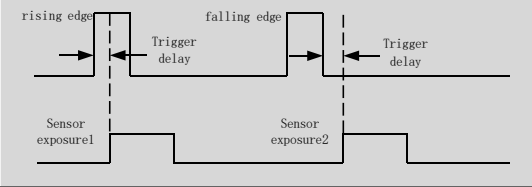
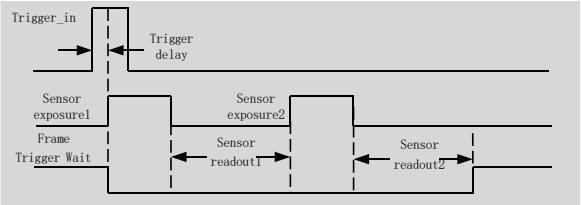
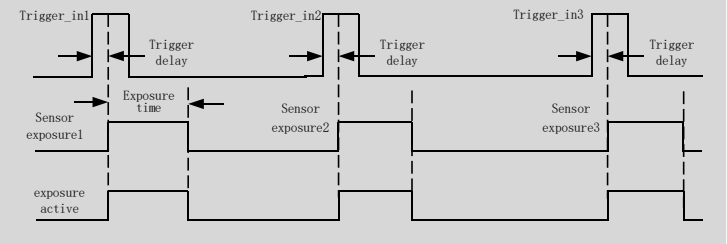
IO Control page	<p>Line Select</p>	<p>Choosing which line to set. Can be Isolated input, Isolated output, GPIO0 or GPIO1 et al;</p>
	<p>GPIO Mode</p>	<p>To configure whether the line selected in Line Select is for Input or Output. Only GPIO0 or GPIO1 can be configured as either Input or Output; If Isolated input or Isolated output is chosen, the GPIO Mode will be specified as Input or Output (Not configurable) respectively;</p>
	<p>Format</p>	<p>Specify the current selected signal's Format in the Line Select combo box, can be Opto-coupled(Isolated input, Isolated output) or TTL (GPIO0 or GPIO1) for clarity(Unconfigurable);</p>
	<p>Debouncer Time</p>	<p>Since there may be a glitch in the external trigger input signal if it directly enters into the internal logic circuit of the camera, it will cause false triggering, so the input trigger signal should be debounced. In addition, the effective pulse width of the trigger signal input by the user should be greater than the Debouncer Time, otherwise, the trigger signal will be ignored; When Isolated input, GPIO0 or GPIO1 is chosen in the Line Select combo box and GPIO0 or GPIO1 is configured as Input in the GPIO Mode combo box, the Debouncer Time will be enabled for the user to input the Debouncer Time between 0 to 20000us;</p> 
	<p>Input Activation</p>	<p>When Isolated input, GPIO0 or GPIO1 is chosen in the Line Select combo box and GPIO0 or GPIO1 is configured as Input in the GPIO Mode combo box; The Input Activation combo box will be enabled to configure the Input Activation as either Rising Edge or Falling Edge;</p> 
	<p>Trigger Delay</p>	<p>When Isolated input, GPIO0 or GPIO1 is chosen in the Line Select combo box and GPIO0 or GPIO1 is configured as Input in the GPIO Mode combo box, the Trigger Delay will be enabled for the user to input the Trigger Delay time between 0 to 5000000us; If the Trigger Delay time is set to 1000000us, the camera will wait for 1s to capture the image after receiving the trigger signal;</p>
<p>Output Mode Frame Trigger Wait Exposure Active Strobe User Output</p>	<p>When Isolated output, GPIO0 or GPIO1 is selected in the Line Select combo box and GPIO0 or GPIO1 is configured as Output in the GPIO Mode combo box, the Output Mode will be enabled. It can be Frame Trigger Wait, Exposure Active, Strobe, or User Output. The chosen mode can be used for diversified applications; The Frame Trigger Wait signal is pulled low at the start of exposure and pulled high when the last frame of data is read out. The trigger signal input by the user should be in the valid period. If the user inputs a trigger signal when the signal is low, the trigger signal input at this time will be ignored. The following example is the case when Burst Count = 2, as shown below;</p>  <p>ExposureActive: when this signal is high, it means the sensor is exposing. This signal can be used to control an external mobile device to remain stationary or move at low speed while the camera is at exposure. The timing diagram of the exposure valid signal is shown below;</p>  <p>When the relative position of the camera and the object to be photographed changes, you can refer to Exposure Active</p>	

		<p>signal to prevent the captured image from being affected by movement and focus adjustment during the exposure process;</p> <p>When Strobe is chosen, Strobe Delay Mode, Strobe Delay Time, Strobe Duration will be enabled;</p> <p>When User Output is chosen, User Value will be enabled. lines3, line2, line1 are the combination of GPIO1, GPIO0 and Isolated output respectively. If User Value is 001, then line GPIO1 and GPIO0 will be disabled and Isolated output will be enabled;</p> <div data-bbox="841 352 1084 443" style="border: 1px solid black; padding: 5px; margin: 10px auto; width: fit-content;"> <table style="border-collapse: collapse; text-align: center;"> <tr> <td style="padding: 2px;">UserOutput</td> <td colspan="3" style="padding: 2px;">Value:</td> </tr> <tr> <td style="padding: 2px;"></td> <td style="border: 1px solid black; width: 20px; height: 20px; text-align: center;">1</td> <td style="border: 1px solid black; width: 20px; height: 20px; text-align: center;">0</td> <td style="border: 1px solid black; width: 20px; height: 20px; text-align: center;">0</td> </tr> <tr> <td style="padding: 2px;"></td> <td style="padding: 2px;">Line:</td> <td style="padding: 2px;">line3</td> <td style="padding: 2px;">line2</td> <td style="padding: 2px;">line1</td> </tr> </table> </div>	UserOutput	Value:				1	0	0		Line:	line3	line2	line1
UserOutput	Value:														
	1	0	0												
	Line:	line3	line2	line1											
<p>Output Inverter</p>		<p>When Isolated output, GPIO0 or GPIO1 is selected in the Line Select combo box and Output is chosen for GPIO0 or GPIO1 in the GPIO Mode combo box, the Output Inverter will be enabled to configure the current selected line's output as either inverted or not(Yes or No).</p>													
<p>Strobe Delay Mode</p>	<p>Delay</p>	<p>Strobe can be used to control external devices such as the strobe, and the effective level duration, delay time, and pre-delay time of the strobe signal can be set;</p> <p>When the Output Mode is Strobe, Strobe Delay Mode will be enabled. It can be pre-delay or delay;</p>													
<p>Strobe Delay Time</p>	<p>Delay</p>	<p>When exposure starts, the strobe does not take effect immediately, and the output is delayed according to the value set by Strobe Delay Time which is between 0 to 5000000us. The Strobe Delay Mode can be pre-delay or delay; It is described below;</p> <p>pre-delay:</p> <div data-bbox="589 722 1336 968" style="border: 1px solid gray; padding: 5px; margin: 10px auto; width: 80%;"> </div> <p>delay:</p> <div data-bbox="589 1003 1336 1247" style="border: 1px solid gray; padding: 5px; margin: 10px auto; width: 80%;"> </div>													
<p>Strobe Duration</p>		<p>The high level duration of the strobe is determined by the Strobe Duration which is between 0 to 5000000us as shown below;</p> <div data-bbox="589 1308 1336 1549" style="border: 1px solid gray; padding: 5px; margin: 10px auto; width: 80%;"> </div>													
<p>User Value</p>		<p>Users can input a value at User Value edit box with spin to control the line as disable or enable. Enabled when User Output is chosen in the Output Mode combo box. The logical value 0 or 1's combination of GPIO1(line3), GPIO0(line2) and Isolated output(line1);</p> <p>When the output mode is selected as User Output, the user can input a value at User Value edit box to control the corresponding line output with 0 or 1;</p> <p>The value here is only valid for the lower three bits of a binary. For example, when line 1 and line 3 are set to User Output mode, and its User Value is set to 4 ('b100), then line 3 outputs 1, and line 1 outputs 0, as shown below.</p> <div data-bbox="841 1749 1084 1839" style="border: 1px solid black; padding: 5px; margin: 10px auto; width: fit-content;"> <table style="border-collapse: collapse; text-align: center;"> <tr> <td style="padding: 2px;">UserOutput</td> <td colspan="3" style="padding: 2px;">Value:</td> </tr> <tr> <td style="padding: 2px;"></td> <td style="border: 1px solid black; width: 20px; height: 20px; text-align: center;">1</td> <td style="border: 1px solid black; width: 20px; height: 20px; text-align: center;">0</td> <td style="border: 1px solid black; width: 20px; height: 20px; text-align: center;">0</td> </tr> <tr> <td style="padding: 2px;"></td> <td style="padding: 2px;">Line:</td> <td style="padding: 2px;">line3</td> <td style="padding: 2px;">line2</td> <td style="padding: 2px;">line1</td> </tr> </table> </div>	UserOutput	Value:				1	0	0		Line:	line3	line2	line1
UserOutput	Value:														
	1	0	0												
	Line:	line3	line2	line1											
<p>Counter Source</p>		<p>When Counter is chosen in the Trigger Source combo box in the Capture & Resolution group, the Counter Source can be chosen from Isolated input, GPIO0 or GPIO1 in this combo box on the Option>IO Control page;</p>													

	Counter Value	The Counter Value is used to divide the frequency of the external input trigger signal when the Counter Trigger Source is chosen in the Capture & Resolution group; See Counter in Table 11-1 for detail;
	Counter Reset	Click Reset button can clear the current counting process and begin a new one;
	PWM Source	When PWM is chosen in the Trigger Source combo box in the Capture & Resolution group, the PWM Source can be from Isolated input, GPIO0, or GPIO1 in this combo box et al. ;
Advanced page	Always enable software trigger	When this button is checked, no matter whether Trigger Source is Software or Hardware , the software trigger buttons(Single, Loop, Multiple) are always enabled; If the Plan or Hardware is chosen in the Type combo box on the Options>Sequence page, the Multiple button will switch to Sequence button; The Sequence button will be enabled if a)the Software Trigger Source is chosen in the Capture & Resolution group or b) the Always enable software trigger checkbox is checked on the Options>Advanced property page, in this case, both the Plan and Hardware Sequence captures are supported;
	UART	There is a serial port function on the Advanced page, which can be used to communicate with external devices via serial port. Check Enable to enable this function. When enabled, GPIO0 and GPIO1 can only be used as UART transfers; The Baud Rate support 9600-115200. Cable Select can configure GPIO0 and GPIO1 , which can be configured as TX or RX respectively. Setting a value at TX , clicking Send to send the set value out; click Accept at RX to receive the value from the external device;
	Shutter Mode	Enabled if the camera support. Users can select Rolling Shutter or Global Reset ;
	Exposure Active Mode	Enabled if the camera support. Users can select Specified lines or Common exposure time ;
	Exposure Start Line	Enabled when Specified lines in the Exposure Active Mode combo box is selected. To configure when the Exposure Active signal is valid;
	Exposure End Line	Enabled when Specified lines in the Exposure Active Mode combo box is selected. To configure when the Exposure Active signal is invalid;

11.4 Cooling

There is a **Cooling** group on the left sidebar in EHDview. To enable the **Cooling** function, an external 12V power supply is required. By default, the **TEC** is turned on. One can set the **Target Temperature**. After entering the value, click "**Apply**", and the sensor temperature will gradually approach to the **Target Temperature**. At the same time, EHDview can display the current temperature in real time. And the cooling effect can reach about 10-25 degrees lower than the ambient temperature, as shown in Figure 11-9.

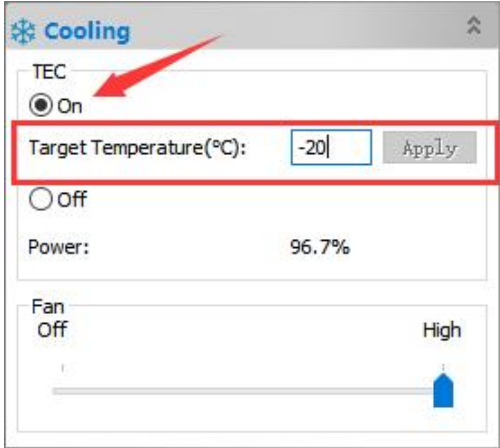

Figure 11-9 TEC settings

The **Fan** has two gears from **Off** to **High**. When **High**, the **Fan** speed reaches the highest. When **Off**, the **Fan** is turned off, the **TEC** is also turned off, and the power is 0, as shown in Figure 11-10.

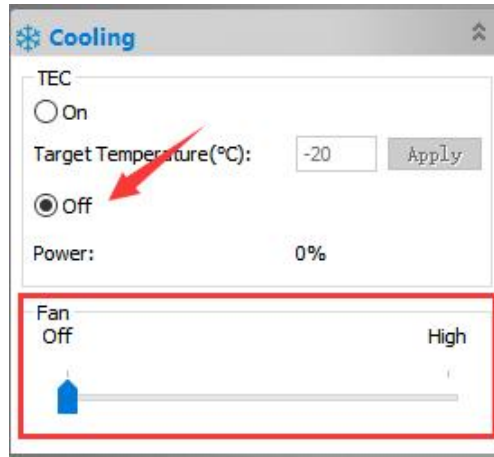

Figure 11-10 Fan settings

When the **TEC** is turned on, the **Fan** will automatically turn on preventing the abnormal situation such as the housing temperature is too high if the **Fan** stops running when the **TEC** is working; when the **Fan** is turned off, the **TEC** will automatically turn off.

11.5 Software development instructions

11.5.1 SDK description

The download link of the SDK is as follows:

www.ehd.de/driver

11.5.2 SDK support platform

- Win32:
 - x86: XP SP3 and above; the CPU needs to support at least the SSE2 instruction set.
 - x64: Win7 and above.
 - arm: Win10 and above.
 - arm64: Win10 and above.
- WinRT: x86, x64, arm, arm64; Windows 10 and above.
- macOS: x86 and x64 bundle; macOS 10.10 and above.
- Linux: core 2.6.27 and above.
 - x86: The CPU needs to support at least the SSE3 instruction set; GLIBC 2.8 and above.
 - x64: GLIBC 2.14 and above.
 - armel: GLIBC 2.17 and above; compiled by toolchain arm-linux-gnueabi (version 4.9.2).
 - armhf: GLIBC 2.17 and above; compiled by toolchain arm-linux-gnueabi (version 4.9.2).
 - arm64: GLIBC 2.17 and above; compiled by toolchain aarch64-linux-gnu (version 4.9.2).
- Android: arm, arm64, x86, x64; compiled by android-ndk-r18b.

11.5.3 Introduction to SDK content

EHDcam series cameras support a variety of APIs, including: Native C/C++, .NET/C#/VB.NET, Python, Java, DirectShow, Twain, LabView, Matlab, etc. Compared with other APIs, Native C/C++ API as a low-level API is characterized by using pure C/C++ development without relying on other runtime libraries. The interface is simple and the control is flexible. This SDK zip package contains all the resources and information needed. The directory is as follows:

- inc:

nncam.h, the C/C++ header file.

- win: Microsoft Windows platform file
 - ◆ dotnet:

nncam.cs, support C#. nncam.cs uses P/Invoke to call nncam.dll. Please copy nncam.cs to your C# project for use.

nncam.vb, support VB.NET. nncam.vb uses P/Invoke to call nncam.dll. Please copy nncam.vb to your VB.NET project for use.

- ◆ x86:

nncam.lib, x86 lib file.

nncam.dll, x86 dynamic library file.

democpp.exe, x86 C++ demo execute the procedure.

- x64:

nncam.lib, x64 lib file.

nncam.dll, x64 dynamic library file.

democpp.exe, x64 C++ demo execute the procedure.

- arm:

nncam.lib, arm lib file.

nncam.dll, arm dynamic library file.

- arm64:

nncam.lib, arm64 lib file.

nncam.dll, arm64 dynamic library file.

- winrt:

They can be applied for Dynamic library files of WinRT/ UWP (Universal Windows Platform)/ Windows Store App. They are compatible with Windows Runtime and can be referenced by Universal Windows Platform apps. If you use C# to develop UWP, you can use the nncam.cs wrapper class.

Please pay attention to the Device Capability of uwp. Refer to how to add USB device capabilities to the app manifest. (Microsoft seems to limit the Device entry under DeviceCapability to no more than 100) demouwp.zip is a simple example of uwp. Please modify vid and pid. under DeviceCapability in the file Package.appxmanifest before compiling the run example.

- Drivers: (Cameras produced after 2017.1.1 support WinUSB, and drivers no longer need to be installed on Windows 8 and above)

The x86 folder contains the x86 kernel-mode driver files, including nncam.cat, nncam.inf and nncam.sys.

The x64 folder contains the x64 kernel-mode driver files, including nncam.cat, nncam.inf and nncam.sys.

- samples:

1. democpp, C++ example. This example demonstrates enumerating devices, opening devices, previewing videos, capturing images, setting resolution, triggering, saving images to files in various image formats (.bmp, .jpg, .png, etc.), wmv format video recording, Trigger Mode/Trigger Mode, IO control and so on. This example uses the Pull Mode mechanism. To keep the code clean, the WTL library used by the examples can be downloaded from this link <http://sourceforge.net/projects/wtl/>.

2. demopush, C++ example, using the Push Mode mechanism, StartPushModeV3.

3. demomfc, a simple C++ example, uses MFC as a GUI library, support opening devices, previewing

videos, capturing images, setting resolution, saving images to files in various image formats (.bmp, .jpg, .png, etc.), etc. This example uses the Pull Mode mechanism.

4. demowinformcs1, take C# winform for example, it support opening devices, previewing videos, capturing images, saving images to files, and setting white balance. This example uses the Pull Mode mechanism, StartPullModeWithWndMsg.

5. demowinformcs2, take C# winform for example, it support opening devices, previewing videos, capturing images, saving images to files, and setting white balance. This example uses the Pull Mode mechanism, StartPullModeWithCallback.

6. demowinformcs3, take C# winform for example, it support opening devices, previewing videos, capturing images, saving images to files, and setting white balance. This example uses the Push Mode mechanism, StartPushMode.

7. demowinformvb, take VB.NET winform for example, it support opening devices, previewing videos, capturing images, saving images to files, and setting white balance. This example uses the Pull Mode mechanism.

- linux: Linux platform files

Udev: 99-nncam.rules, udev rule file.

Please refer to: http://reactivated.net/writing_udev_rules.html.

- c#: nncam.cs, Support. Net Core C#. nncam.cs uses P/Invoke to call libtoupcam.so. Please copy nncam.cs to your C# project for use.
- x86: libtoupcam.so, x86 version so file.
- x64: libtoupcam.so, x64 version so file.
- armel: libtoupcam.so, armel version so file, toolchain is arm-linux-gnueabi.
- armhf: libtoupcam.so, armhf version so file, toolchain is arm-linux-gnueabi.
- arm64: libtoupcam.so, arm64 version so file, toolchain is aarch64-linux-gnu.
- android: libtoupcam.so for four architectures of Android platform arm, arm64, x86, x64.
- mac: macOS platform files.
- python: nncam.py and example code.
- java: nncam.java and example code (console and Swing).
- doc: SDK usage documentation, Simplified Chinese, English.
- sample:

demosimplest, the simplest example, is about 60 lines of code.

demoraw, RAW data and still shots, about 120 lines of code.

11.5.4 Third-party interface software

- directshow: DirectShow SDK and demo program.
- twain: TWAIN SDK.
- labview: Labview SDK and demo program.
- matlab: MatLab demo program.

12 CameraLink Camera Application

12.1 Connection to the CameraLink

Connect the two CameraLink cables: the CameraLink1 port on the camera is connected to the CL1 port on the capture card, the CameraLink2 port on the camera is connected to the CL2 port on the capture card.

Attention: if the camera and the acquisition card cross-linking, camera will not work. Please pay special attention.

12.2 Software installation

12.2.1 Install SDK

Windows 10 system can directly select the exe shown in Figure 12-1 to install SDK; For Windows 7, please install the driver shown in Figure 12-2.

名称	修改日期	类型	大小
SaperaLTSDKSetup_8.60.exe	2023/4/28 13:49	应用程序	413,617 KB
Xtium2-CL MX4.pdf	2023/4/28 13:59	Microsoft Edge ...	4,426 KB
xtium-cl_mx4_130000311.exe	2023/4/28 13:49	应用程序	43,574 KB

Figure 12-1

SaperaLTSDKSetup_8.60.exe	2023/4/28 13:49	应用程序	413,617 KB
Windows6.1-KB3033929-x64.msu	2023/8/24 10:37	Microsoft 更新独...	44,843 KB
Xtium2-CL MX4.pdf	2023/4/28 13:59	Microsoft Edge ...	4,426 KB
xtium-cl_mx4_130000311.exe	2023/4/28 13:49	应用程序	43,574 KB

Figure 12-2

12.2.2 Install options

The following is the interface to be selected, and the rest of the steps can be directly clicked next.

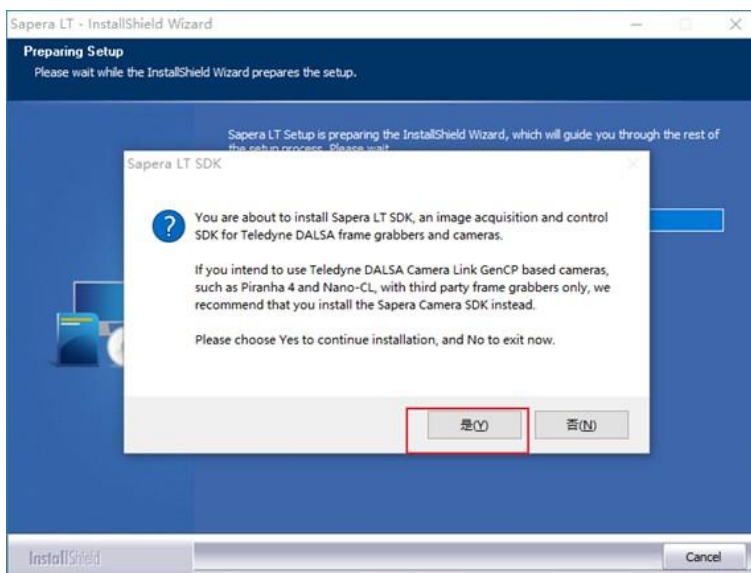

Figure 12-3

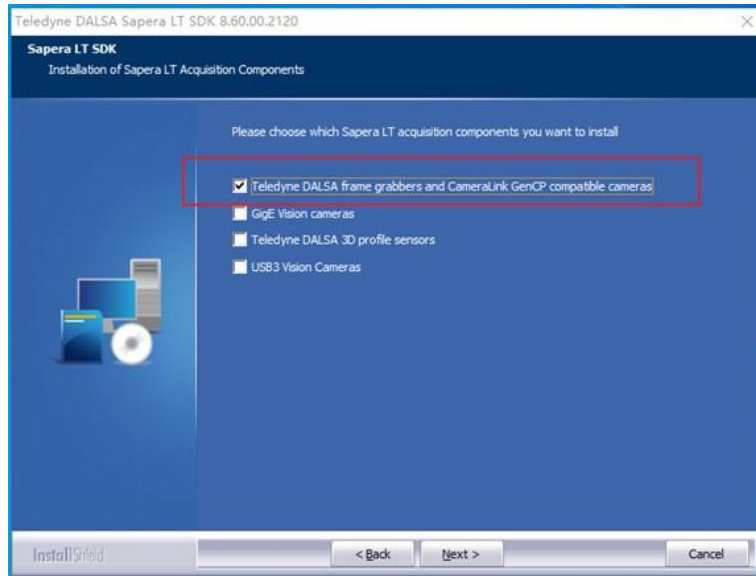

Figure 12-4

12.2.3 Install the driver

The exe shown in Figure 12-5 is the driver of the capture card (xtium-cl_mx4) currently used by our company, and Drivers vary by DALSA capture card model.

Follow the installation wizard and click Next for all steps.

SaperaLTSDKSetup_8.60.exe	2023/4/28 13:49	应用程序	413,617 KB
Xtium2-CL MX4.pdf	2023/4/28 13:59	Microsoft Edge ...	4,426 KB
xtium-cl_mx4_130000311.exe	2023/4/28 13:49	应用程序	43,574 KB

Figure 12-5

Restart your computer after the installation is complete.

12.3 Configure the Dalsa capture card

12.3.1 Serial port configuration

Find the software Sapera Configuration in Figure 12-6 of the DALSA supporting tool, open it, change COM port mapping (optional) to the required port (currently COM2) as shown in Figure 12-7, and restart the computer according to the program requirements.

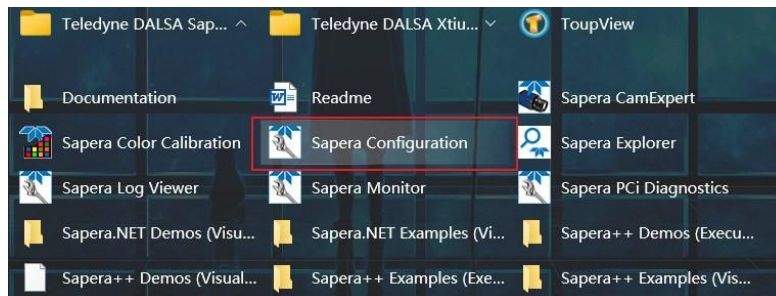

Figure 12-6

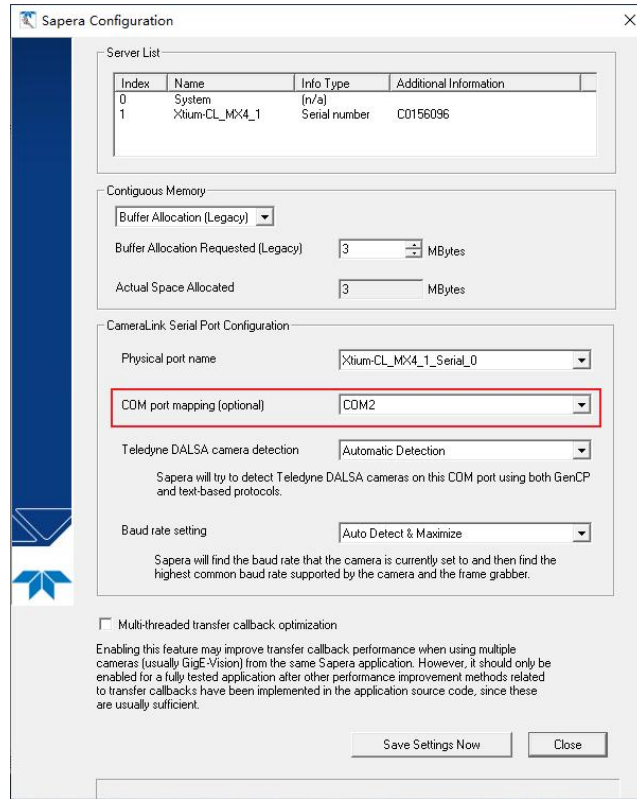

Figure 12-7 Serial port configuration dialog box

12.3.2 CameraLink mode configured

Open the software in Figure 12-8 and verify that it looks like Figure 12-9. If not, please click the Manual button in Figure 20 to modify the tart as shown in Figure 12-10, and click the Start Updat button to wait for the completion of the update. If an error occurs, please confirm whether the serial port control is turned off.

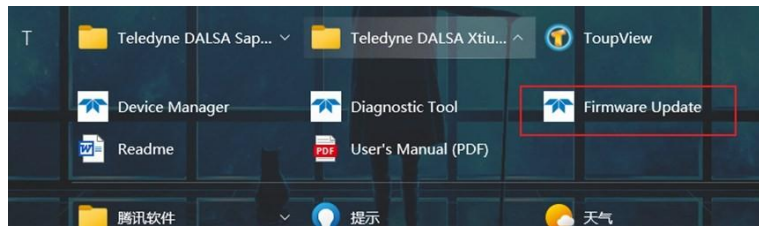

Figure 12-8

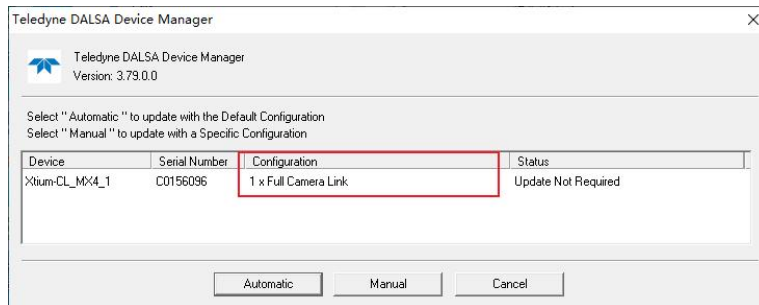

Figure 12-9

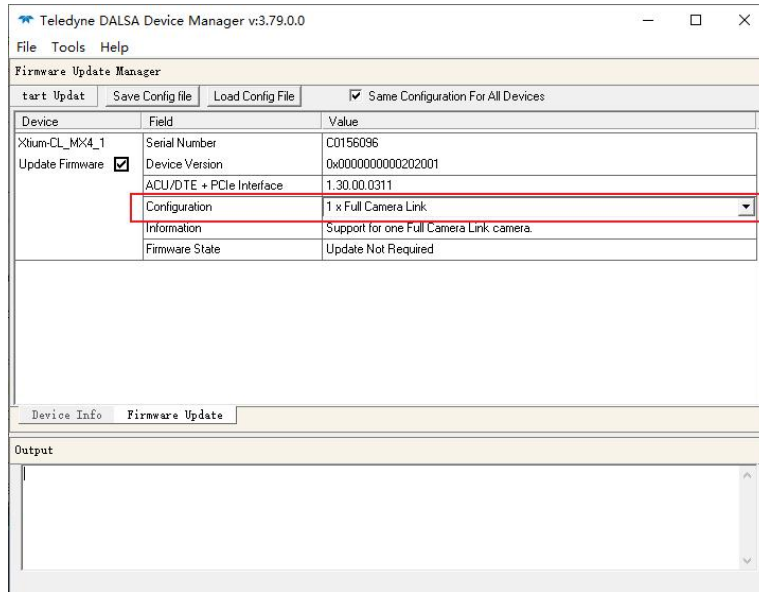

Figure 12-10

12.3.3 Configuring CameraLink Receiving

Opening the Spera CamExpert software of DALSA, click the arrow position in Figure 12-11 and select SWIR331KMA_CL_Medium_12bit_4Ports_640x512_V1.0.ccf to load the configuration information of the receiving format of CameraLink.

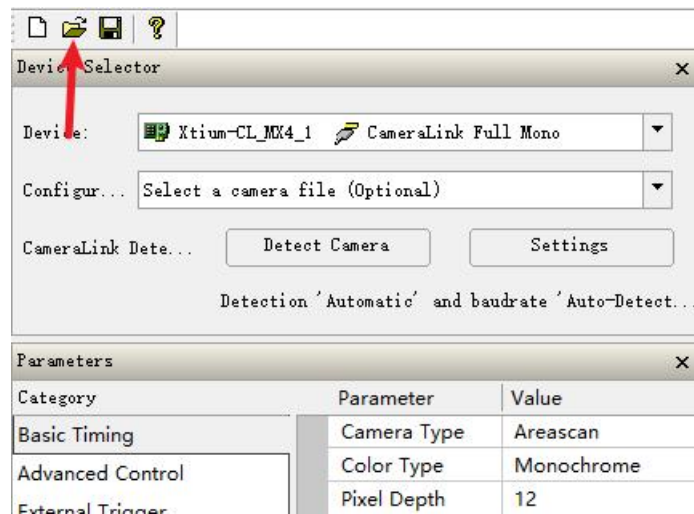

Figure 12-11 Load the CameraLink receive format configuration information

The arrangement is shown in Figure 12-12(You do not need to change the arrangement of the ccf files mentioned above).

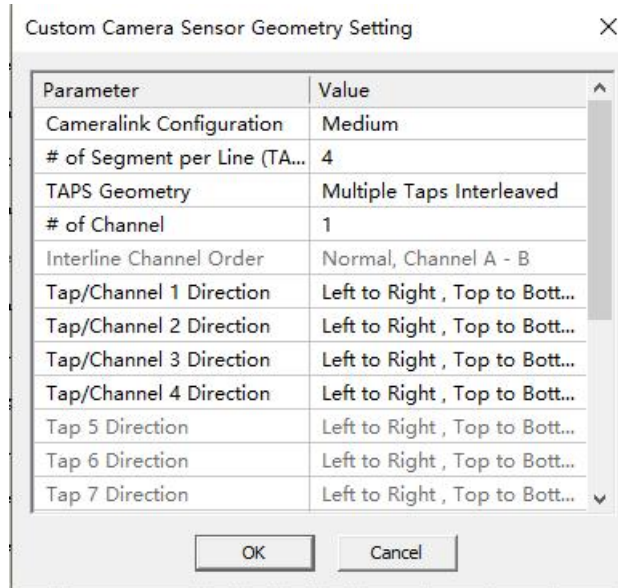

Figure 12-12 Arrangement

12.3.4 CameraLink Receiving the configuration content

The image below shows the resolution and bit depth Settings.

Parameter	Value
Camera Type	Areascan
Color Type	Monochrome
Pixel Depth	12
Horizontal Activ...	640
Horizontal Offs...	0
Vertical Active (...)	512
Vertical Offset (...)	0
Pixel Clock Inp...	85
Data Valid	Disabled
Camera Sensor...	Custom
PoCL	Disabled
PoCL Status	Not Active

Figure 12-13

The steps of Camera Sensor Geometry Setting are shown in Figure 12-14 and Figure 12-15.

Parameter	Value
Camera Type	Areascan
Color Type	Monochrome
Pixel Depth	12
Horizontal Ac...	640
Horizontal Of...	0
Vertical Active...	512
Vertical Offse...	0
Pixel Clock In...	85
Data Valid	Disabled
Camera Sens...	Custom
PoCL	Disabled
PoCL Status	Not Active

Figure 12-14

Camera Sensor Geometry Setting

GenICam	Description	Diagram	Demo
1X-1Y	One Tap Left to Right	A →	Demo
1X-1Y2	Two Interline Channel, Even A	A → B →	Demo
1X-1Y2	Two Interline Channel, Even B	B → A →	Demo
1X-2YE	Two Channel Converge	A → ↓ B →	Demo
2X-1Y	Two Taps Separate Left to Right	A → B →	Demo
3X-1Y	Three Taps Separate Left to Right	A → B → C →	Demo
4X-1Y	Four Taps Separate Left to Right	A → B → C → D →	Demo
8X-1Y	Eight Taps Separate Left to Right [4 zones in X, 1 zone in Y]	A → B → C → D → E → F → G → H →	Demo
10I-1Y	Ten Taps Separate Left to Right	A → B → C → D → E → F → G → H → I → J →	Demo
1X2-1Y	Two Taps Interleaved	A B A B →	Demo
1X3-1Y	Three Taps Interleaved	A B C A B C →	Demo
2X2-1Y	Four Taps Two Segments Interleaved	A B A B → C D C D →	Demo
1X0-1Y	Right Taps Interleaved	A B C D E F G H →	Demo
2XE-1Y	Two Taps Separate Converge	A → ← B	Demo
2XM-1Y	Two Taps Separate Diverge	← A B →	Demo
2X2E-1Y	Four Taps Interleaved Converge	A B A B → ← C D C D	Demo
2XE-2YE	Four Quadrant Converge	A → ← B ↓ ↓ C → ← D	Demo
Custom	Custom Configuration	Setting	

OK Cancel

Figure 12-15

The Settings are as follows:

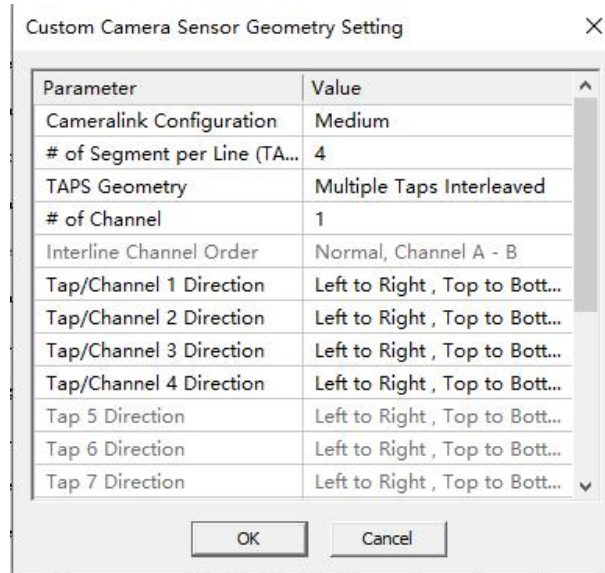

Figure 12-16

12.4 Using GenICam

12.4.1 Communication Settings

Enter the interface shown in Figure 12-17 and set the content as shown in Figure 12-18.

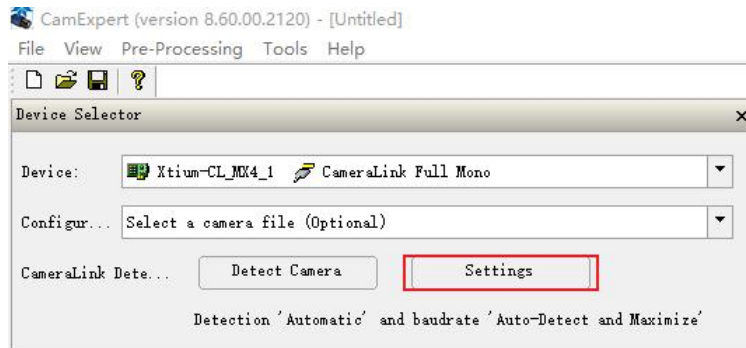

Figure 12-17

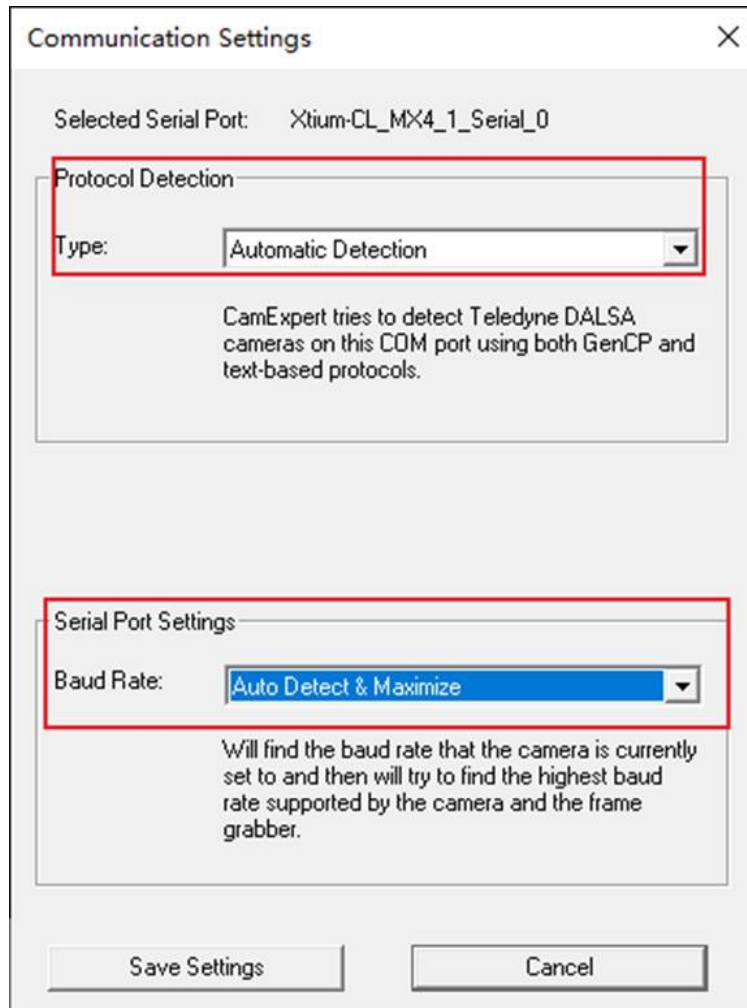

Figure 12-18

After the Settings are complete, properly connect the camera and restart CamExpert. Figure 12-19 will appear on the software interface.

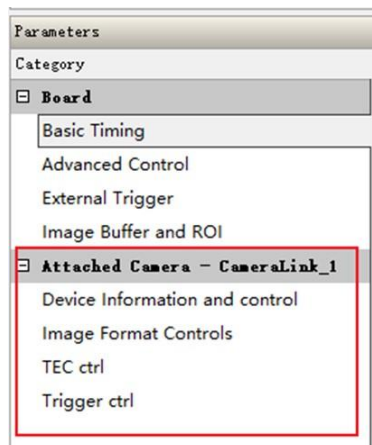

Figure 12-19

12.5 Description of GenICam

12.5.1 Device Information and control

As shown in Figure 12-20, it contains the basic information of the equipment, including exposure time control, gain control, frame rate control and TEC temperature display.

Category	Parameter	Value
Board	Manufacturer ...	touptek hangzh
Basic Timing	Device Family	toupswir
Advanced Control	Model Name	toupswir331k
External Trigger	Serial Number	...
Image Buffer and ROI	expo time	100
Attached Camera - ...	gain	Middle Gain
Device Information and ...	Frame Frequency	700
Image Format Controls	Deniose mode ...	Enable
TEC ctrl	Deniose level	5
Trigger ctrl	TEC_temp	0.4
		Show More >>

Figure 12-20

12.5.2 Image Format Controls

Figure 12-21 shows the ROI control.

Parameters		
Category	Parameter	Value
Board	Horizontal Offset	0
Basic Timing	Vertical Offset	0
Advanced Control	Width	640
External Trigger	Height	512
Image Buffer and ROI		Show More >>
Attached Camera - CameraLink_1		
Device Information and control		
Image Format Controls		
TEC ctrl		
Trigger ctrl		

Figure 12-21

12.5.3 TEC Ctrl

As shown in Figure 12-22, TEC Ctrl contains TEC temperature control, TEC switch, fan switch, and TEC temperature display in degrees Celsius.

Category	Parameter	Value
Board	set temp	0.0
Basic Timing	TEC mode select	Enable
Advanced Control	Fan mode select	Enable
External Trigger	TEC_temp	-1.5
Image Buffer and ROI	Show More >>	
Attached Camera - ...		
Device Information and ...		
Image Format Controls		
TEC ctrl		
Trigger ctrl		

Figure 12-22

12.5.4 Trigger ctrl

The trigger control content Settings are shown in Figure 12-23 and contain the basic trigger Settings.

Category	Parameter	Value
Board	Tri mode	Disable
Basic Timing	Softalways	Disable
Advanced Control	TriSource	Opt_in
External Trigger	TriActivation	rising edge
Image Buffer and ROI	Burst Counter	0
Attached Camera - ...	CounterSource	Opt_in
Device Information and ...	Counter Value	0
Image Format Controls	PWMSource	Opt_in
TEC ctrl	Soft trigger	Disable
Trigger ctrl	Triggrer Delay0	0
	Triggrer Delays	0
	Output Mode0	0
	DurationTime	0
	PreDelay	0
	OutputDelay	0
	UserValue	Opt_in
	TriProhibited	4100
	Counter Reset	Disable
	Debounce0	0
	Line Inverter	-Invalid value-
	OutputCounter	1

Figure 12-23

12.6 The main features of camera

Function	Function description
Operating mode	Operating mode: video mode or trigger mode Trigger mode: soft trigger mode or external trigger mode
GenICam	Supports the standard GenICam protocol and can control the camera through third-party software

Serial port control	Support the virtual serial port of the CameraLink capture card to control the camera, and the camera command is open
Denoise	The camera hardware incorporates denoise
Bit depth	Built-in 14bit ADC, output 12bit or 14bit valid data
Automatic exposure	Automatic exposure or manual exposure function
Gain	HG, MG, LG 3 gain modes
Frame rate	Supports precise frame rate control
ROI	Supports single-zone ROI with a maximum frame rate of 8000fps after ROI
Flip	Supports Vertical/horizontal flip
Custom dark field correction	The hardware supports up to 12 groups of user-defined dark field correction image functions
Timestamp function	Timestamps can be turned on or off. After the timestamp function is enabled, the low 8bits of 1-8 pixels, 9-16 pixels, and 17-24 pixels will be modified to: 0-7: frame number; 8-15: Frame time; 16-23: trigger signal count
Firmware update	Supports firmware online update
Pipette function	Supports the display of the gray value of the mouse pixel position
Histogram display	Supports histogram display and statistics
Plane line function	Supports the function of viewing surface data
Regional gray statistics	Support the average gray statistics function of user-defined areas
DC12V power supply and cooling system	1) When the DC12V power supply is disconnected and only the CameraLink cable is connected, the camera cannot work; 2) Connect the 6PIN aviation plug interface of the DC12V adapter to the DC12V interface on the camera. After the power is successfully turned on, the two LED lights will light up; 3) The cooling system of the camera is divided into TEC cooling sheets built in the sensor, using external heat dissipation structure and fan auxiliary heat dissipation, the working temperature can be adjusted to a specific value, the effective cooling temperature can be lower than the ambient temperature of 40°C, and the high-efficiency cooling system ensures extremely low dark current level; 4) The TEC system adopts PID algorithm control, so that TEC can accurately adjust the sensor to the target temperature, and the temperature deviation is 0.3°C;
Acquisition card adaptation	Support mainstream brand CameraLink capture card, through the virtual serial port control, there are two ways: 1) The standard GenICam protocol is used to control the acquisition card software; 2) Capture card software is used to capture and display images, and CLCtrl software is used for control.

12.7 Camera Commands

12.7.1 Basic Formats

The serial port of the camera CameraLink is used as the communication port. The baud rate of the serial port is 115200, and the serial port has 8 bits without check bit mode.

The protocol format is compatible with GENICAM gencp 1.0. For details, refer to GENICAM protocol.

The protocol instruction is realized by register access, each function is distinguished and defined by different register addresses, and the protocol data is divided into general part and special part. The protocol data is preceded by the general part and followed by the special part. The general part is fixed to the length of 16 bytes, and the length of the special part is variable according to the different length of the function.

The general 16-byte format is described as follows (all fields in the general part are in Big-Endian format with high bytes before them) :

Suppose the sixteen bytes of data are D0, D1, D2, D3, D4, D5, D6, D7, D8, D9, D10, D11, D12, D13, D14, D15. For command execution, the protocol stipulates that the host computer is the active initiator and the device is the passive responder.

1. D0, D1 is two prefix bytes, fixed as 0×01 and 0×00.
2. D2 and D3 are the check words of the universal partial data. The check part ranges from D6, D7 to D14, and D15 adopts double-byte CRC redundancy check, with the high byte coming first (Big-Endian).
3. D4 and D5 are the check words for the total protocol data. The check part runs from D6 and D7 to the end of the entire protocol data. Double-byte CRC redundancy check is also adopted, with the high byte in the front (Big-Endian).
4. D6 and D7 are channel ids. At present, the device channel is fixed to 0, and the data is 0×00 and 0×00.
5. D8 and D9 are common flag fields. For the upper computer, if the value is 0×40, 0×01 indicates that the normal function request is sent and the device needs to respond. If the value is 0×00, 0×01 indicates that the normal function request is sent and the device does not need to respond. For the response of the device, the

field is 0×00. 0×00 indicates that the device receives the response correctly and there is no exception.

6. D10 and D11 are command ids, which are general command definition fields. For the upper computer, the values are 0×08 and 0×00 when reading data and 0×08 and 0×02 when writing data. For the device, the value is 0×08, 0×01 when it responds to read data, 0×08, 0×03 when it responds to write data.
7. D12, D13 indicates the length of the dedicated part data.
8. D14 and D15 are sequence ids. For the upper computer, the sequence ID needs to be increased by one for each command sent. The sequence ID remains the same for a device-side response to ensure that the host machine receives confirmation that the device-side instruction is executed correctly.

12.7.2 Dedicated Part Format

For the special part of the format is mainly divided into two read and write registers (register and length field is fixed in the Big-Endian format before the high byte, the rest of the data can be Big-Endian or Little-Endian, according to the custom)

1. Format description of the special part when the upper computer reads the register data

The whole dedicated data length is 12 bytes, if the data is R0, R1, R2, R3, R4, R5, R6, R7, X0, X1, X2, X3, where R0~R7 is the register address that needs to be read; X0, X1 is fixed to 0×00, 0×00; X2, X3 are the length of the data to be read (the length is the legal length defined by the register, and the length of each register is specified).

2. Format description of the special part when the device responds to the upper computer reading register data

The whole private data is the data that needs to be read, there are no other fields; The length varies according to the length of the data read, such as X1, X2, X3. Xn; The length of the read data is n.

3. Format description of the special part of the upper computer when writing register data

When the upper computer writes register data, the special part of the data consists of two parts: register and data, such as R0, R1, R2, R3, R4, R5, R6, R7, X1, X2, X3.....Xn; R0 to R7 indicates the register address (REG_ADDR). X1 to Xn indicates the data to be written. The length of the data to be written is n, which is the legal length specified by the register.

4. Format description of the special part when the device responds to the host computer to write register data

When the device successfully writes data from the host computer, the dedicated data part of the device response is fixed as 0×00, 0×00, 0×00, 0×00.

12.7.3 Definition of each register

ADDR_BASE = 0×0000000020000000

REG_ADDR = ADDR_BASE + ADDR_OFFSET

Number	Register function	Register address (ADDR_OFFSET)	Register value	default parameters	data length	R/W	Data sequence
1	ROI columns	0×070	32 to 640- Column start position	0	4byte	RW	little
2	ROI column starting position	0×080	0~608	640	4byte	RW	little
3	ROI rows	0×090	4 to 512- The starting position of the line	0	4byte	RW	little
4	ROI row starting position	0×0A0	0~508	512	4byte	RW	little
5	Exposure	0×200	16~100000(us)	100	4byte	RW	Big
6	Gain	0×210	0/1/2(Hg/Mg/Lg)	1	4byte	RW	Big
7	Frame rate control	0×230	1~700	700	4byte	RW	Big
8	Denosing level	0×280	1~10	5	4byte	RW	Big
9	Algorithm control	0×2b0	0bit: Delect defective pixel switch 1bit: Dark field correction switch 2bit: Denoise switch	7	4byte	RW	Big
10	Defective pixel	0×320			4byte	W	Big

	reload						
11	TEC Temperature Setting	0×330	T(°C)=data/10, complement-on-two	0	4byte	RW	Big
12	TEC temperature reading	0×340	T(°C)=data/10, complement-on-two		4byte	R	Big
13	TEC switch control	0×350	1 is on and 0 is off	1	4byte	RW	Big
14	Fan control	0×360	1 is on and 0 is off	1	4byte	RW	Big
15	Automatic dark field switch	0×370	1 is on and 0 is off	1	4byte	RW	Big
16	Manual dark field selection	0×380	1~15	1	4byte	RW	Big
17	Auto exposure switch	0×390	1 is on and 0 is off(Not supported yet)	0	4byte	RW	Big
18	tri_mode	0×400	0-Normal Mode 1- Trigger Mode	0	4byte	RW	Big
19	soft_always_en	0×410	0-soft disable 1-soft always enable	0	4byte	RW	Big
20	tri_source_i	0×420	trigger source: 0-Opt_in 1-GPIO_0 2-GPIO_1 3- counter 4-PWM 5-software	0	4byte	RW	Big
21	tri_activation_i	0×430	0- rising edge; 1- falling edge; 2- level high; 3- level low	0	4byte	RW	Big
22	burst_counter_i	0×440	continuous acquisition 0-65535	0	4byte	RW	Big
23	counter_source_i	0×450	0-Opt_in 1-GPIO_0 2-GPIO_0	0	4byte	RW	Big
24	counter_value_i	0×460	Frequency division coefficient	0	4byte	RW	Big
25	pwm_source_i	0×470	0-Opt_in 1-GPIO_0 2-GPIO_1	0	4byte	RW	Big
26	IO_link	0×480	0bit: GPIO_0: 0-input,1-output 1bit: GPIO_1: 0-input,1-output	0	4byte	RW	Big
27	soft_start	0×490	software trigger	0	4byte	W	Big
28	tri_delay_0_i	0×4a0	when the Opt_in trigger assert, the start of exposure will delay 0-32xffff ffff(cycle)	0	4byte	RW	Big
29	tri_delay_1_i	0×4b0	when the GPIO_0 trigger assert, the start of exposure will delay 0-32xffff ffff(cycle)	0	4byte	RW	Big
30	tri_delay_2_i	0×4c0	when the GPIO_1 trigger assert, the start of exposure will delay 0-32xffff ffff(cycle)	0	4byte	RW	Big
31	tri_delay_s_i	0×4d0	when the software trigger assert, the start of exposure will delay 0-32xffff ffff(cycle)	0	4byte	RW	Big
32	output_mode_0_i	0×4e0	Opt_out output mode: 0-Frame Trigger Wait 1-Exposure Active 2-Strobe 3-User output	0	4byte	RW	Big
33	output_mode_1_i	0×4f0	GPIO_0 Output mode: 0-Frame Trigger Wait 1-Exposure Active 2-Strobe	0	4byte	RW	Big

3-User output							
34	output_mode_2_i	0×500	GPIO_1 output mode: 0- Frame Trigger Wait 1-Exposure Active 2-Strobe 3-User output	0	4byte	RW	Big
35	duration_time_i	0×510	Strobe duration time:effective time 0- 32×ffff ffff(cycle)	0	4byte	RW	Big
36	pre_delay_i	0×520	advance the exposure time 0-32×ffff ffff(cycle)	0	4byte	RW	Big
37	output_delay_i	0×530	later than exposure time 0- 32×ffff ffff(cycle)	0	4byte	RW	Big
38	user_value	0×540	Opt_out--user value	0	4byte	RW	Big
39	tri_prohibited_i	0×550	next trigger rising prohibited time 4100~32×ffff ffff(cycle)	4100	4byte	RW	Big
40	counter_reset	0×560	When counter_reset assert, the counter of trigger will be reseted	0	4byte	W	Big
41	debounce_0	0×570	debounce time: 0-20000us	0	4byte	RW	Big
42	debounce_1	0×580	debounce time: 0-20000us	0	4byte	RW	Big
43	debounce_2	0×590	debounce time: 0-20000us	0	4byte	RW	Big
44	line_inverter	0×5a0	1-enable	3'b111	4byte	RW	Big
45	output_counter_i	0×5b0		1	4byte	RW	Big
46	pause	0×5c0		0	4byte	RW	Big
47	Frame count cleared to zero	0×5d0	0bit: frame_clr 1bit: tri_clr 2bit: time_clr 3bit: all_clr	0	4byte	W	Big
48	Frame count display switch	0×5e0		0	4byte	RW	Big
49	Dark field threshold control	0×5f0	0-16384	16383	4byte	W	Big
50	Version	0×3a0	MCU Version + maximum frame rate + Firmware version + Firmware date		16byte	R	Big
51	Read mode switching	0×1f0	0: IWR(Integrate while reading) 1: ITR(Integrate then read)	1	4byte	RW	Big

12.7.4 Camera instruction example

Set the exposure time command:

```
01 00 B7 C8 91 E0 00 00 40 01 08 02 00 0C 00 28 00 00 00 00 20 00 02 00 00 00 03 E8
```

Set exposure time: 1000 = 0×03E8, seunqe ID is 0×28, expressed as instruction 0×28 sent, which can always be 0.

Double-byte CRC redundancy check:

```
B7 C8 = !(00 00 + 40 01 + 08 02 + 00 0C + 00 28)
```

```
91 E0 = !(00 00 + 40 01 + 08 02 + 00 0C + 00 28 + 00 00 + 00 00 + 20 00 + 02 00 + 00 00 + 03 E8)
```

Read the exposure time command:

```
01 00 B7 E2 95 DE 00 00 40 01 08 00 00 0C 00 10 00 00 00 00 20 00 02 00 00 00 00 04
```

Here the seunqe ID is 0×10

Read exposure time Return content:

```
01 00 F7 EA F7 22 00 00 00 00 08 01 00 04 00 10 00 00 00 C8
```

This returns 200us.

12.8 CL SDK & CLView application

12.8.1 CL SDK

The camera control supports two modes: 1) Controlled through private SDK development kit; 2) Controlled by GenICam interface.

12.8.2 CLView application

CLView software can achieve complete control of the camera, and open source to customers to use, while providing technical support.

Description of the main functions of CLView software:

Serial port control;

Exposure time control;

Gain mode control;

ROI control;

Frame rate control;

Trigger mode control;

Dark field correction control;

TEC and Fan control;

Refrigeration temperature control;

Real-time frame rate display;

Real-time temperature monitoring;

Save picture;

Video;

Update online;

Accept customer OEM functions customized.



Figure 12-24 CLView Software interface

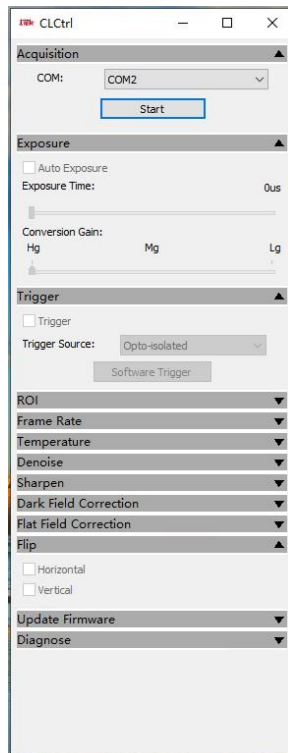

12.8.3 CLCtrl software

The camera can capture and display images through the software CameraLink capture card, and use the CLCtrl software to control. Start the CLCtrl software first, and then start the acquisition card software after obtaining the control of the serial port.



13 EHD imaging GmbH®-- Contact Information

For the latest EHDview, please visit our website (www.ehd.de) and download the newest version.

	<table border="1"> <tr><td data-bbox="337 436 1472 478">EHD imaging GmbH</td></tr> <tr><td data-bbox="337 478 1472 520">Zum Rennplatz 15</td></tr> <tr><td data-bbox="337 520 1472 562">49401 Damme</td></tr> <tr><td data-bbox="337 562 1472 596">Germany</td></tr> </table>	EHD imaging GmbH	Zum Rennplatz 15	49401 Damme	Germany
EHD imaging GmbH					
Zum Rennplatz 15					
49401 Damme					
Germany					
	+49-5491-2090				
	info@ehdimaging.de				

